

General safety and accident prevention regulations

Requirements

- Responsibilities for the various activities on the machines must clearly be defined and maintained. There must not be any confusion regarding responsibilities, otherwise the safety of the assembly personnel would be put at risk.
- Before you start working, familiarize yourself with all the fittings and actuation elements and their functions.
- Wear close-fitting clothes when operating the machine. Wear sturdy footwear and prescribed protective equipment.
- Support and secure the machine carefully during assembly.
- Protective equipment must be properly attached and swung into its protective position.

Work material

- For all kind of work on the machine, only use appropriate tools and implements in perfect conditions.
- You must only use parts (accessories, lubricants, etc.) which comply with at least the manufacturer's specifications; you must use them in accordance with the instructions.
- A part conforms to the requirements only if it is an original part or if it is expressly approved by the manufacturer.

Hazard areas

- Do not leave the engine running in enclosed spaces.
- Actuation elements (ropes, chains and rod assemblies) of remotely controlled equipment must be fitted in such a way that they cannot cause unintended movement in any transport or work position.
- All tightening torques specified in these assembly instructions must be observed for screwed connections.
- All remote-powered and all other movable parts (e.g. hydraulically actuated parts) have crush or shear points.
- Pay close attention to the markings on reversible connections and be aware of the risk of installing a part the wrong way round.
- Always disconnect the power supply before working on the electrical system.
- When carrying out electric welding on the machine, always disconnect electric cables from the alternator and battery.
- Particular care must be taken in dealing with energy accumulators such as springs and hydraulic or compressed-air assemblies.

Environment

- Dispose of oils, grease, and filters in accordance with regulations.

Direction information

Direction information (right, left, front, rear) is given in relation to the direction of travel. Rotary direction is defined as follows:

- Rotary direction right = clockwise.
- Rotary direction left = counterclockwise.
- Rotation about a vertical axis, viewed from top to bottom.
- Rotation about a horizontal axis, viewed at right angle to the direction of travel, from left to right.
- The rotation of bolts and nuts, etc. is always viewed from the operating side.

Screwed connections



Observe the torque specifications

Securely tighten screws, nuts and bolts to the specified torques. Incorrectly tightened screwed connections can loosen or become jammed. This could result in machine damage or injury.

Use original parts

Machine components have special properties that are essential for the stability and correct operation of the machine. Only spare parts and accessories supplied by the manufacturer have been tested and approved. Other products may adversely affect the correct operation of the machine and safety. The use of non-OEM replacement parts renders the manufacturer's guarantee null and void and frees the manufacturer from all liability.

On this machine, bolts and nuts with a minimum quality of "8.8" (which can be seen on the bolt head) are used. If no bolt tightening torques are indicated in the drawing, the screwed connections are to be tightened according the table. Bolt tightening torques that differ from those provided in drawings or specified in the tables are indicated in the particular fitting steps.

Tightening screws

All bolts must be retightened:

- After the first five hours of operation.
- According to the frequency of use.
- At least once a season.

Screw tightening torques



Use the correct screw and bolt tightening torques

Securely tighten screws, nuts and bolts to the specified torques. Otherwise, damages to the machine and serious or fatal injuries may be caused as a result.

Note the strength class specification for screws, nuts and bolts. Refer to the table for the corresponding tightening torque. Securely tighten screws, nuts and bolts to the specified values, provided that no other value is specified. The torque specifications refer to a dry coefficient of friction (0.12).

Bolt size	8.8		10.9		12.9	
	N.m	ft.lbf	N.m	ft.lbf	N.m	ft.lbf
M3	1,41	1,04	2,07	1,53	2,43	1,79
M4	3,22	2,38	4,74	3,50	5,5	4,06
M5	6,4	4,72	9,4	6,94	11	8,12
M6	11,1	8,19	16,3	12,03	19,1	14,10
M8	27	20	39	29	46	34
M10	53	39	78	58	92	68
M12	92	68	136	100	159	117
M14	148	109	218	161	255	188
M16	232	171	341	252	399	294
M18	330	244	469	346	549	405
M20	471	348	667	492	781	576
M22	648	478	920	679	1077	795
M24	809	597	1148	847	1343	991
M27	1201	886	1706	1259	1997	1474
M30	1628	1201	2311	1706	2704	1996
M33	2216	1635	3148	2323	3684	2719
M36	2840	2096	4036	2979	4723	3486
M39	3697	2728	5255	3878	6150	4539



Tighten safety bolts and lock nuts to a 10% higher value.

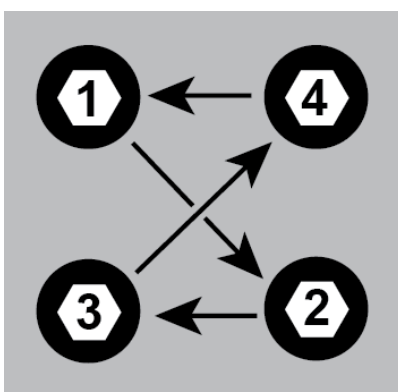

On a level surface, tighten the bolts evenly, alternating between the bolts. This ensures that the connection is distortion-free. Otherwise, damage to the machine may be caused as a result.

Target group for these assembly instructions



For your safety

You must familiarize yourself with the content of these assembly instructions before assembling or operating the machine. In this way, you will achieve optimum work results and operational safety.

The assembly instructions form an integral part of the machine and must always be kept to hand. This will ensure that:

- accidents are avoided,
- warranty conditions are met.

For the employer

Untrained or unauthorized individuals are not permitted to assemble the machinery.

For the employee

If the assembly instructions are unclear or ambiguous, immediately stop working and assembling. Consult your supervisor or your employer. In such cases, your supervisor or employer must consult the service departments of the manufacturer.

These instructions are intended for authorized dealers, workshop and agents qualified in the field of agricultural mechanical engineering and who have completed the appropriate training at Kverneland Service.

Symbols used

The following symbols and terms have been used:

- A bullet point accompanies each item in a list.
- ▶ A triangle indicates operating functions which must be performed.

We have also used pictograms to help you find instructions more quickly:



The “Information” pictogram indicates tips and additional information.



The “Examples” pictogram indicates examples that assist understanding of the instructions.



The warning triangle indicates warning information. Failure to observe these safety instructions can result in:

- Moderate to serious injury.
- Fatal injury.

The warning information in this document is specifically associated with individual operations and instructions. It is important to observe the warning information before carrying out these operations.



The information triangle indicates important information. Failure to observe these safety instructions can result in:

- Serious faults in the correct operation of the machine.
- Damages to the machine.



The spanner indicates tips for assembly or adjustment work.



This arrow shows the direction of travel.



- ▶ Switch on the tractor engine.



- ▶ Shut off the engine,
- ▶ set the parking brake,
- ▶ remove the ignition key,
- ▶ secure the tractor against rolling away.



The bag contains small parts required for the instructions described. Small parts may already be fitted on the machine.





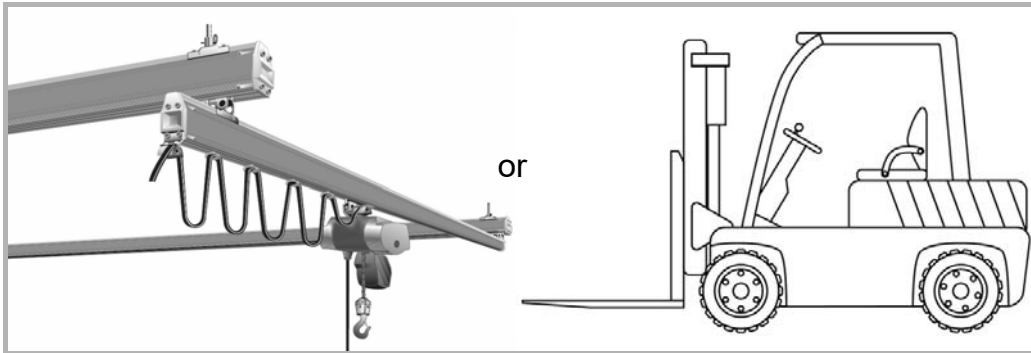

Before assembly

Required tools



Assembly duration

Around 3 hours for 3M00 and 3M50 (9'10" and 11'6") machines with bridge crane.

Image	Reference	Description	Qty *
	RF00910	U-BOLT M12 FOR PIPE 90X90	2
	KG01067761	LOCK NUT M12 8	4
	RF04030	U-BOLT M16 FOR PIPE 90X90	4
	KG01067961	LOCK NUT M16 8	8
	A135369562	U BOLT M20 L 136 BEAM 90	4
	KG01069261	LOCK NUT M20 10	8

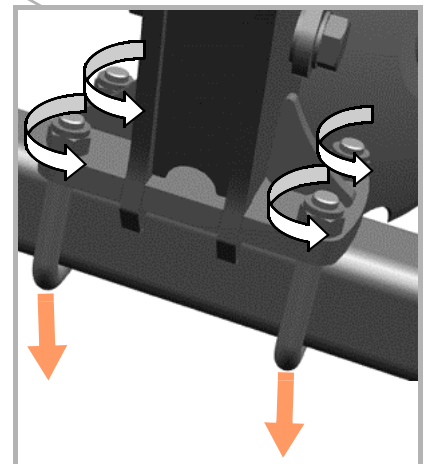
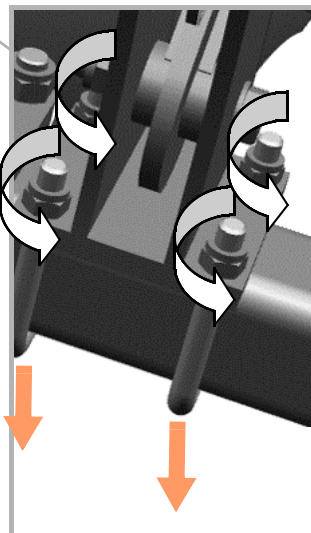
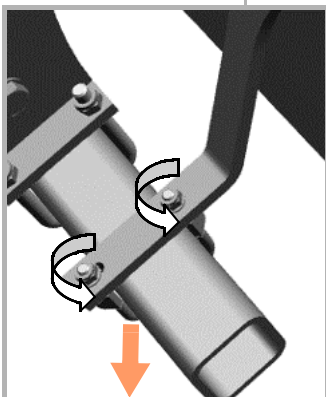
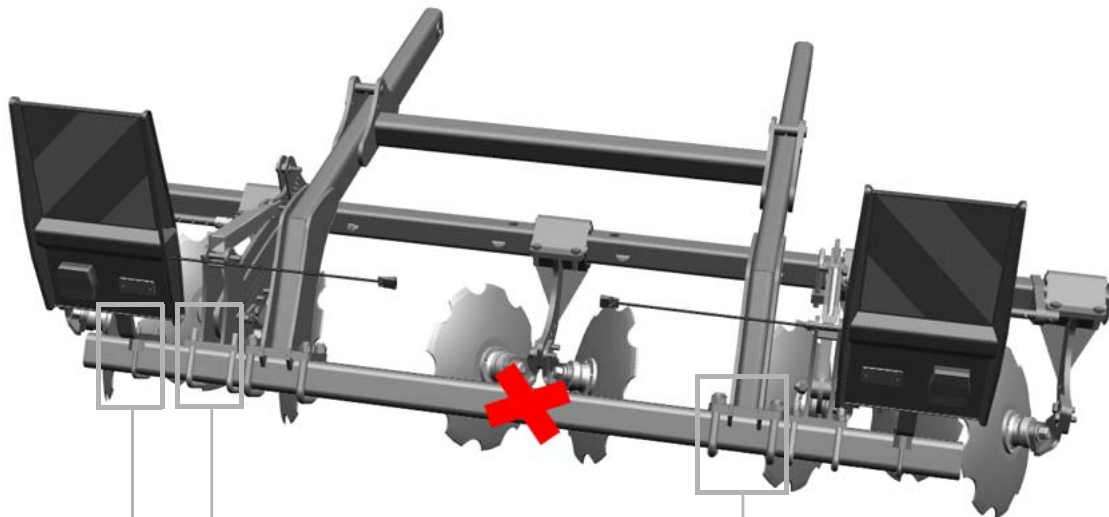





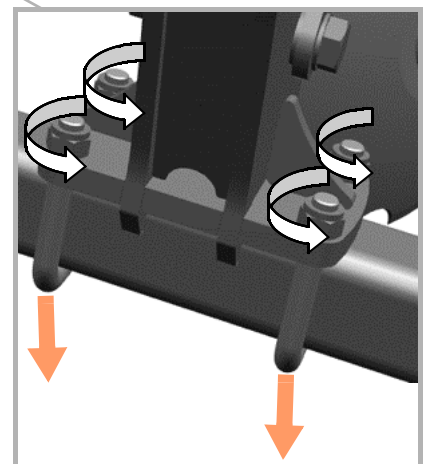
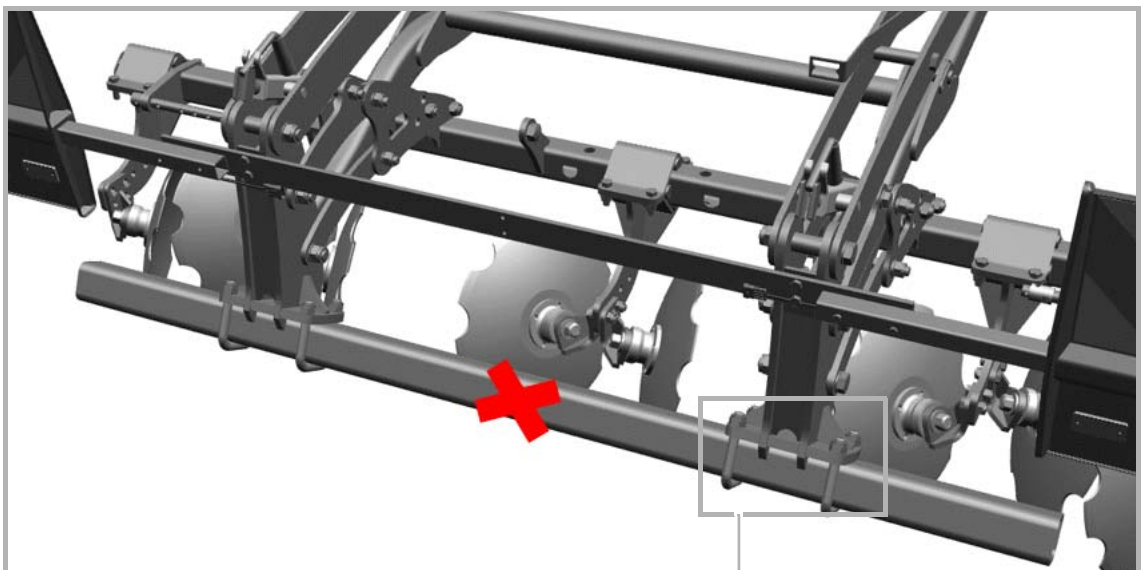

Image	Reference	Description	Qty *
	RF00910	U-BOLT M12 FOR PIPE 90X90	2
	KG01067761	LOCK NUT M12 8	4
	RF04030	U-BOLT M16 FOR PIPE 90X90	4
	KG01067961	LOCK NUT M16 8	8
	A135369562	U BOLT M20 L 136 BEAM 90	4
	KG01069261	LOCK NUT M20 10	8





Assembly tines

Necessary tools



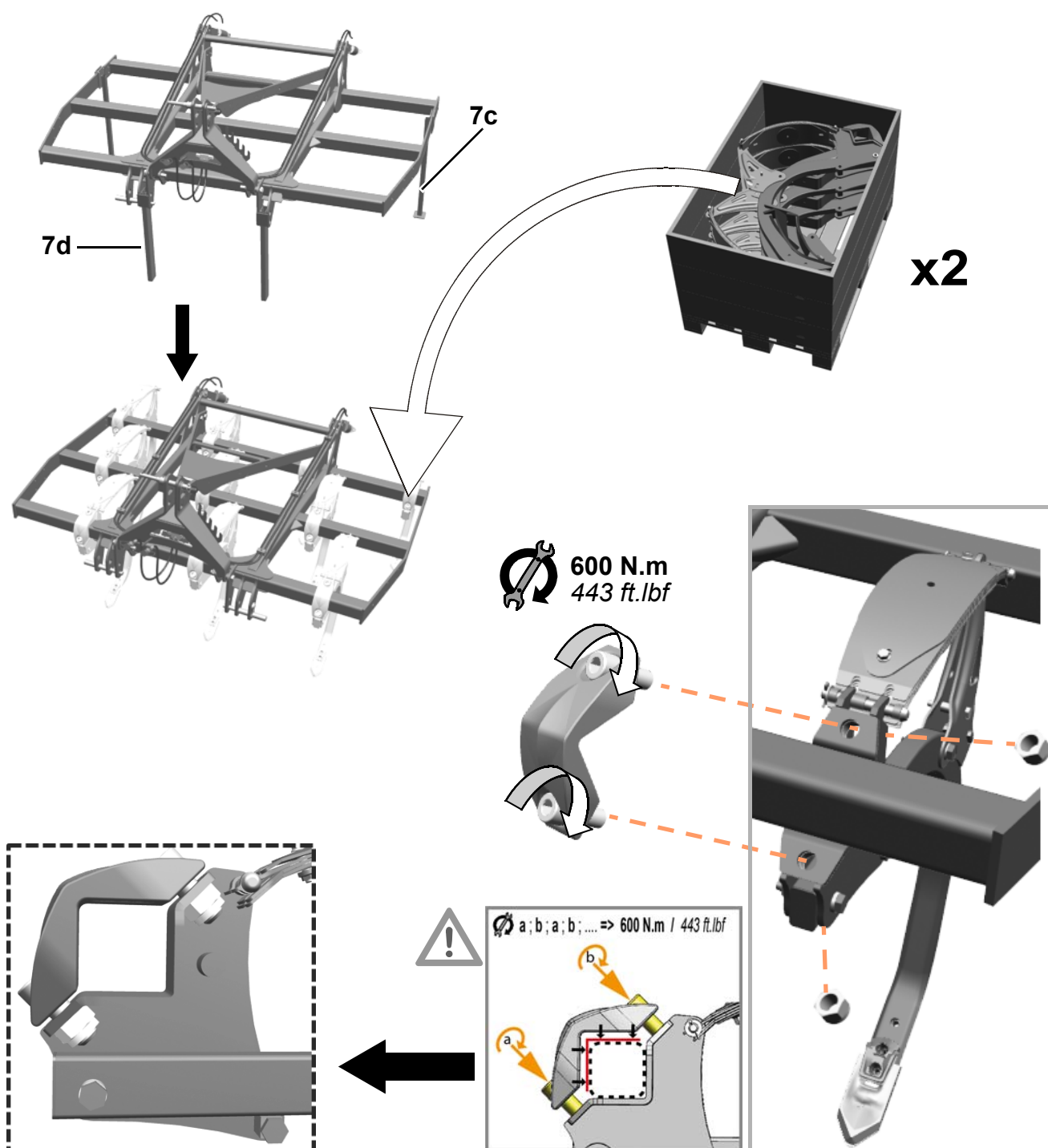

Make sur you have a lifting tool at your disposal.

Triflex 700

Image	Reference	Description	Qty*
	A135422161	CHEESE HEAD SCREW M27X65	2 per tine
	KG01069461	LOCK NUT M27 10	



Shear Bolt tine

Image	Reference	Description	Qty*
	KG00358261	HEX. BOLT M12X90 8.8	1 <i>per tine</i>
	KG01067761	LOCK NUT M12 8	
	KK032795	HEX BOLT M16X95	
	KK016025	LOCK NUT M16	
	A135422262	CONE	2 <i>per tine</i>

Assembly tines

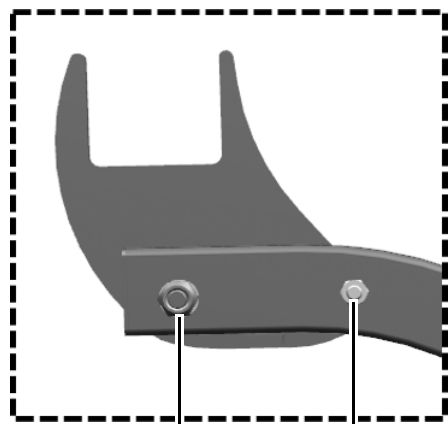
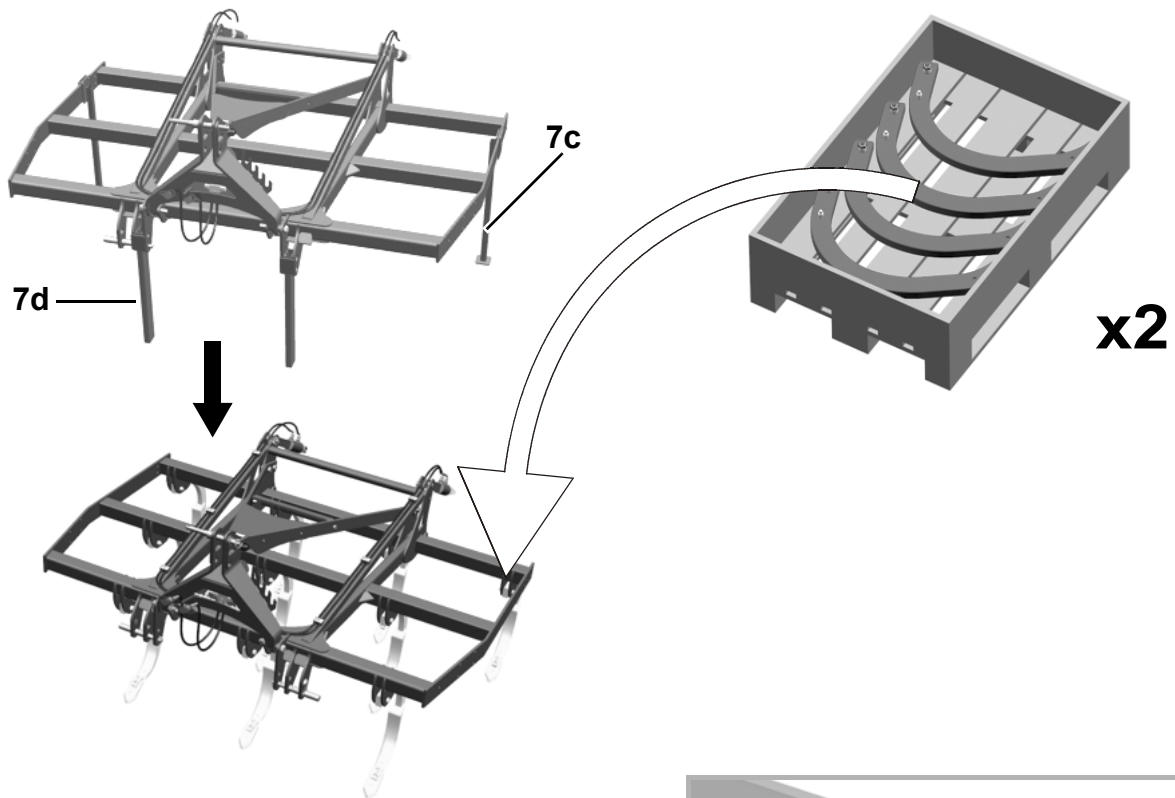





600 N.m
443 ft.lbf

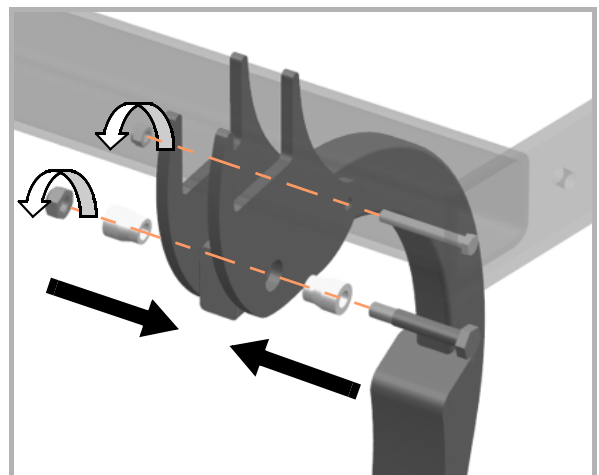

In contact

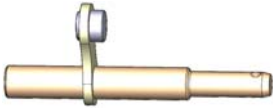

Container kit dismantling

Image	Reference	Description	Qty
	KG00358261	HEX. BOLT M12X90 8.8	8
	KG01067761	LOCK NUT M12 8	8
	A1354896	Lower pin with stop	2
	RF0015	Clip pin	2

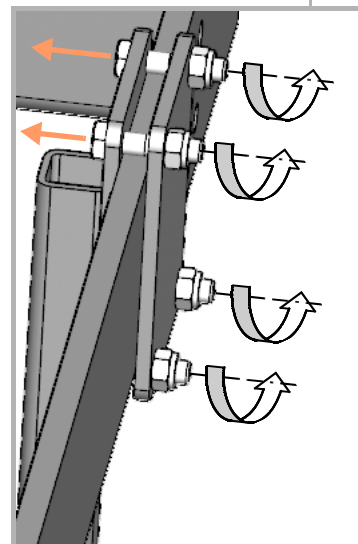
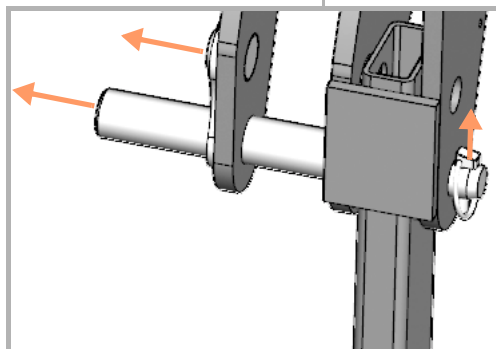
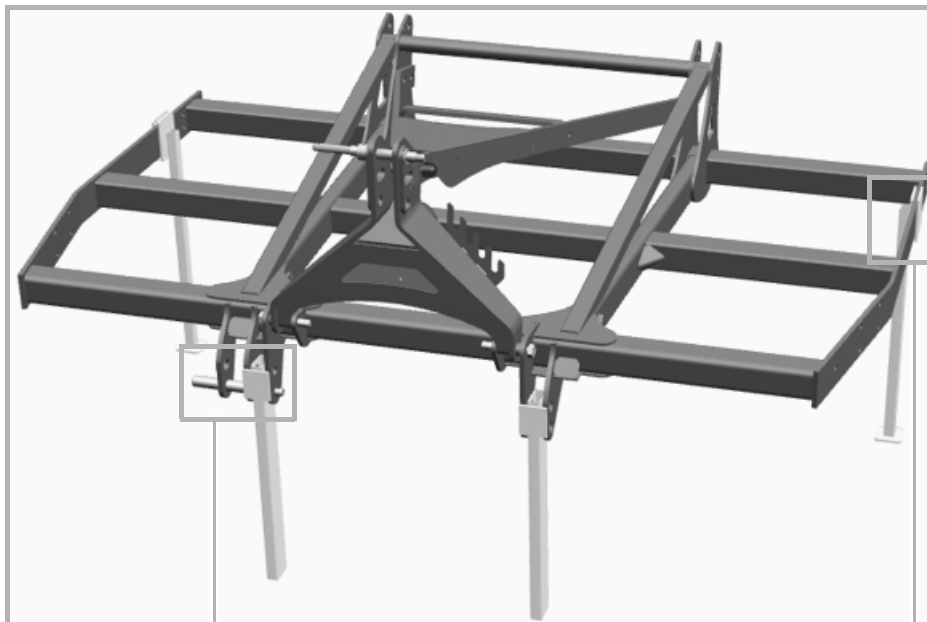

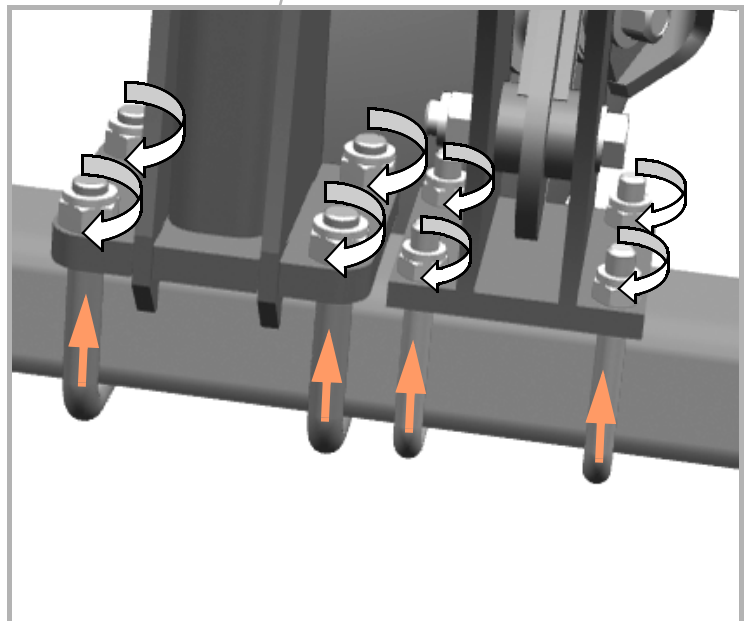
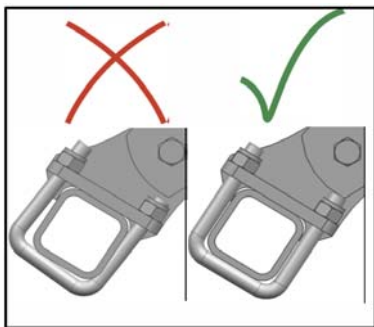
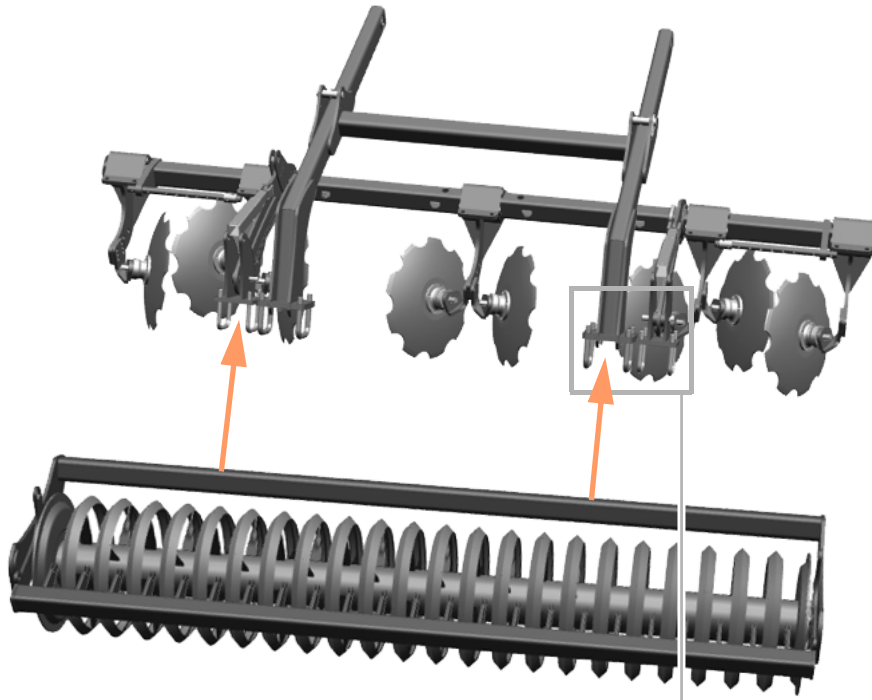

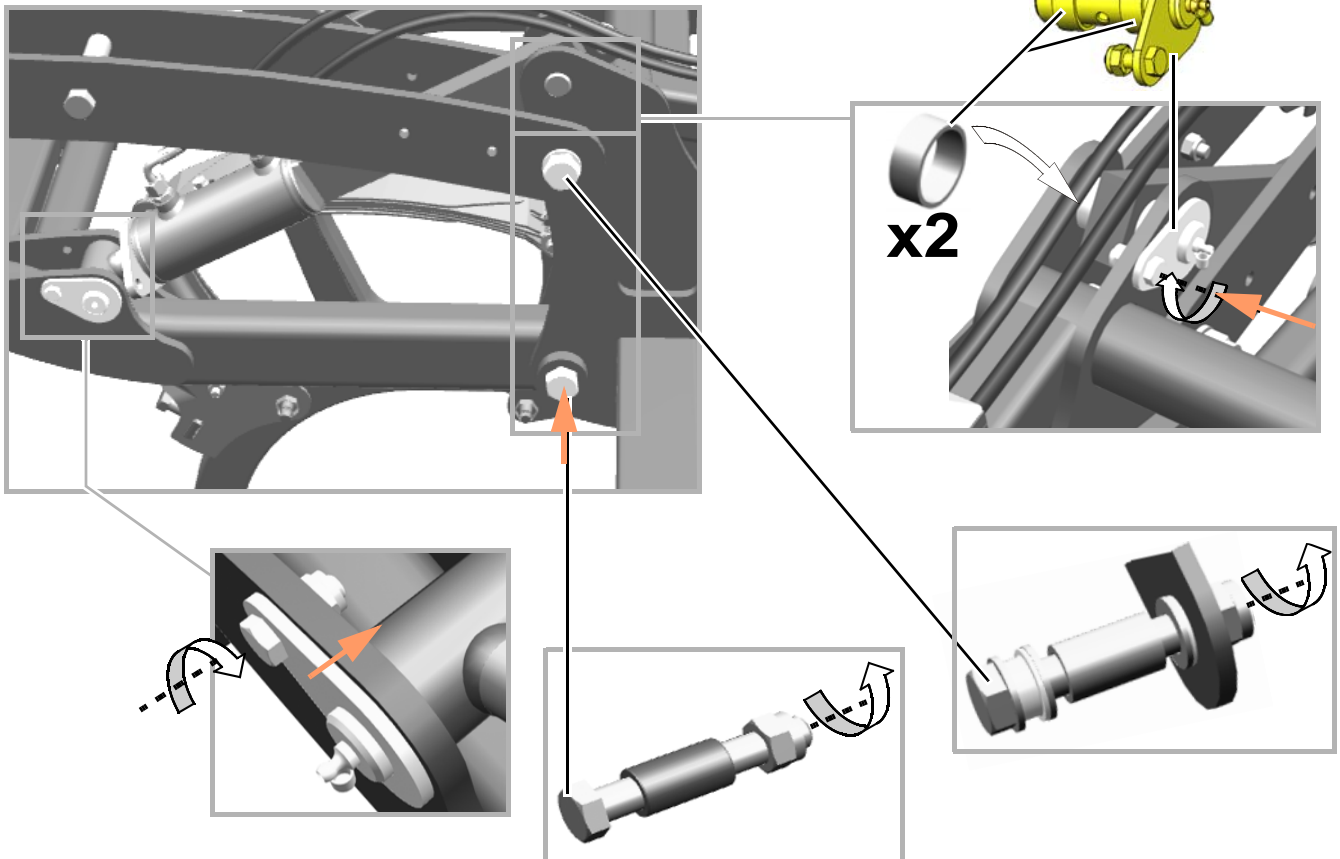
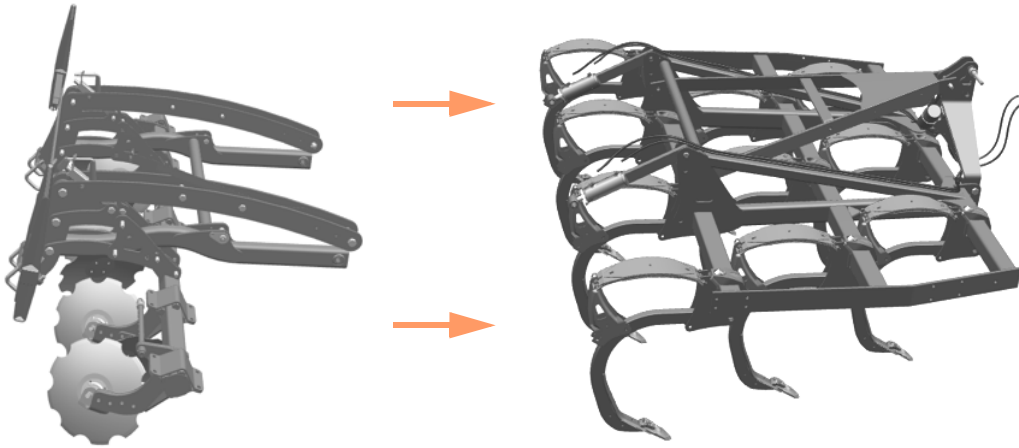

Assembly rear accessories

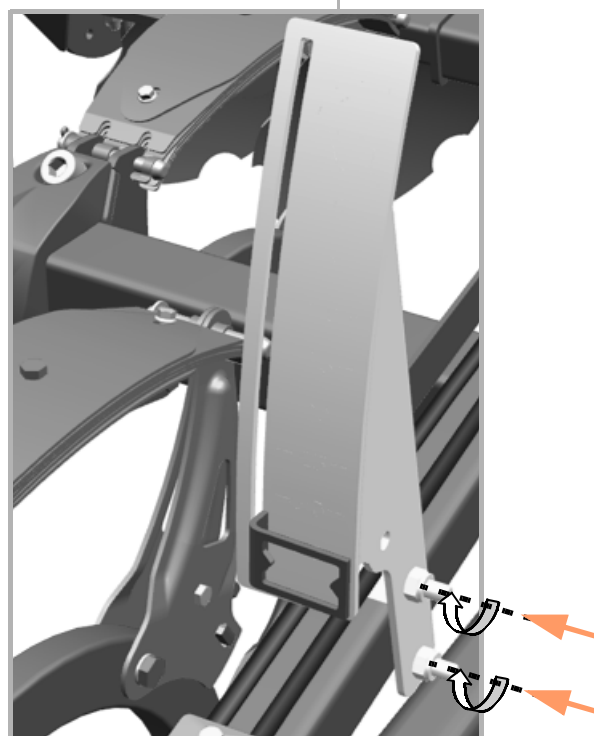
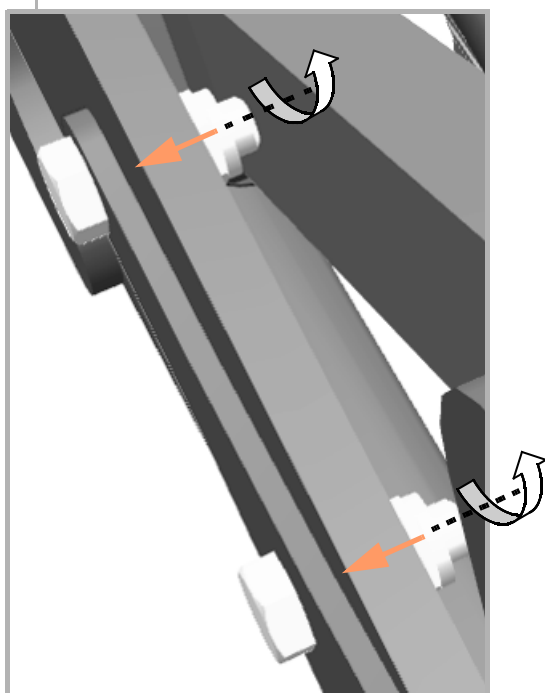
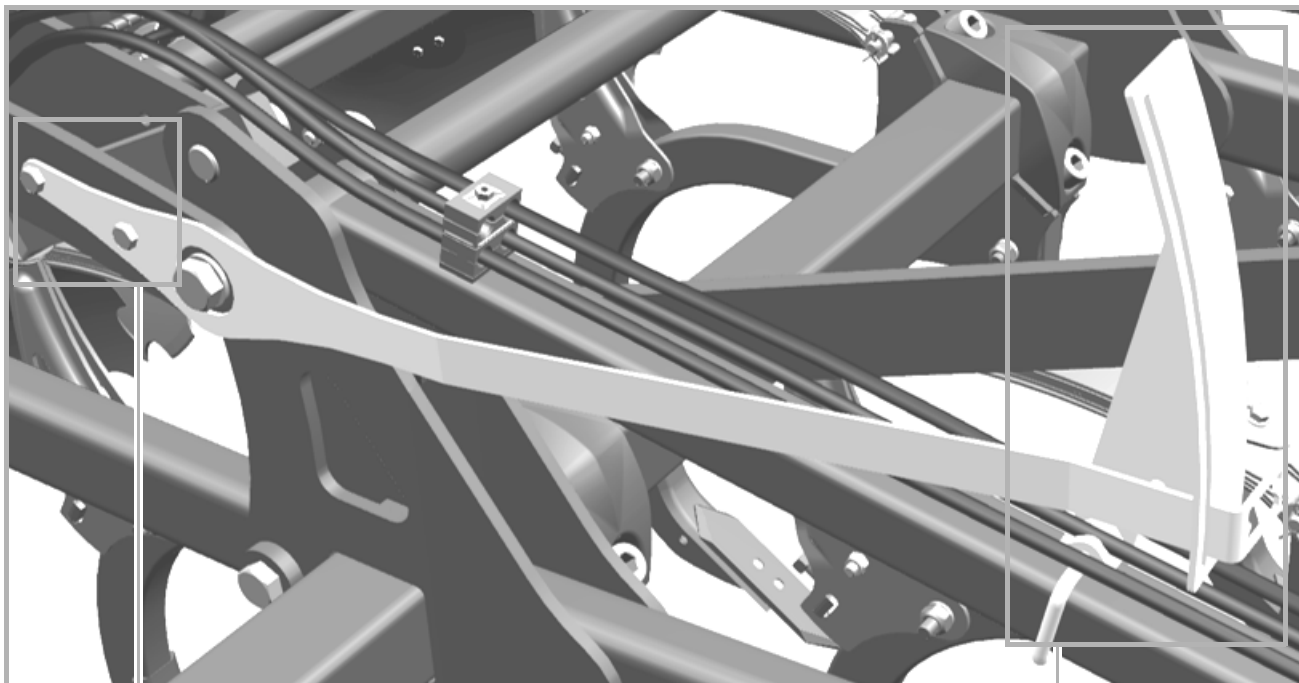

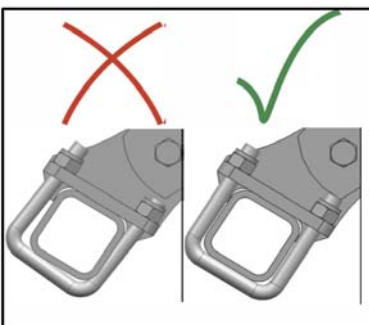
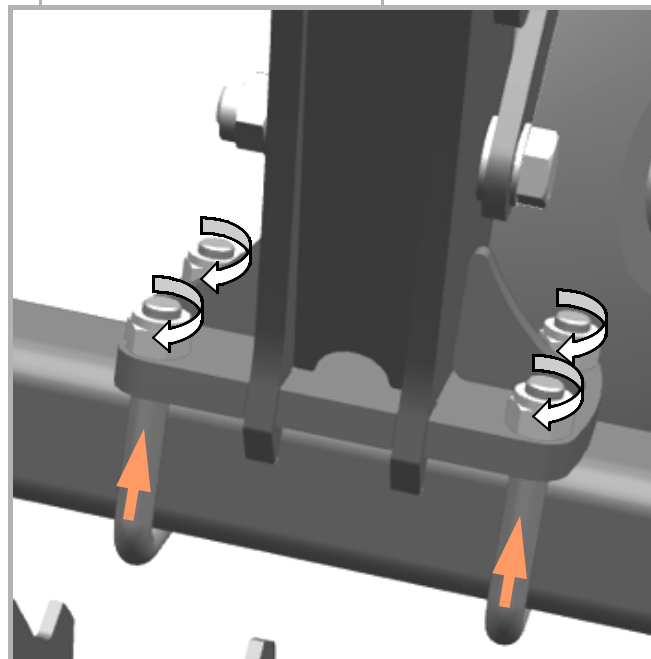
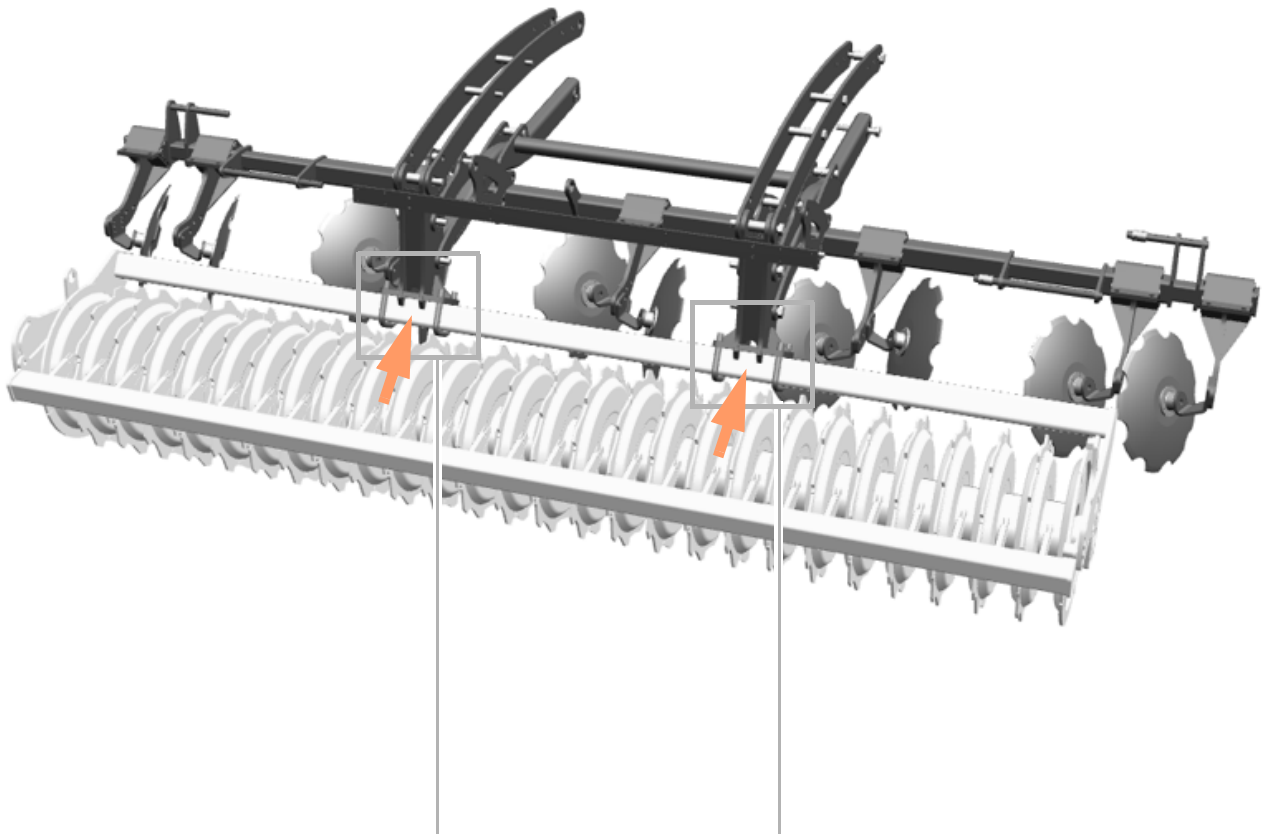



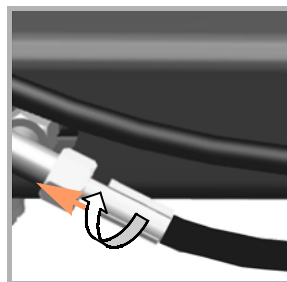
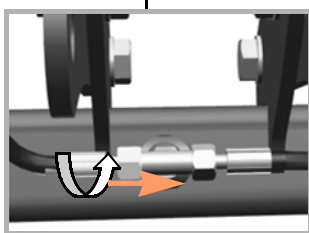
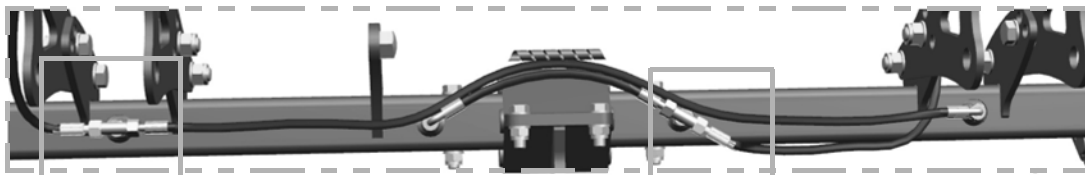
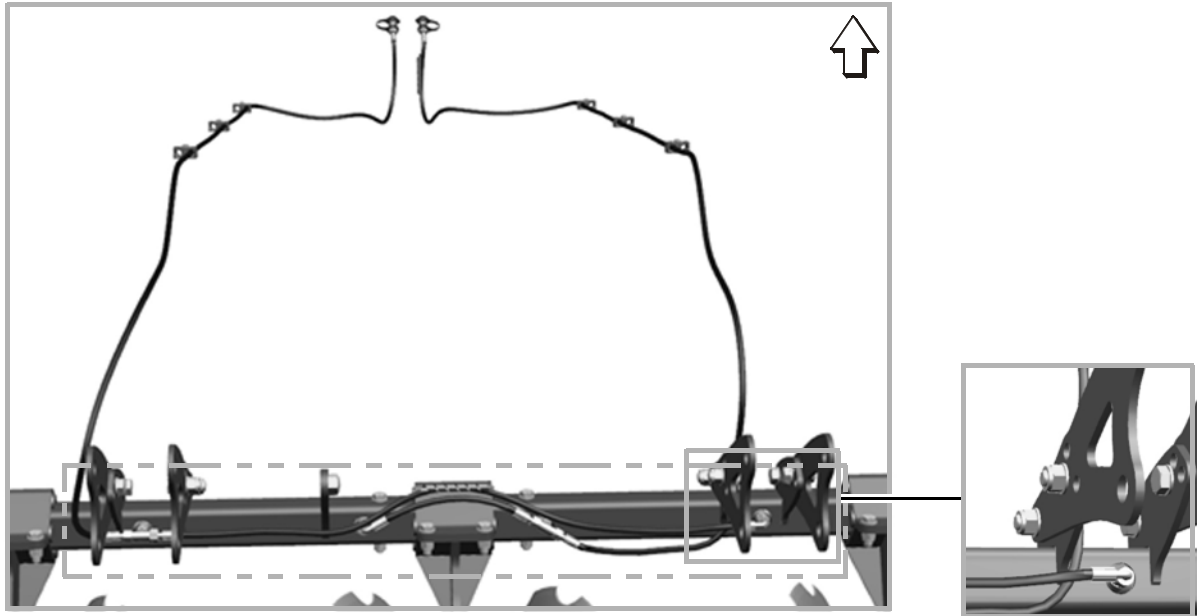



Enduro Pro



Shares on tines assembly

KNOCK-ON

Parts





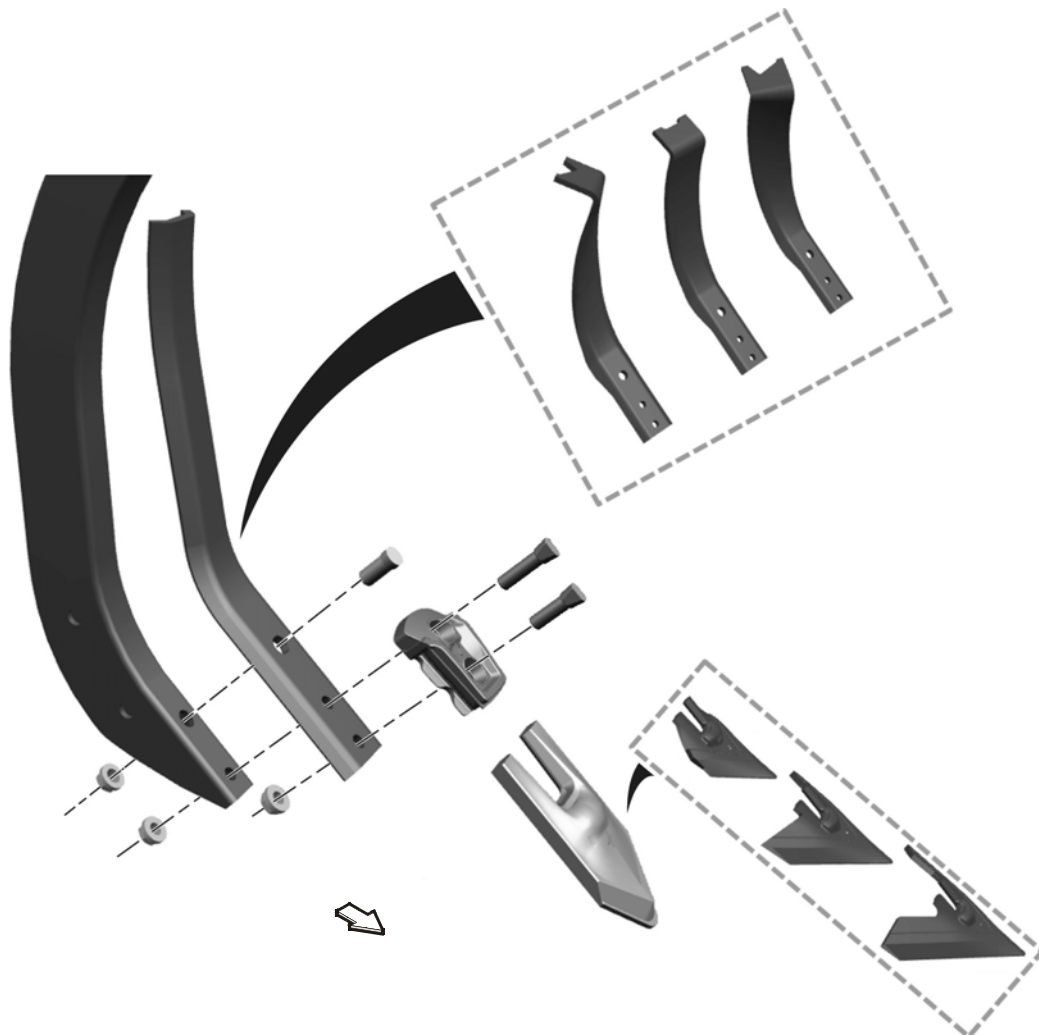

Image	Reference	Description	Qty
	A135422362	CONE SCREW M14X34	1
	KK016015	FLANGE NUT M14	1
	A135469562	CONE SCREW M12X49	1
	KK016038	FLANGE NUT M12	1
	A152298000	CONE SCREW M12X43	1
	KK016038	FLANGE NUT M12	1

Assembly



Plough point

Parts

Image	Reference	Description	Qty
	A135422362	CONE SCREW M14X34	1
	KK016015	FLANGE NUT M14	1
	KK013244	SCREW M12X45	1
	KK016038	FLANGE NUT M12	1
	KK013228R	CS BOLT M12X34	1
	KK016038	FLANGE NUT M12	1

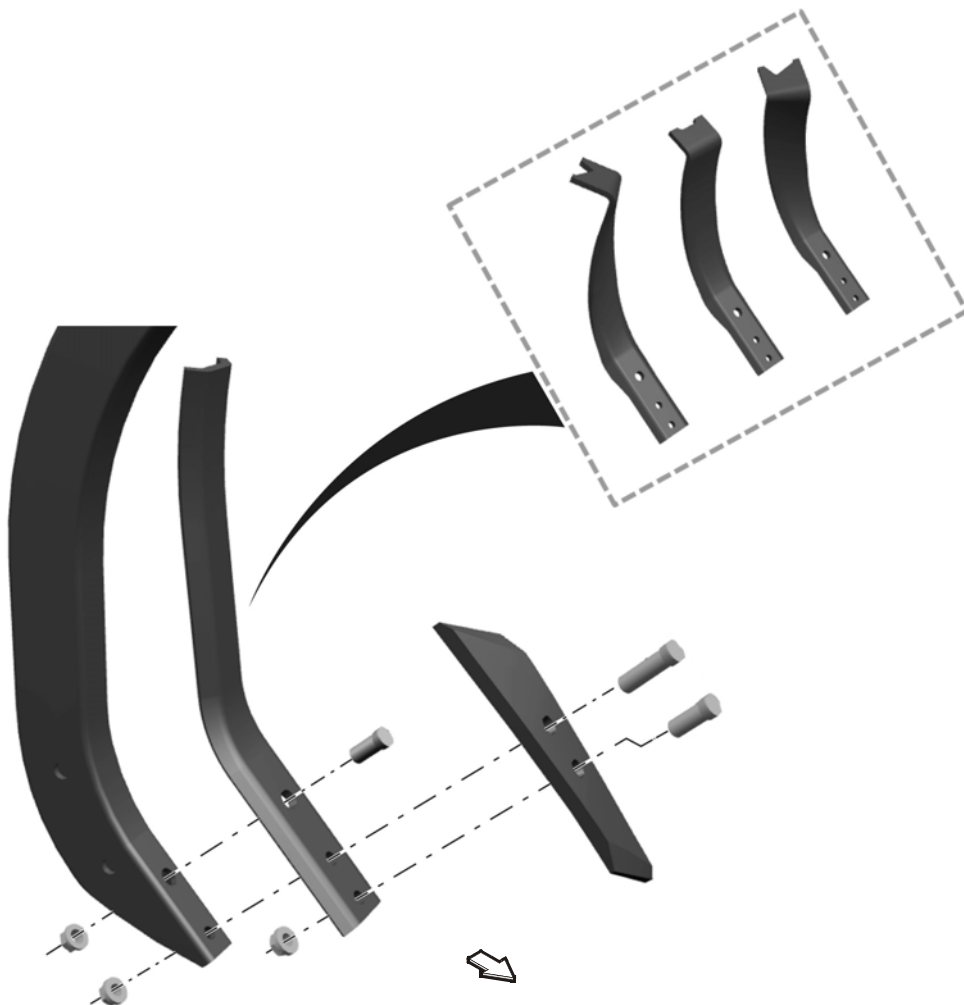

Assembly



Shares on tines assembly

Wings 320

Parts





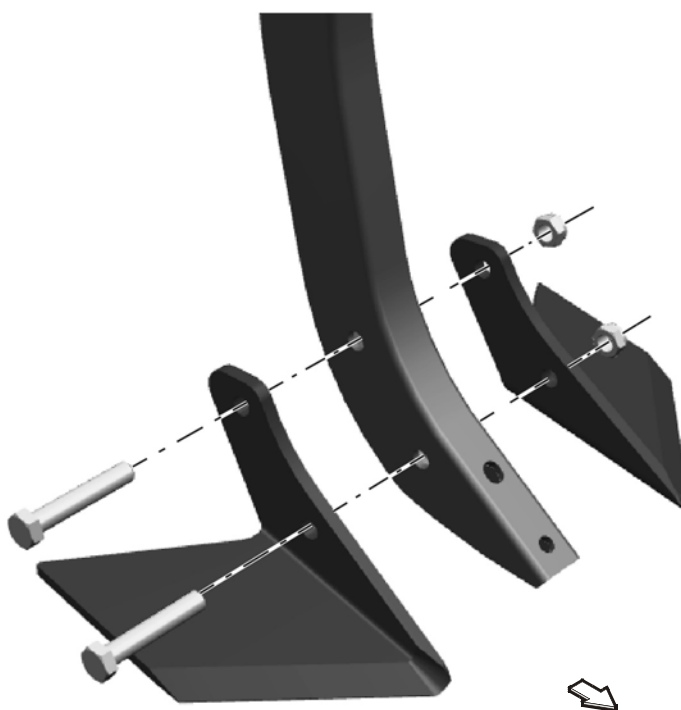

Image	Reference	Description	Qty
	A135427761	HEX. BOLT M14X80	1
	KG01073461	LOCK NUT M14 10	1

Assembly



Carbide point

Parts

Image	Reference	Description	Qty
	A135422362	CONE SCREW M14X34	1
	KK016015	FLANGE NUT M14	1
	A135469562	CONE SCREW M12X49	1
	KK016038	FLANGE NUT M12	1
	A152298000	CONE SCREW M12X43	1
	KK016038	FLANGE NUT M12	1

Assembly

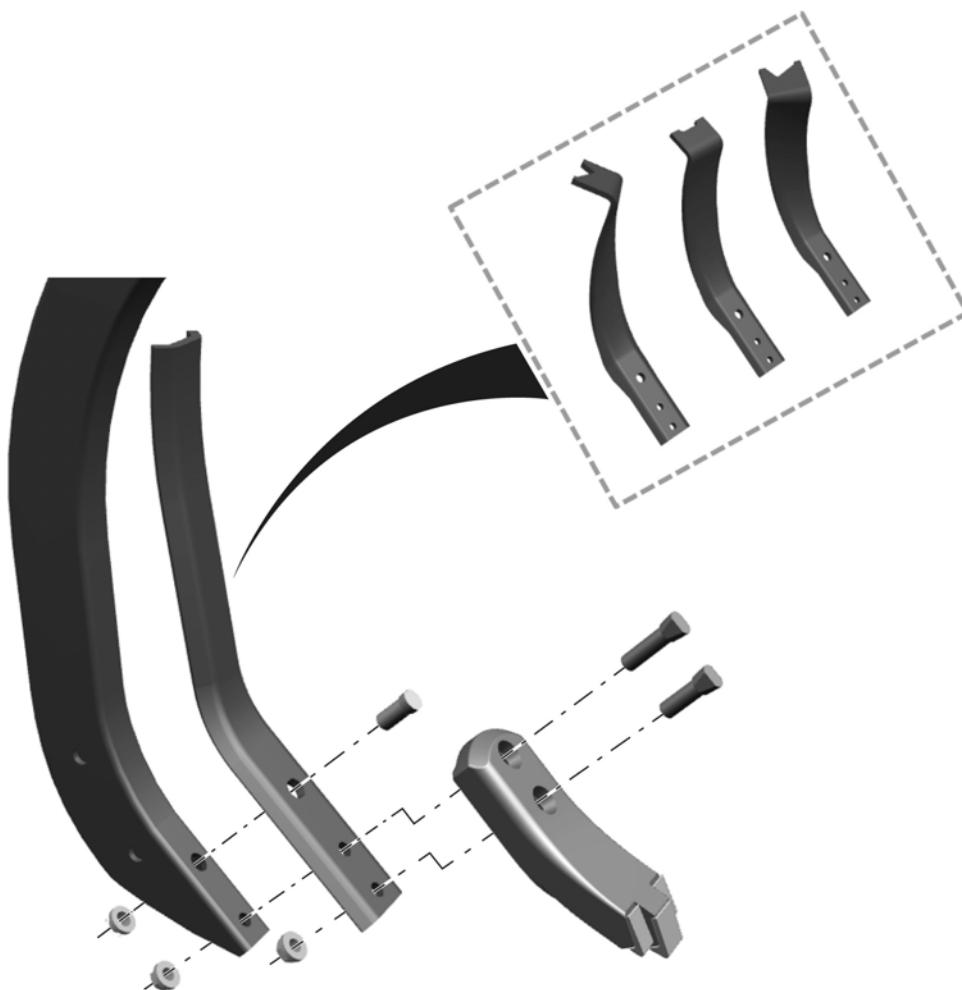

Shares on tines assembly

Tines distribution

3M machines

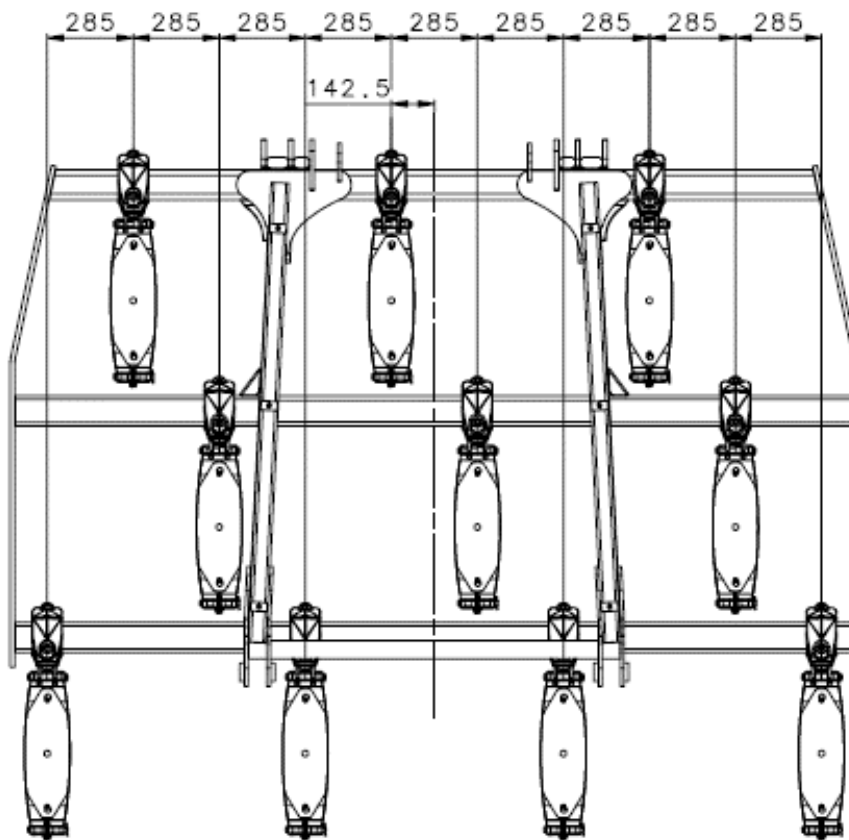

3M50 machines

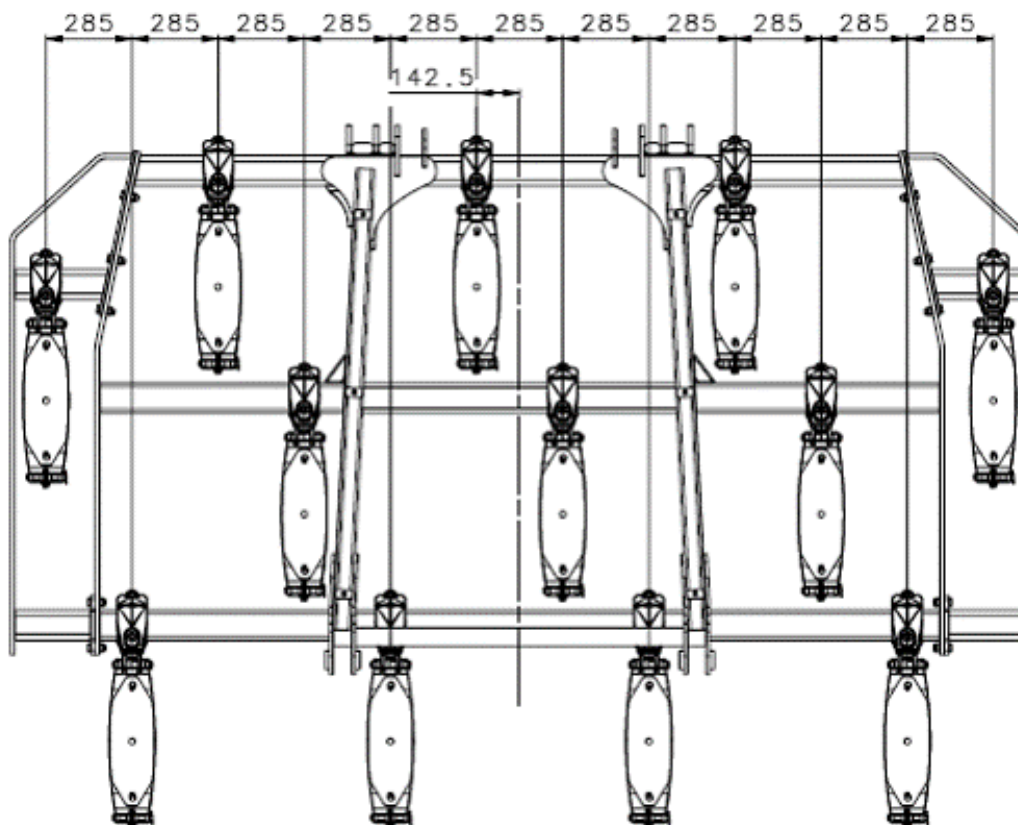

Deflectors distribution

- Right side: **straight points:**



- Left side: **left points:**

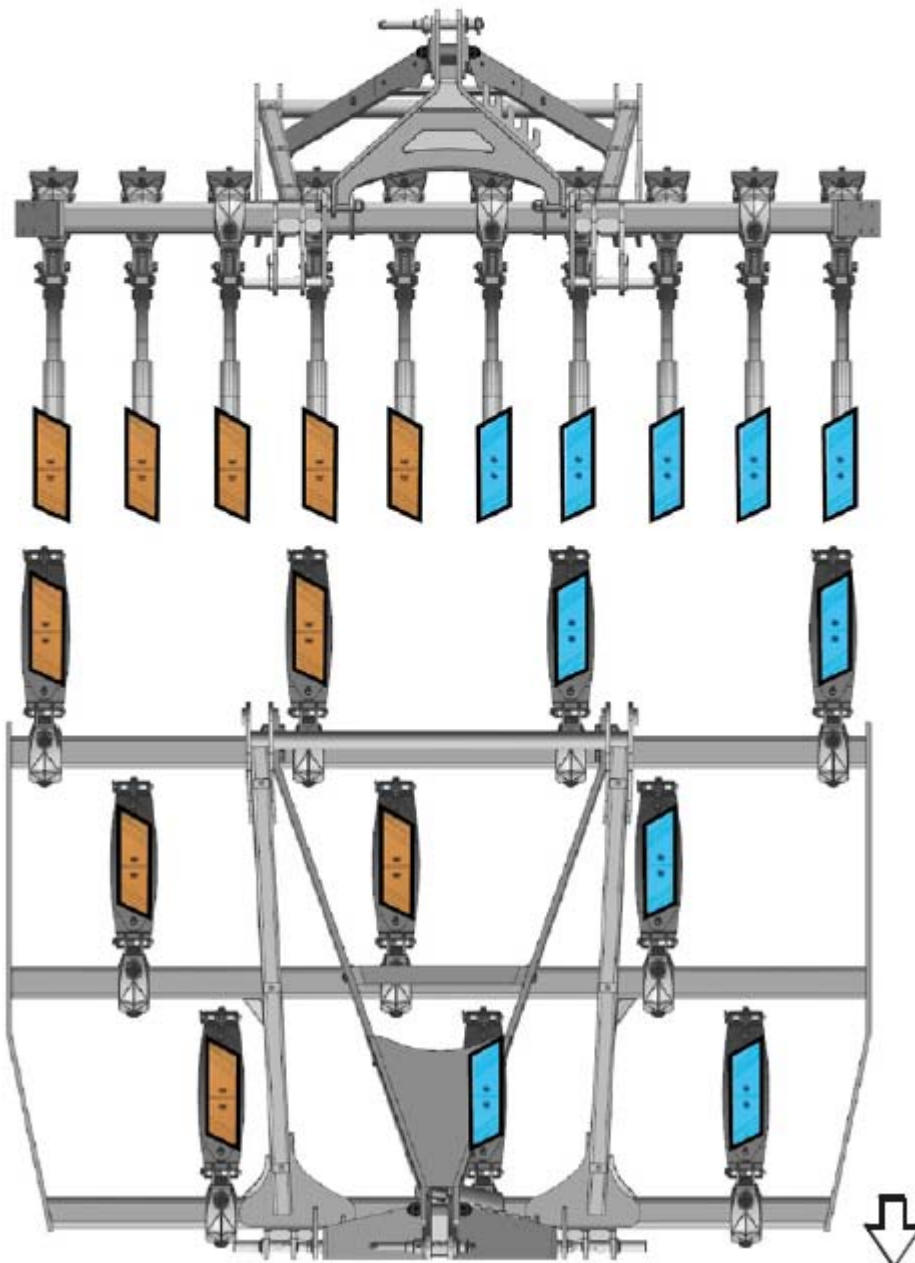



Lighting kit - Europe

Front signs assembly

Mounting EC = Mounting North America

Parts

Image	Reference	Description	Qty
	RF18077	U-BOLT	1
	KG01067761	LOCK NUT M12 8	4

Assembly

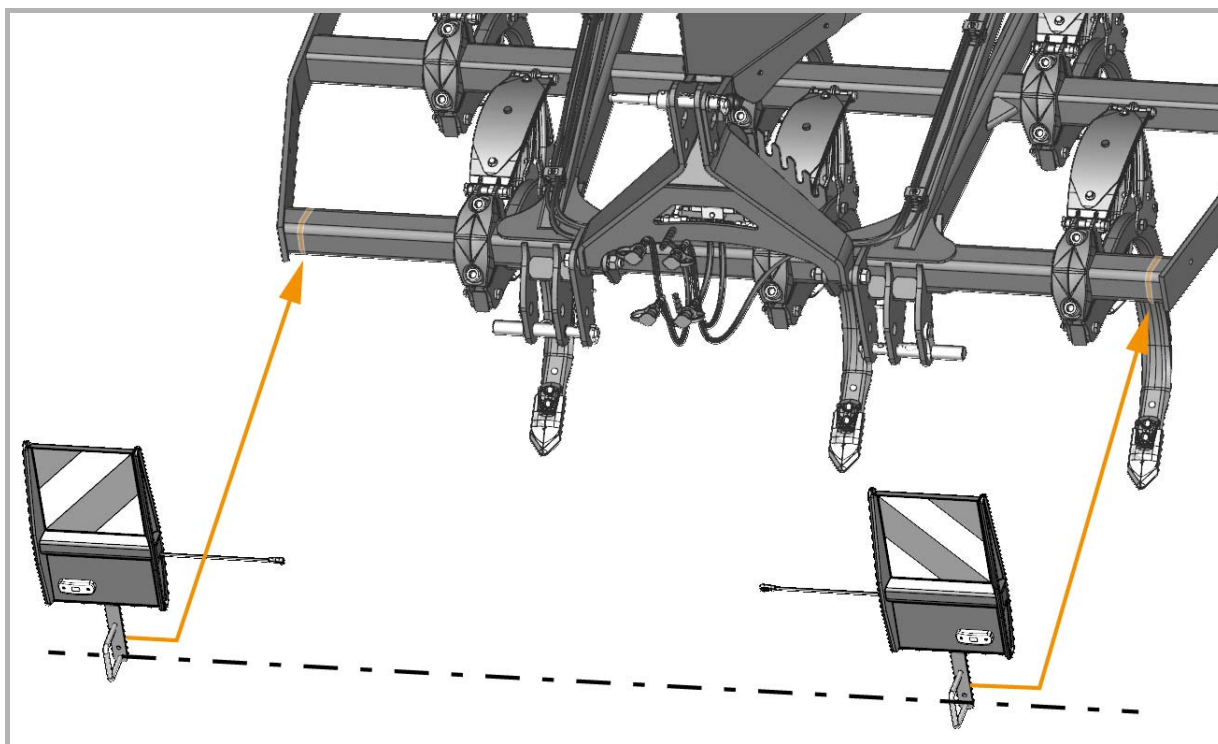



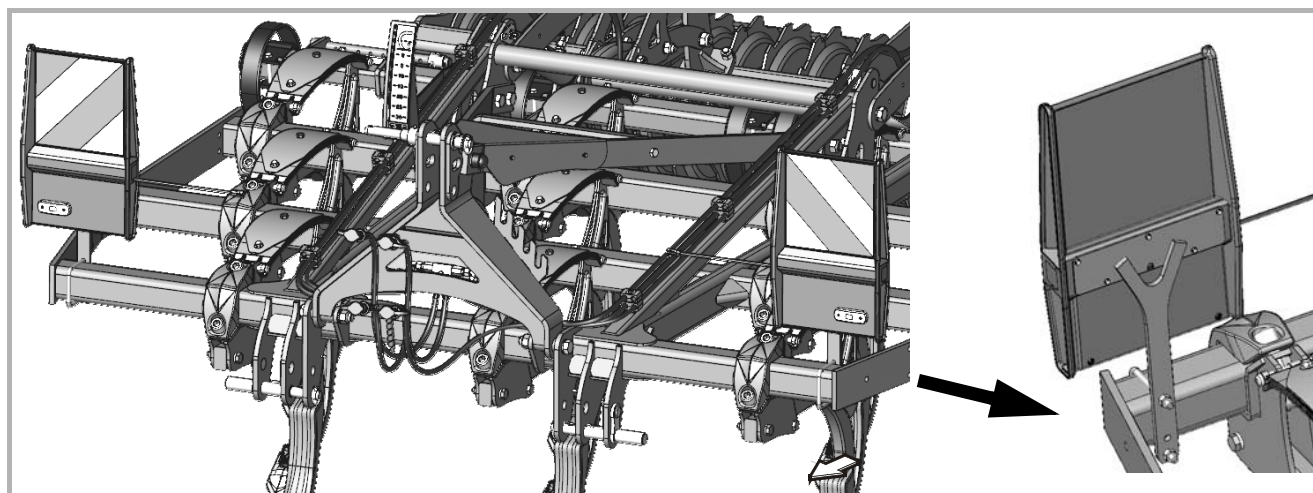



Results



Rear signs assembly

Mounting EC = Mounting North America

Image	Reference	Description	Qty
	KG00353661	HEX. BOLT M8X60	4
	KG01259761	WASHER 8.4 ST	4
	KG01067561	LOCK NUT M8 8	4
	KG00468761	HEX. SCREW M6X16	4
	KG01267261	WASHER M6	4
	A156018261	CLAMP	2
	KG01067361	LOCK NUT M6	4

Lighting kit - Europe

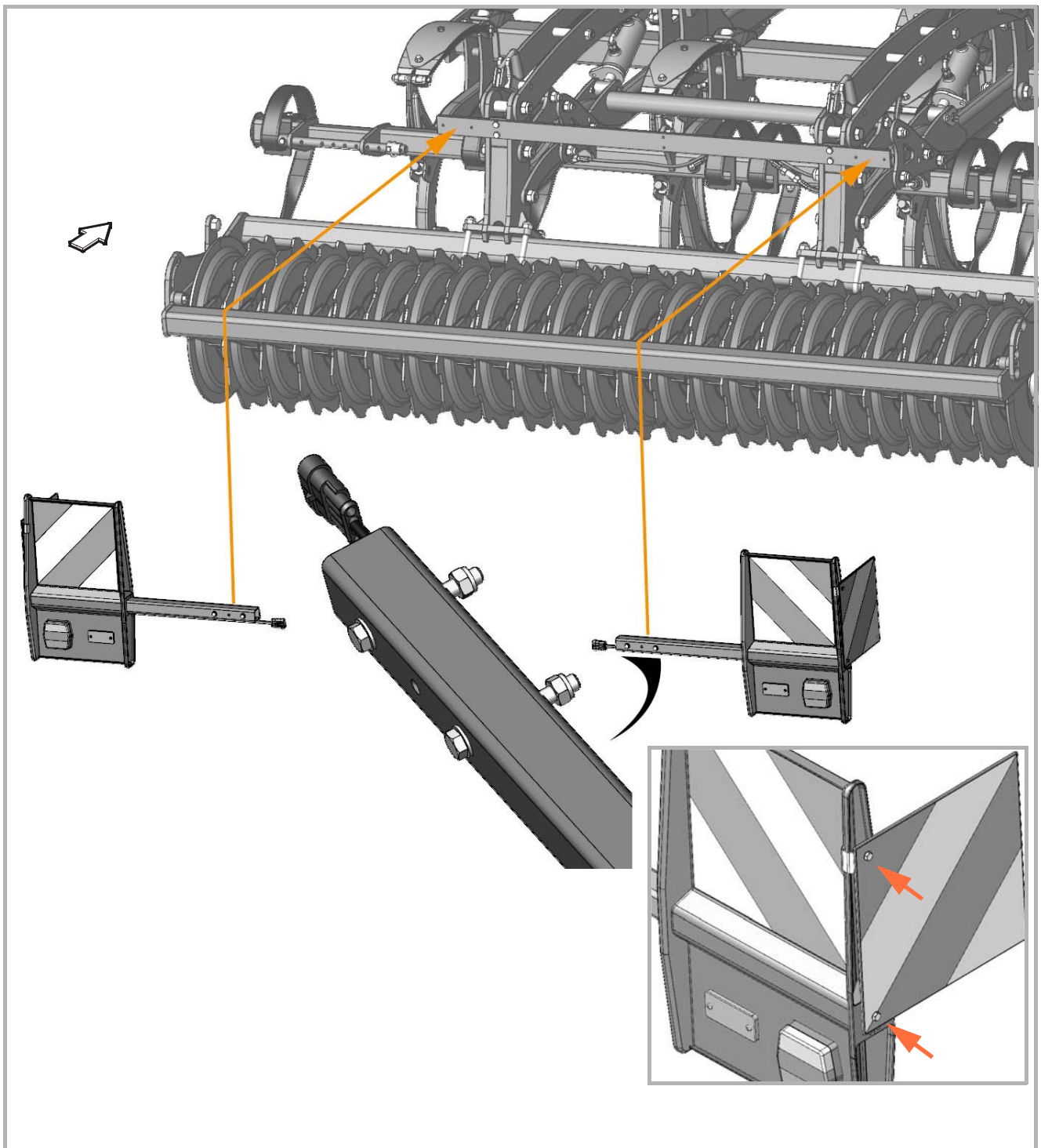

Results

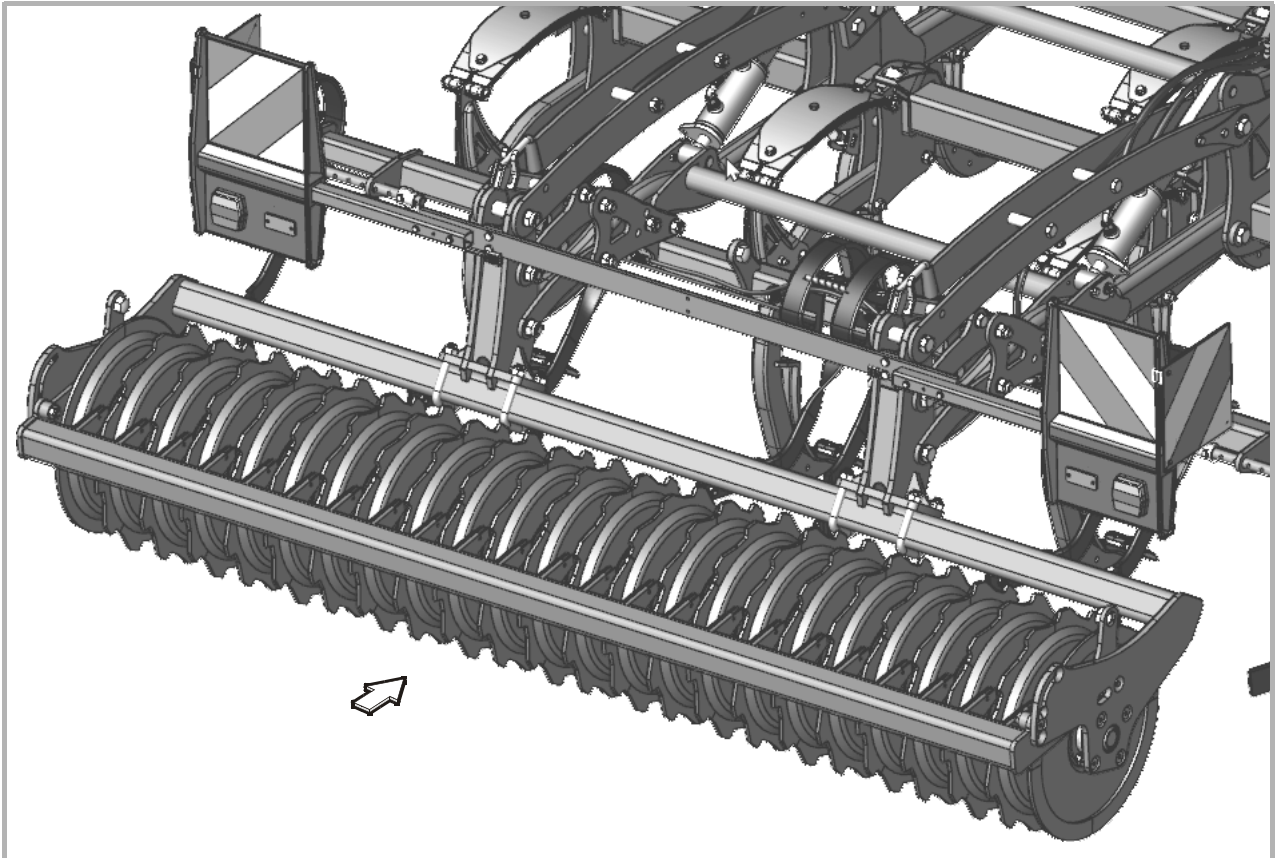

Lighting kit - Europe

Fitting

Signaling systems - RIGID machine

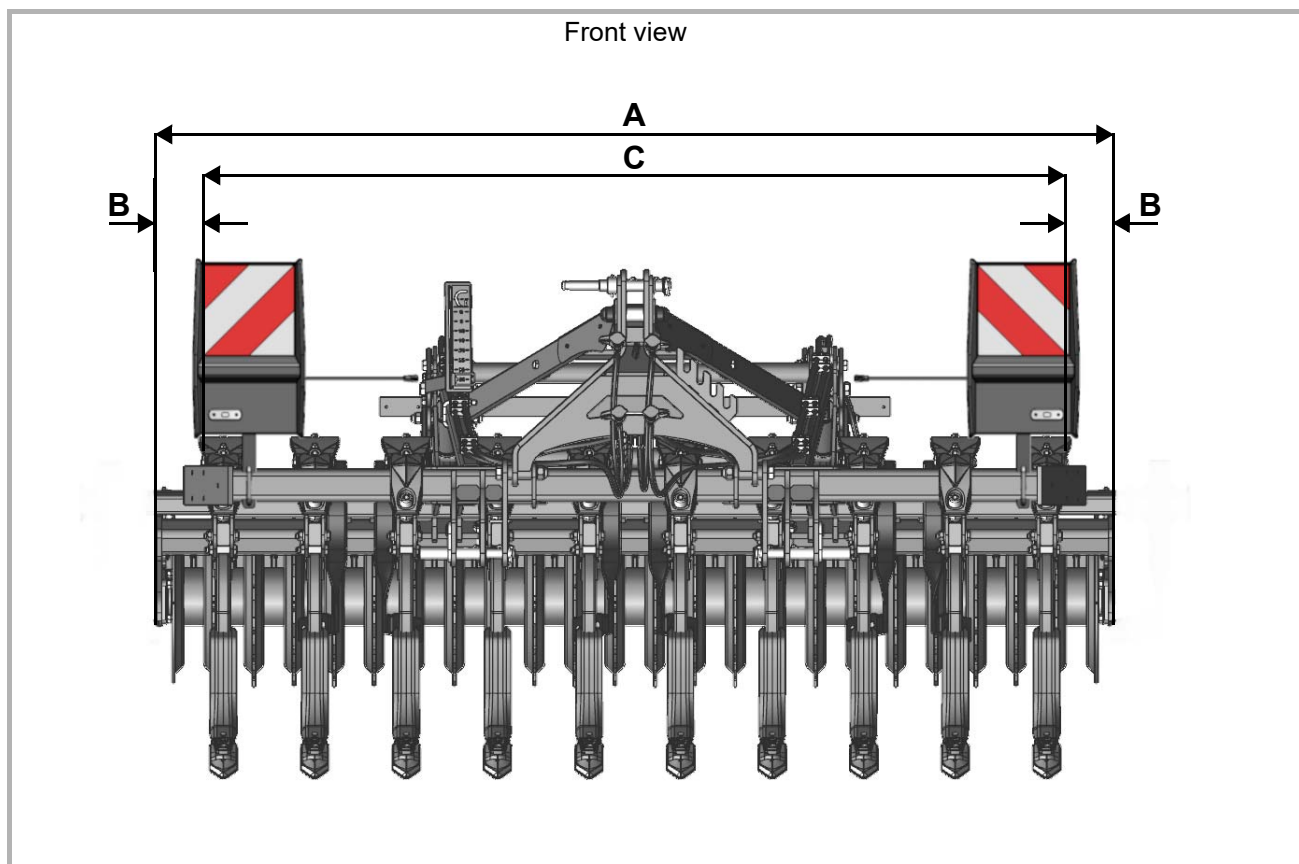

Marking	3M00
---------	------

A	3.00m (9'10)
---	--------------

B	Max. 150mm (approx. 6")
---	-------------------------

C	2.700 m (8'10)
---	----------------

Marking	3M50
---------	------

A	3.50m (11'58)
---	---------------

B	Max. 150mm (approx. 6")
---	-------------------------

C	3.200m (10'6)
---	---------------

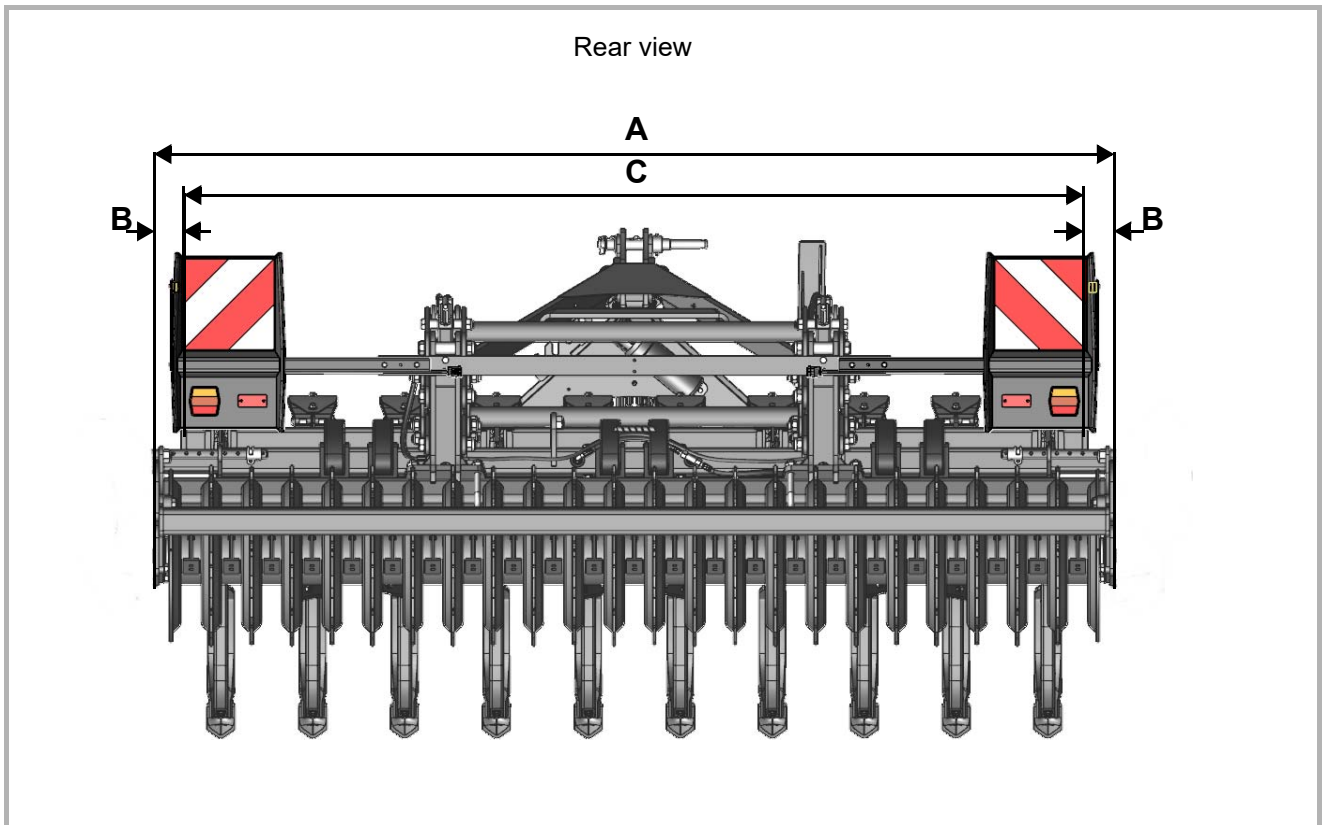

Marking	3M00
---------	------

A	3.00m (9'10)
---	--------------

B	Max. 150mm (approx. 6")
---	-------------------------

C	2.700 m (8'10)
---	----------------

Marking	3M50
---------	------

A	3.50m (11'58)
---	---------------



B	Max. 150mm (approx. 6")
---	-------------------------

C	3.200m (10'6)
---	---------------

Lighting kit - North America

Front signs assembly

Same mounting as EC.



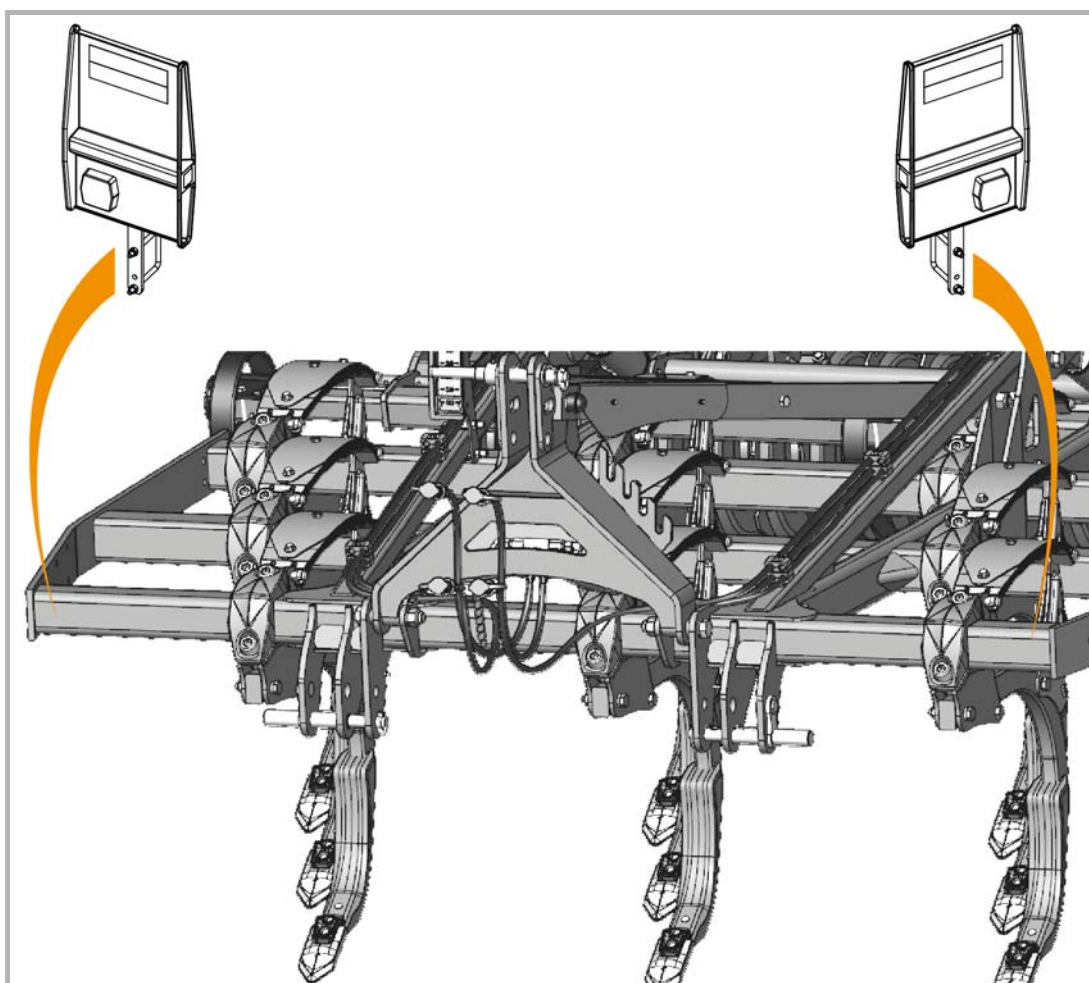

Image	Reference	Description	Qty
	RF18077	U-BOLT DIAM.12	2
	KG01067761	LOCK NUT M12 8	4



Rear signs assembly

Same mounting as EC, except Slow Moving Vehicle plate below.

Parts

Image	Reference	Description	Qty
	KG00353661	HEX. BOLT M8X60	4
	KG01259761	WASHER 8.4 ST	4
	KG01067561	LOCK NUT M8 8	6
	KG00353161	HEX. SCREW M8X35	2

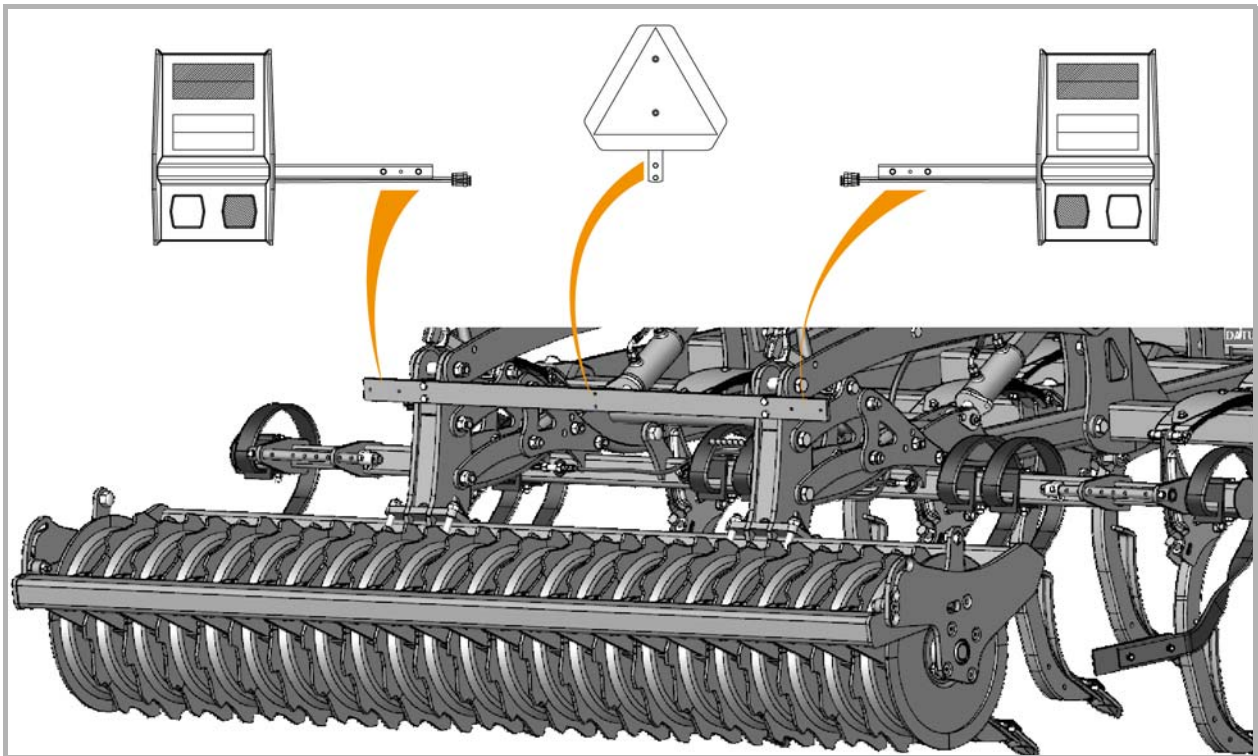

Lighting kit - North America

Fitting

Signaling systems - RIGID machine

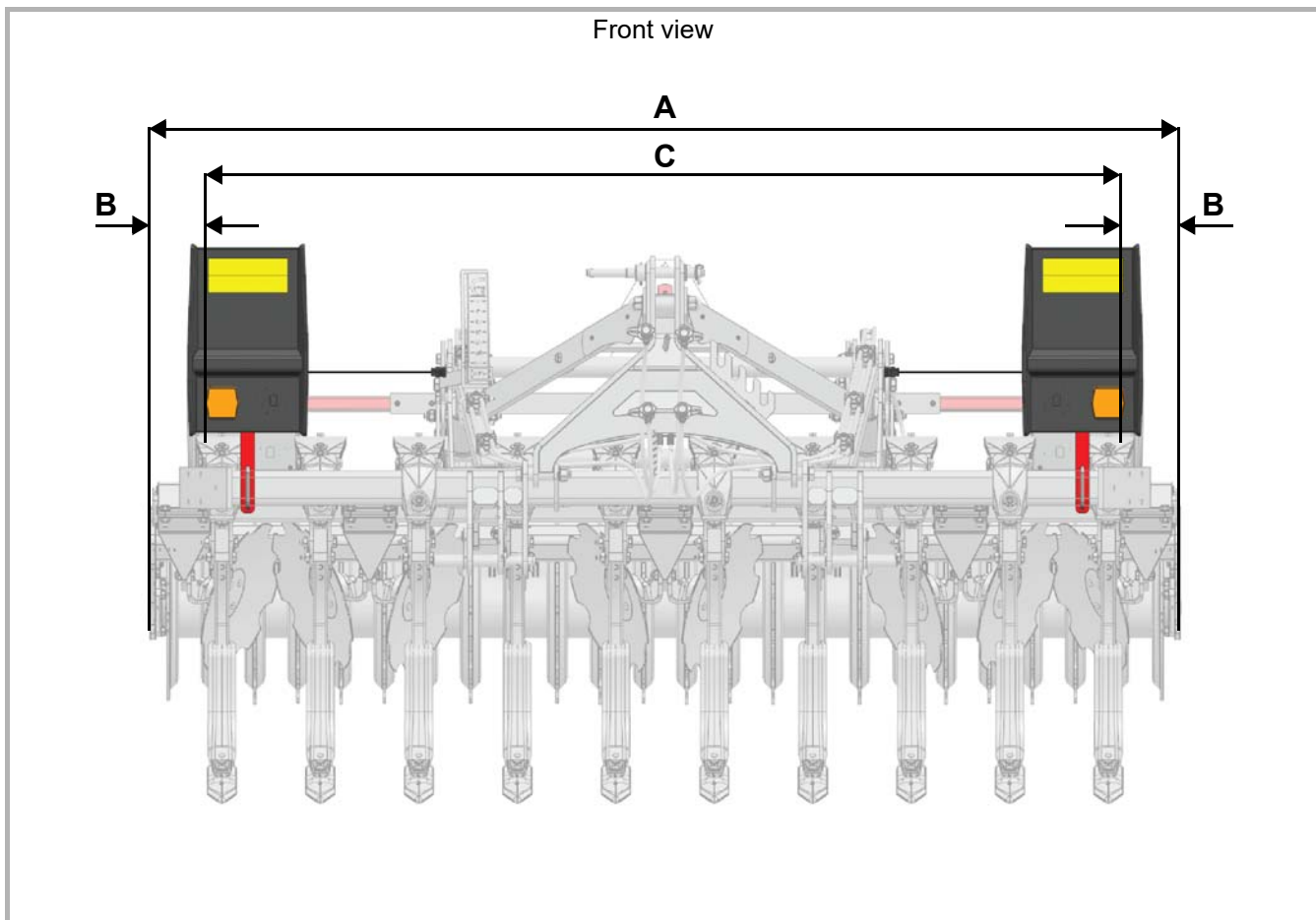

Marking	3M00
---------	------

A	3.00m (9'10)
---	--------------

B	Max. 150mm (approx. 6")
---	-------------------------

C	2.700 m (8'10)
---	----------------

Marking	3M50
---------	------

A	3.50m (11'58)
---	---------------

B	Max. 150mm (approx. 6")
---	-------------------------

C	3.200m (10'6)
---	---------------

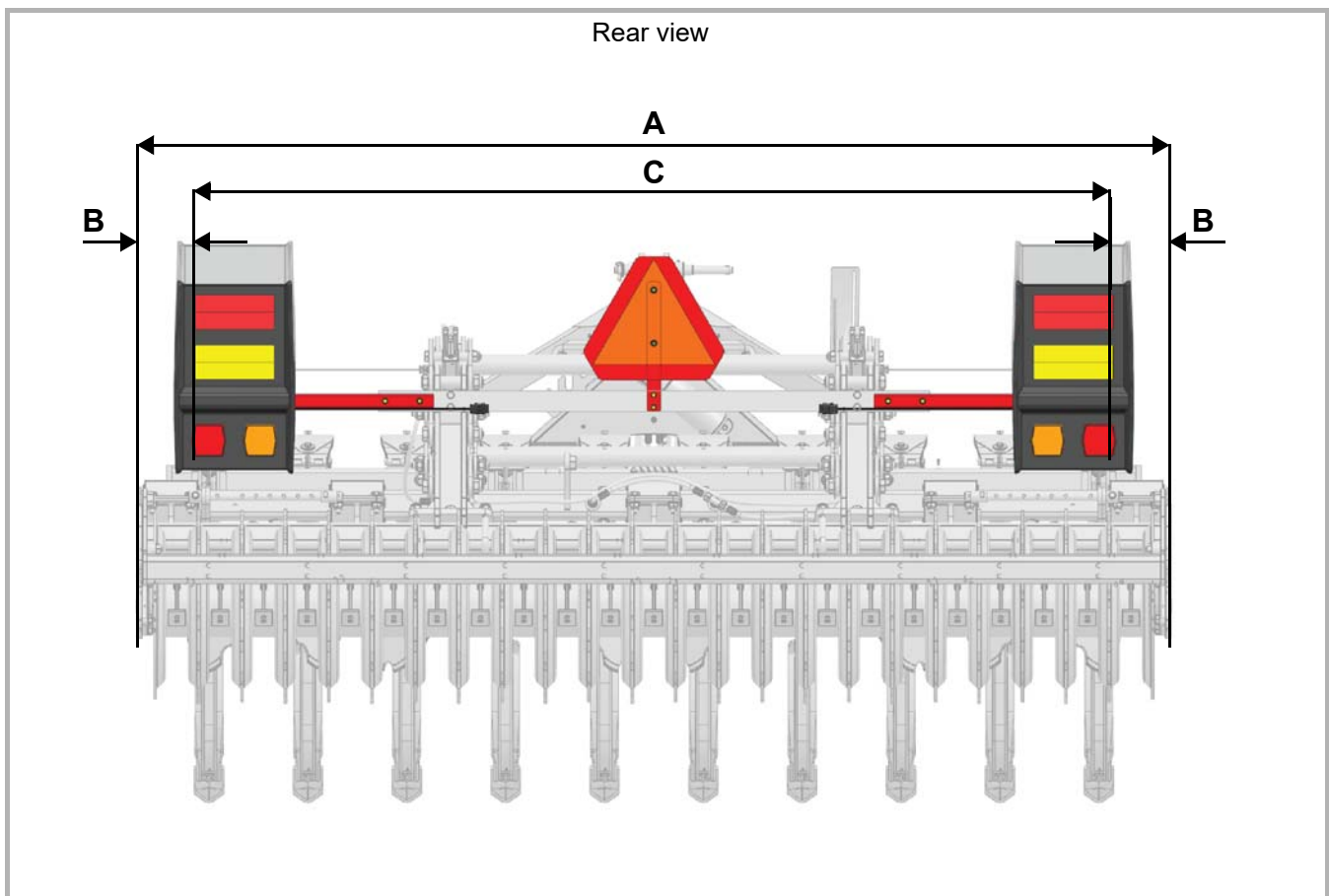

Repère	3M00
--------	------

A	3.00m (9'10)
---	--------------

B	Max. 150mm (approx. 6")
---	-------------------------

C	2.748m (9')
---	-------------

Repère	3M50
--------	------

A	3.50m (11'58)
---	---------------

B	Max. 150mm (approx. 6")
---	-------------------------

C	3.248m (10'8)
---	---------------