

8446
8452

Operator's manual

Original operator's manual

Edition	06.2012
Date of print	04.2022
Language	EN
Machine number	VF65902110 / VF65974001
Model	VF6590 / VF6597
Document number	VF16649093



REGISTER YOUR PRODUCT NOW:
MY.KVERNELAND.COM

Machine identification

In order for your dealer to assist you as efficiently as possible, you will need to provide some information about your machine. Please enter the details here:

Designation 8446 8452

Operating width 4.60 m / 5.20 m

Weight 492 kg/520 kg

Machine number VF659_ _ _ _ _

Accessories

Address of supplier

Address of the manufacturer
Kverneland Group Kerteminde AS
Taarupstrandvej 25
DK-5300 Kerteminde
Denmark
Tel: +45 65 19 19 00

By registering your Kverneland product at my.kverneland.com you will benefit from easy access to Kverneland's online service tools and updated information.



Preface	4	Operation	53
Target group for this operator's manual	4	Safety	53
Symbols used	5	General	54
Safety	7	Crop processing	54
For your safety	7	Using the machine	55
Who is allowed to operate the machine?	11	Border tedding	57
General safety information	11	Cleaning and care	59
Coupling	14	Safety	59
Hydraulics	15	General	60
Road transport	16	Cleaning	60
Operation	17	Care	60
Uncoupling	18	Parking and storage	61
Care and maintenance	19	Setting down the machine in a secure position	
Distance from the centre of gravity	21	61	
Further regulations	23	General	62
Getting to know the machine	24	After the end of the season	63
Range of application	24	Maintenance	64
Features of the implement	24	Safety	64
Designation of components	25	General	66
Technical specifications	26	Screwed connections	67
Delivery and assembly	30	Lubrication points for grease lubrication	70
Checking the scope of delivery	30	Lubricating the PTO shafts	71
Adapting the PTO shaft	31	Slip clutch	71
Prepare the top link	33	Filling quantities	72
Coupling the machine	34	Tyres	73
Safety	34	Hydraulics	74
General	34	Accessories	75
Coupling the three-point linkage	35	Accessories	75
Inserting the parking stand	37	Fault elimination	78
Coupling the PTO shaft	38	Fault	78
Connections	39	Circuit diagrams	79
Connecting hydraulics	40	Hydraulic diagram	79
Preparing for operation	42	Lighting circuit diagram [+]	80
Safety	42	Decommissioning	81
Folding the machine into the work position	43	Disposal	81
Road transport	46	Original EC Declaration of Conformity	82
Safety	46	Index	83
Prior to road transport	47		
Folding the machine into the transport position	48		
48			
Road transport	49		
Preparations on the field	51		
Safety	51		
General	52		
Folding the machine into the work position	52		

Target group for this operator's manual



Simplified illustrations for better understanding

Illustrations of the machine in the operator's manual are shown without protective equipment – or with the protective equipment open – for better understanding. Be sure to observe the safety information and follow the handling instructions in the operator's manual. Serious or fatal injury may be caused as a result.

This operator's manual is aimed at trained agriculturists and persons who are otherwise qualified for agricultural activities and have received instruction in working with this machine.

For your safety

You must familiarise yourself with the contents of this operator's manual before assembly or initial operation of the machine. In this way, you will achieve optimum work results and operational safety. The operator's manual forms an integral part of the machine and must always be kept to hand. This will ensure that you:

- avoid accidents.
- comply with warranty conditions.
- have a fully functional machine in good working order at all times.

Training and instruction

Your dealer will provide instruction on operation and care of the machine.

Information for the employer

All personnel are to be regularly, but at least once a year, instructed on the use of the machine, in accordance with the regulations of the national organisation for Health and Safety at Work. Untrained or unauthorised persons are not permitted to use the machine.

You are responsible for ensuring that the machine is operated and maintained safely. Make sure that you and all other persons that operate, maintain or work in close proximity with the machine are familiar with the operating and maintenance regulations, as well as the corresponding safety instructions in this operator's manual.

Symbols used

In this operator's manual, the following symbols and terms have been used:

- A bullet point accompanies each item in a list.
- ▶ A triangle indicates operating functions which must be performed.

→ An arrow indicates a cross-reference to other sections of this manual.

[+] A plus sign indicates additional equipment which is not included in the standard version.



The warning triangle indicates warning information. Failure to observe these safety instructions can result in:

- Moderate to serious injury
- Fatal injury

The warning information in the operator's manual is specifically associated with individual operations and instructions. It is important to observe the warning information before these operations are carried out.

In the »Safety« chapter, you will also find safety information which is not related to individual operations, but rather is designed to encourage safety-conscious behaviour in various situations.



The information triangle indicates important information. Failure to observe these safety instructions can result in:

- Serious faults in the correct operation of the machine
- Damage to the machine

We have also used pictograms to help you find instructions more quickly:



The "Information" pictogram indicates tips and additional information.



The "Examples" pictogram indicates examples that assist understanding of the instructions.



The spanner indicates tips for assembly or adjustment work.



This arrow in the diagram shows the direction of travel.



▶ Switch on the tractor.



▶ Switch off the tractor engine, put the parking brake in the park position, remove the ignition key and secure the tractor against rolling away.



▶ Open the ball valve.



▶ Close the ball valve.



The grease gun indicates the points that must be lubricated using the grease gun.



The brush indicates the points that must be lubricated using the brush.



For your safety

Familiarise yourself with your equipment and its limitations. Read the entire manual before attempting to put the machine into operation and to use it.

This chapter contains general safety instructions. Each chapter of the operator's manual contains additional specific safety information which is not described here. Observe the safety information:

- in the interest of your own safety.
- in the interest of the safety of others.
- to ensure the safety of the machine.

Numerous risks can result from handling agricultural machinery in the wrong way. Therefore, always work with particular care and never under time pressure.

Information for the employer

Inform all persons who work with the machine about this safety information at regular intervals and in accordance with statutory regulations.



Warning signs

Safety-related labels attached to the machine indicate potential hazards. The labels must not be removed. Illegible or missing labels should be replaced. You can obtain new labels as replacement parts from your dealer.

Warning signs on the machine

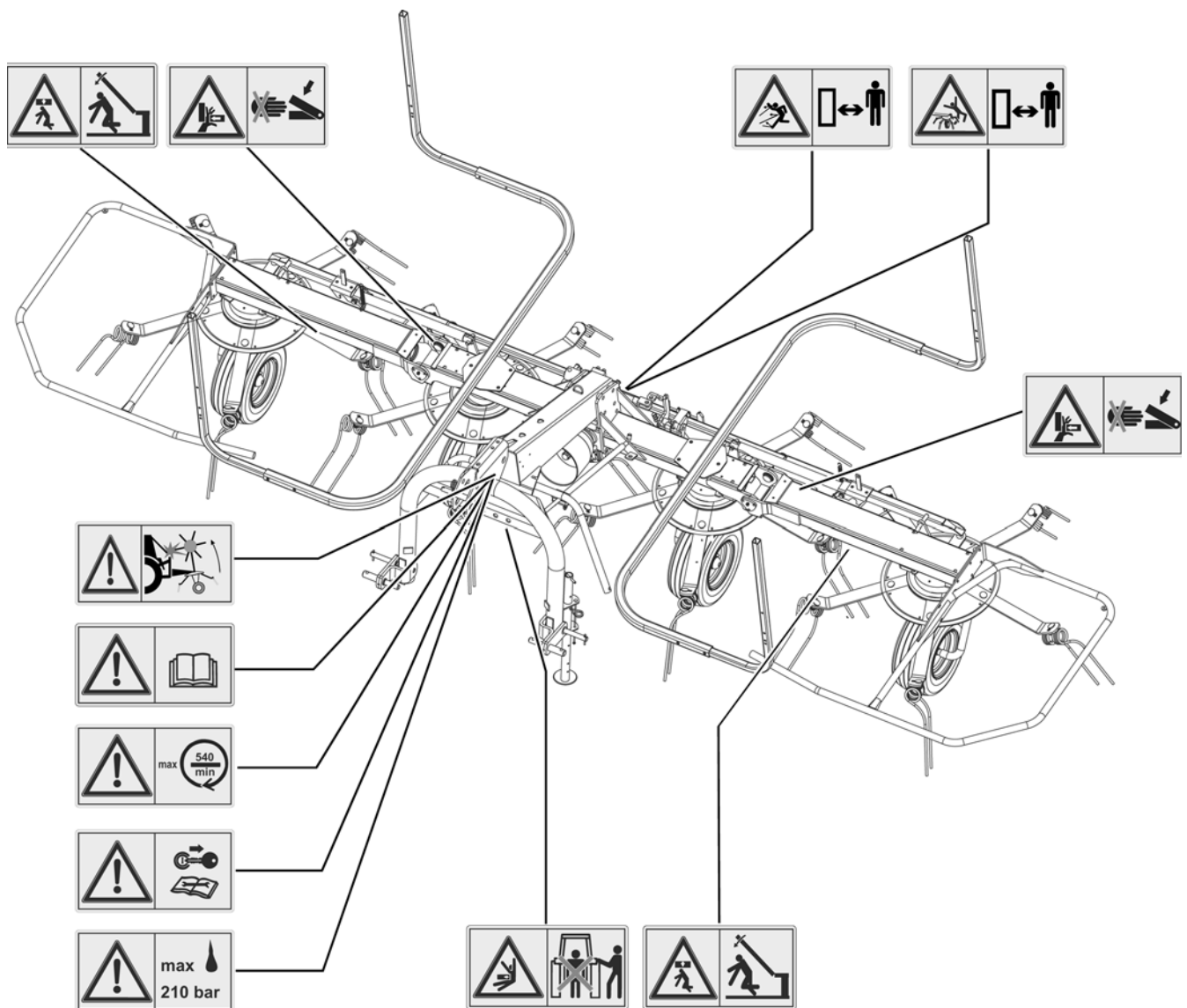



Meaning of warning signs



Read the operator's manual

Read and follow the operating and safety instructions before using the machine for the first time. The machine must not be used for the first time until the operator's manual has been read and understood. This applies in particular to the safety information. Otherwise, serious or fatal injury may be caused as a result.



Switch off the engine

Only perform maintenance, repair and adjustment work when the machine is shut down. Otherwise, serious or fatal injury may be caused as a result.



Distance from the rotor

Maintain a safe distance from the rotor when it is rotating. Nobody may remain in close proximity to the machine when rakes and swathers are running. Otherwise, serious or fatal injury may be caused as a result.



Distance from tractor

When the machine is being coupled, uncoupled or operated, there should be no-one between the tractor and the machine. Otherwise, serious or fatal injury may be caused as a result.



Risk of crushing

Never reach into an area where there is a risk of crushing if parts in that area are still likely to move. Otherwise, serious or fatal injury may be caused as a result.



Caution, parts ejected at speed

Hazard caused by parts which may become detached when the drive is in operation, and ejected at speed. Maintain a safe distance. Otherwise, serious or fatal injury may be caused as a result.



No persons within the slewing range

There is an acute risk of injury within the slewing range from machine parts which are slewing or folding. Otherwise, serious or fatal injury may be caused as a result.



PTO shaft speed 540 rpm

The specified maximum PTO shaft speed of 540 rpm must not be exceeded. Otherwise, damage to the machine may be caused as a result.



Do not exceed the maximum hydraulic pressure



The tractor's hydraulic pressure on the machine's hydraulic system must not exceed 210 bar. Otherwise, damage to the machine may be caused as a result.



Caution when lifting

When lifting the machine, make sure that you always maintain a sufficient space between the machine and the rear window of the tractor. Otherwise, damage to the machine and personal injury may be caused as a result.

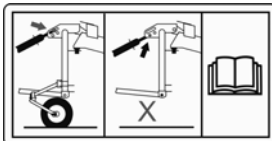

Information about coupling the top link

When coupling the top link, ensure that the hitch pin is correctly fitted. Otherwise, damage to the machine may be caused as a result:

- When using the optional support wheel:
 - ▶ Peg the hitch pin in the elongated hole and secure it with a safety splint.
- Without the support wheel:
 - ▶ Peg the hitch pin in the hole and secure it with a safety splint.



Lubrication points

Lubrication points are marked with an information label. Lubricate the machine in accordance with the instructions in the "Maintenance" chapter.

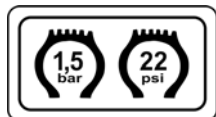

Check tyre pressures

Check tyre pressures on a regular basis. Incorrect tyre pressures reduce the service life of a tyre and cause unstable driving characteristics. Otherwise, damage to the machine may be caused as a result.



Who is allowed to operate the machine?

Only qualified personnel

Only qualified persons who have been informed of the dangers associated with handling the machine are permitted to operate, service or repair the machine. This knowledge can be gained via agricultural training, technical training or intensive instruction.

General safety information

The general safety information and warning signs apply to every phase of the life cycle of the machine and to every application.



Switch off the tractor and secure it

Before you dismount:

- ▶ Switch off the PTO shaft drive.
- ▶ Lower all implements.
- ▶ Switch all operating controls to the neutral or park position.
- ▶ Put the tractor's parking brake into the park position.
- ▶ Switch off the tractor engine, put the parking brake in the park position, remove the ignition key and secure the tractor against rolling away.
- ▶ Remove the ignition key.
- ▶ Secure the tractor against rolling away.

An unsecured tractor can run you over or trap you. Serious or fatal injury may be caused as a result.

Operate for the first time only after proper training

The machine may only be put into operation if thorough training has been carried out by an authorised dealer or by an employee of the manufacturer. Operation without proper training can lead to damage to the machine due to incorrect operation, or may cause accidents.

Safety is your responsibility

Follow the safety instructions. Ensure that all operators comply with the safety instructions. Prevent serious or fatal accidents by following the safety instructions.

Instructions in the event of malfunctions

In the event of a malfunction

- ▶ shut down,
- ▶ stop and secure the machine immediately.
- ▶ Immediately rectify the faults, if you are qualified to do so, or
- ▶ commission an authorised dealer.

Operating a faulty machine can cause accidents or damage.



No persons in the working area

Ensure that no persons – children in particular – are present in the slewing and working area of the machine. Persons could be caught by the machine within this area. Fatal injury may be caused as a result.

Correct working conditions

Ensure that the tractor and the machine are always in perfect working condition. Make sure that the tractor brakes work in conjunction with the machine. Also follow the instructions in your tractor's operator's manual.

Never manoeuvre or position in the transport position

Never manoeuvre machines in the transport position if the machine is not coupled properly. When manoeuvring, also make sure that all parking stands are retracted and secured. Otherwise, damage to the machine or life-threatening injuries may be caused as a result.



Switch off the PTO shaft drive when raising the machine

Switch off the tractor's PTO shaft drive if people – especially children – may enter the working area of the machine when you

- raise the machine,
- raise the side devices or
- raise the rotors to the headland position.

Rotating, unprotected parts can damage the machine and cause life-threatening injuries.



Switch off the tractor PTO shaft drive

Switch off the PTO shaft drive on the tractor when changing from work to transport position (and vice versa). Wait for moving parts to come to a stop. If this requirement is ignored, the consequence may be damage to the machine and even life-threatening injuries.



No reversing while the drive is running

Never drive in reverse with the PTO shaft drive running and in the work position if people may enter the working area of the machine. Switch off the PTO shaft drive. Rotating, unprotected parts can damage the machine and cause life-threatening injuries.

Specified workwear

Do not wear baggy, loose-fitting or other unsuitable clothing. Loose fitting items of clothing may become caught in rotating parts. Wear workwear and protective clothing which is suitable for the working environment and the operating conditions. Wear workwear and protective clothing, as specified by the Accident Prevention and Insurance Association. Serious or fatal injury may be caused as a result.

**No riding on the machine**

Persons or objects must never be transported on the machine. Carrying passengers – particularly children – on the machine is life-threatening and prohibited. Serious or fatal injury may be caused as a result.

Safety for children

Never assume that children will remain where you last saw them. Be alert and shut down the machine if children are in the working area of the machine. Prohibit children from playing on or around the machine and from operating the machine.

Never work on the machine while it is running

No operations may be performed on the machine while it is running. Objects or persons can be caught, drawn in or crushed. Serious or fatal injury may be caused as a result.

Safe distance from raised and unsecured loads

Never work under suspended loads. Maintain a sufficient distance from raised and unsecured loads. Serious or fatal injury may be caused as a result.

Only use the PTO shaft specified

Use only the PTO shafts specified by the manufacturer and read the attached operator's manual carefully. Adjust the length of the PTO shaft as required. Incorrect PTO shaft lengths can cause damage to the machine and personal injury.

Check and fasten the PTO shaft guard in position

The rotating PTO shaft is protected by the PTO shaft guard. Ensure that the guard is not damaged. Fasten the PTO shaft guard in position by connecting the chains on the implement and the tractor. Unguarded PTO shafts can cause life-threatening injuries.

Make sure the machine is standing level

Before changing from the transport to the work position (and vice versa), make sure the machine is standing level. The machine could tip over, particularly on hillside locations. Otherwise, damage to the machine and serious or fatal injury may be caused as a result.

Do not make any modifications to the machine

No modifications of any kind may be made to the machine. Unauthorised modifications can adversely affect the correct operation and safety of the machine and shorten its service life. Unauthorised modifications to the machine render the manufacturer's guarantee null and void and free the manufacturer from all liability.



Maximal PTO shaft speed: 540 rpm

The specified maximum PTO shaft speed of 540 rpm must not be exceeded. A higher PTO shaft speed will damage the machine.

Unrestricted field of vision to the rear

After it has been coupled, ensure that you have an unrestricted view of the machine, in both its work and transport positions. Otherwise, dangerous situations may not be detected in good time. Accidents or damage may be caused as a result.

Keep the rear window closed

Always keep the rear window of the tractor cab closed when folding. During the folding procedure, an open rear window can be irreparably damaged. A damaged rear window can cause personal injury.

Coupling

Increased risk of injury

When the machine is being coupled to the tractor, there is an increased risk of injury. Therefore:



- Switch off the tractor engine, put the parking brake in the park position, remove the ignition key and secure the tractor against rolling away.
- Never stand between the tractor and machine.
- Lock the PTO shaft securely on the PTO stub shafts of the tractor and the machine.

If this requirement is ignored, the consequence may be damage to the machine and even life-threatening injuries.

Attaching electrical connections after assembly

The electrical supply to the tractor must not be connected when the lighting equipment is being fitted. Otherwise, short circuits may occur and the electronic system may be damaged.

Observe the operator's manual of the PTO shaft manufacturer

Observe the operator's manual of the PTO shaft manufacturer. It will provide you with instructions on how to handle the PTO shaft correctly. If these instructions are ignored, damage may be caused to the PTO shaft and machine.

Risk of tipping due to unsecured quick-release couplings

When the machine is coupled to tractors with lower link quick-release couplings, the quick-release couplings must be secured against unintentional opening. If the quick-release couplings open unintentionally, the tractor and machine may tip over. If this requirement is ignored, the consequence may be damage to the machine and even life-threatening injuries. Also follow the instructions in your tractor's operator's manual.



Hydraulics

Hydraulic connection at zero pressure only

Only connect hydraulic hoses to the tractor hydraulic system if the tractor and machine hydraulic system is at zero pressure. A pressurised hydraulic system can trigger unpredictable movements of the machine and can cause serious machine damage and personal injury. Serious or fatal injury may be caused as a result.

High pressures in the hydraulic system

The hydraulic system is under high pressure. Regularly check all lines, hoses, and screwed connections for leaks and externally visible damage. Only use suitable tools when looking for leaks. Rectify any damage immediately. Oil escaping under pressure may result in injuries and fires. Seek medical attention immediately if injuries occur.

Replace hydraulic hoses every six years or sooner

Hydraulic hoses age without showing externally visible signs. Replace hydraulic hoses every six years or sooner. Use hydraulic hoses only with the same technical specifications. The required information is printed on the hydraulic hose. Defective or incorrect hydraulic lines can cause serious or fatal injuries.



Road transport

Ensuring road safety

The machine must conform to current national traffic regulations if you intend to drive with it on public roads. Ensure the following:

- Lighting, warning and protective equipment must be fitted.
- The permissible transport widths and weights, axle loads, tyre load-bearing capacities, laden weights and national speed restrictions must be complied with.
- The maximum permissible road transport speed must be complied with, but not exceed 40 km/h (25 mph).
- Before driving on public roads, fold in all guard bars and rotors and secure the machine.
- The machine should only be towed by agricultural or forestry tractors.

The empty weight of the tractor must be greater than the weight of the machine. The driver and keeper of the vehicle are liable should these conditions not be observed.

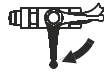

Close the ball valve

Close the ball valve before driving on the road. If the ball valve is open and there is an operating error, the machine may drop or swing out unexpectedly. This can result in traffic accidents and accidents causing serious or fatal injuries.

Check tyre pressures

Check tyre pressures on a regular basis. Incorrect tyre pressure reduces the service life of the tyre.

Altered driving and braking performance

Driving and braking characteristics are altered when the machine is coupled or hitched to the tractor. When cornering, take the overall width and balancing weight of the machine into consideration. Adjust your driving speed accordingly. A driving style which is not adapted to conditions can cause accidents. Accidents with serious or fatal injuries may be caused as a result.

Speed adjustment

In poor road conditions and at high speeds, significant forces can be generated which subject the tractor and machine material to high or excessive stresses. Adjust your driving speed to the road conditions. A driving style which is not adapted to conditions can cause accidents. Accidents with serious or fatal injuries may be caused as a result.

**Check hitch pins**

Hitch pins must be in perfect condition. Hitch pins must show no signs of wear and be properly secured. Otherwise, hitched machines may detach themselves of their own accord. Accidents with serious or fatal injuries may be caused as a result.

Check release ropes on quick-release couplings

Release ropes must hang loose and must not allow a release in their lowered position. Hitched machines may otherwise detach themselves from the lower link hitching system of their own accord. Accidents with serious or fatal injuries may be caused as a result.

Operation

Operate for the first time only after proper training

The machine may only be put into operation after proper training has been provided by an employee from a dealership or the manufacturer, or by a factory representative. Operation without training can lead to damage to the machine due to incorrect operation, or cause accidents.

Make sure the machine is in perfect working condition

Do not operate the machine unless it is in perfect working condition. Check all key components and their correct operation before use. Replace defective components. Defective components can cause material damage and personal injury.

Check the protective equipment

The protective equipment must not be removed or by-passed. Check all protective equipment before using the machine. Unprotected machine parts can cause serious or fatal injury.

Check the immediate vicinity

Check the area immediately surrounding the machine before driving off, and continually during operation. Make sure that you have an adequate view. Only begin work when the immediate vicinity is cleared of any persons or objects. Serious or fatal injury may be caused as a result.



Retighten all nuts, bolts and screws

Regularly check that nuts and bolts are correctly tightened. Retighten bolts if necessary. Nuts and bolts can work loose when the machine is used. Damage to the machine or accidents may be caused as a result.

→ Observe the correct torque specifications in chapter »Screw and bolt tightening torques« on page 68.

The PTO shaft continues turning after it has been switched off

After the PTO shaft drive on the tractor has been switched off, the machine continues to run due to the moment of inertia. Maintain a sufficiently safe distance until all moving parts have come to a complete standstill. Otherwise, damage to the machine and serious or fatal injury may be caused as a result.

Cornering and turning manoeuvres

Centrifugal forces are in operation during cornering. The machine's centre of gravity at the rear of the tractor is displaced. Be aware of the turning radius and the moment of inertia. A driving style which is not adapted to conditions can cause accidents. Accidents with serious or fatal injuries may be caused as a result.

Uncoupling

There is an increased risk of injury when uncoupling the machine from the tractor. Therefore:



- Switch off the tractor engine, put the parking brake in the park position, remove the ignition key and secure the tractor against rolling away.
- Never stand between the tractor and machine.
- Set the machine down on firm, secure and level ground.
- Ensure that the parking stand is securely locked.
- Place the PTO shaft in the holder provided.
- Secure the machine against rolling away.

Failure to observe these instructions can result in serious or fatal injury.



Care and maintenance

Observe the care and maintenance intervals

Observe prescribed intervals for maintenance checks and inspections specified in the operating manual. If these periods are not observed, damage to the machine and accidents may be caused as a result.

Use original parts

Many components have special properties that are essential for the stability and correct operation of the machine. Only spare parts and accessories supplied by the manufacturer have been tested and approved. Other products may adversely affect the correct operation of the machine and safety. Using non-OEM replacement parts renders the manufacturer's guarantee null and void and frees the manufacturer from all liability.



When performing care and maintenance work:

- Switch off the PTO shaft drive.
- Whenever possible, uncouple the tractor.
- Switch off the tractor engine, put the parking brake in the park position, remove the ignition key and secure the tractor against rolling away.
- Ensure the machine is standing on firm, secure and level ground, and provide additional support, if necessary.
- Secure the machine against rolling away.

Only if these regulations are observed can safe working be ensured during care and maintenance work.

Turn off the electrical supply

Disconnect the power supply before working on the electrical system. Systems being supplied with electrical power can cause damage to equipment and injury to persons.

Caution when cleaning with a high-pressure cleaner

Exercise caution when cleaning with a high-pressure cleaner. Bearings, seals and pipe unions are not waterproof. In order to prevent damage to the machine, the bearings, seals and pipe unions must not be exposed to direct contact with the high pressure water jets.

**No aggressive washing additives**

Do not use any aggressive washing additives for cleaning. Uncoated metal surfaces can be damaged.

Before carrying out welding work

Disconnect all electrical connections from the tractor when carrying out welding on the hitched machine. Damage may otherwise be caused to the electrical system.

Retighten all nuts, bolts and screws

All screwed/bolted connections that are loosened during maintenance and repair operations must be retightened. Serious injury and damage to equipment can be caused by loose pin and screwed connections.

→ Observe the correct torque specifications in chapter »Screw and bolt tightening torques« on page 68.



Distance from the centre of gravity

Observe the total weight, axle loads, tyre load-bearing capacity and minimum ballast specifications.

The front or rear attachment of machines must not cause the tractor's permissible total weight, its permissible axle load or its tyre load-bearing capacity to be exceeded. In order for steering capability to be maintained, the front axle must bear at least 20 % of the tractor's unladen weight.

By investing some effort in making the calculations you can determine the:

- Total weight
- Axle load
- Tyre load-bearing capacity
- Minimum ballast

For this calculation, the following data is required:

Data from the tractor's operator's manual

- (A) Unladen weight in kg.
- (B) Front axle load in kg.
- (C) Rear axle load in kg.

Take into consideration any further weights, such as water in the tyres, additional equipment etc.

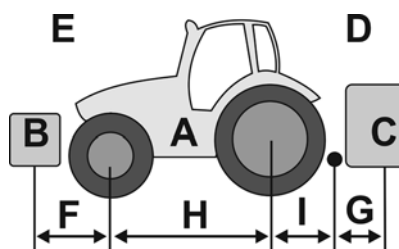

Data from this operator's manual

- (D) Total weight of the machine in the rear attachment. For hitched machines, the supporting load in kg.
- (E) Total weight of the machine in the front attachment in kg.
- (F) Distance between the machine's centre of gravity in the front attachment and front axle midpoint in m.
- (G) Distance between the lower link ball midpoint and the machine's centre of gravity in the rear attachment in m. With hitched machine $G=0$

Data to be measured:

- (H) Tractor's wheel base in m.
- (I) Distance between the rear axle midpoint and the lower link ball midpoint in m.



Calculation

The values (A) to (I) can be inserted in the formulas.

Ballast with front weights

Calculation of the **ballast with front weights** for rear-mounted machines.

$$\text{Front ballast in kg: } \frac{D \cdot (I + G) - (B \cdot H) + (0.2 \cdot A \cdot H)}{F + H}$$

Ballast with rear weights

Calculation of the **ballast with rear weights** for front-mounted machines.

$$\text{Rear ballast in kg: } \frac{(E \cdot F) - (C \cdot H) - (0.45 \cdot A \cdot H)}{H + I + G}$$

Front axle load

Calculating the **actual front axle load (J)**.

$$\text{Front axle load in kg: } \frac{E \cdot (F + H) + (B \cdot H) - D \cdot (I + G)}{H}$$

Total weight

Calculating the **actual total weight (K)**.

$$\text{Total weight in kg: } K = E + A + D$$

Rear axle load

Calculating the **actual rear axle load (L)**.

$$\text{Rear axle load in kg: } L = K - J$$

Tyre load-bearing capacity

Information about the tyre load-bearing capacity of the front and rear wheels can be found in the tyre manufacturer's details.

The front tyre load-bearing capacity for two wheels is equal to twice the permissible tyre load-bearing capacity of a single front wheel. The rear tyre load-bearing capacity for two wheels is equal to twice the permissible tyre load-bearing capacity of a single rear wheel.

Summary

The actual values for the rear axle load must be less than the permissible values given in the tractor's operator's manual. The tyre load-bearing capacity must be greater than the values for the rear axle load given in the operator's manual.

The actual total weight must be less than the permissible total weight given in the tractor's operator's manual. If not, the machine must not be coupled to the tractor.



Further regulations

Observe the regulations

In addition to the safety information listed above, please observe the following:

- Accident prevention regulations.
- Generally recognised safety regulations, occupational health requirements and road traffic regulations.
- The instructions provided in this operator's manual.
- Regulations relating to operation, maintenance and repair.

Warranty

The warranty and manufacturer's liability will no longer be valid if the instructions provided in the chapter on Safety are not observed, if maintenance is inadequate or faulty, if the machine is used for purposes other than those for which it was intended and if it is overstressed, or if impermissible modifications are made to the machine.

Getting to know the machine

Range of application

This product is classified as replaceable equipment in accordance with EC directive 2006/42/EC.

The machine is a rotary tedder that is solely to be used for tedding, turning and swathing mown, stalked material such as straw and hay.

Proper use

Any other use extending beyond this, for example, for silo distribution, any form whatsoever of soil preparation, road sweeping or for the transmission of power to other implements is not an intended use. The manufacturer and dealers are not liable for damage caused by improper use. The risk is borne solely by the user.

Features of the implement

Flexible operation through compact design

With a working width of 4.60 m or 5.20 m and 4 rotors, this rotary tedder is perfectly suited for flexible operation – even in hilly regions.

Small rotors for efficient crop processing

The small rotors are better at picking up and evenly distributing the fodder.

Easy-to-maintain gear box

The machine is equipped with low-maintenance gears and five tine arms per rotor. The gears are easy to maintain as well as low-wear and sturdy.

Border tedding system

The crop is deposited inwards from the field edge by pivoting the running wheel axles. This helps to prevent fodder from being lost.

Simple transformation from work to transport position

The rotary tedder is easily changed from work to transport position. The hydraulic cylinders swivel the rotary tedder into the transport position. Dismounting from the tractor is not required.

Designation of components

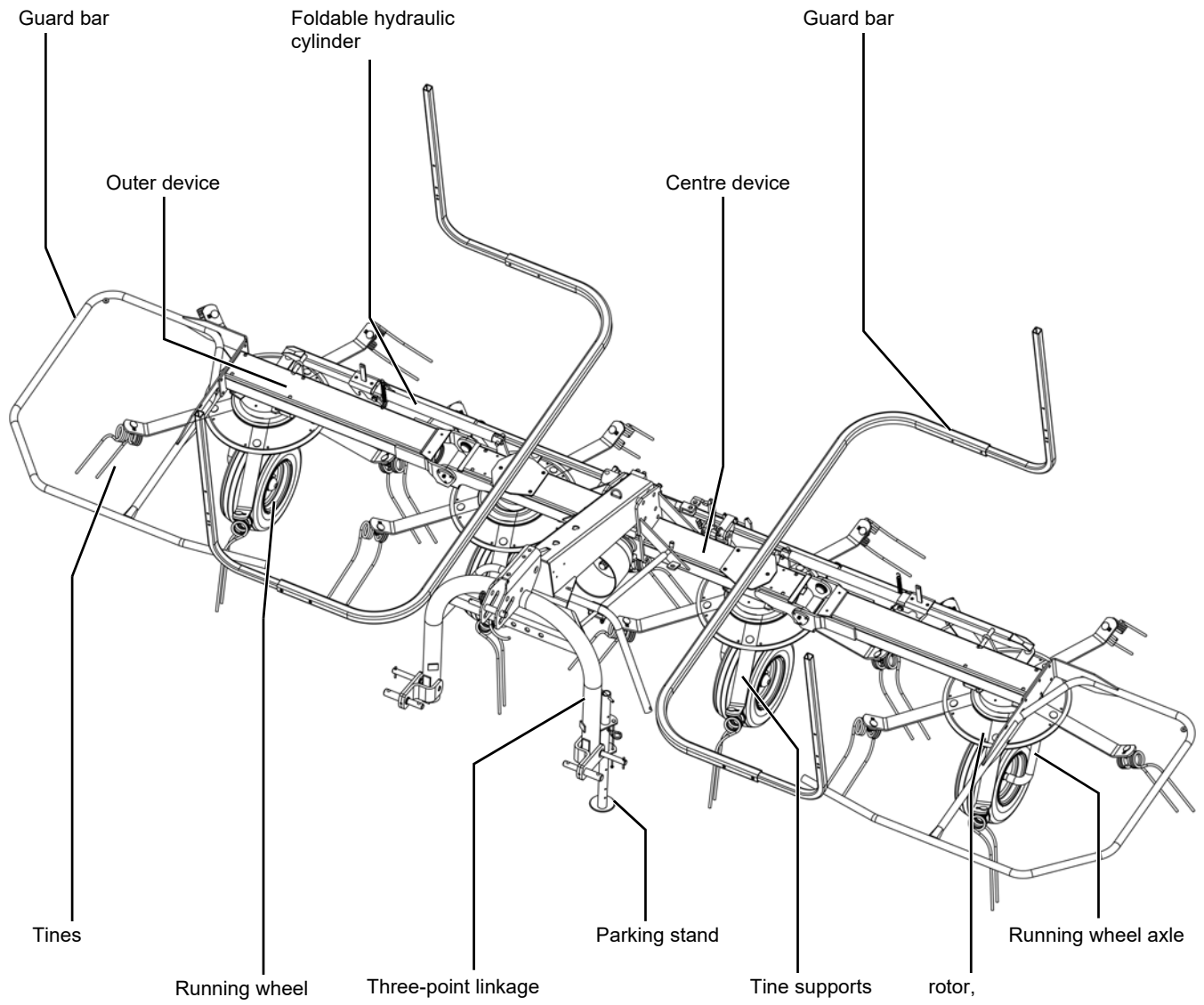

Getting to know the machine

Technical specifications

Dimensions

	Work position W (m)		Transport position T (m)	
	VF6590	VF6597	VF6590	VF6597
L = length	2.10			
L _L = length from the reflector	0.82			
W = width	5.00	5.40	2.80	2.90
H = height	1.70		2.40	2.60
W _O = clearing width	4.60	5.20	-	
G = Distance from the centre of gravity	0.90 m (2.95ft)		0.90 m (2.95ft)	

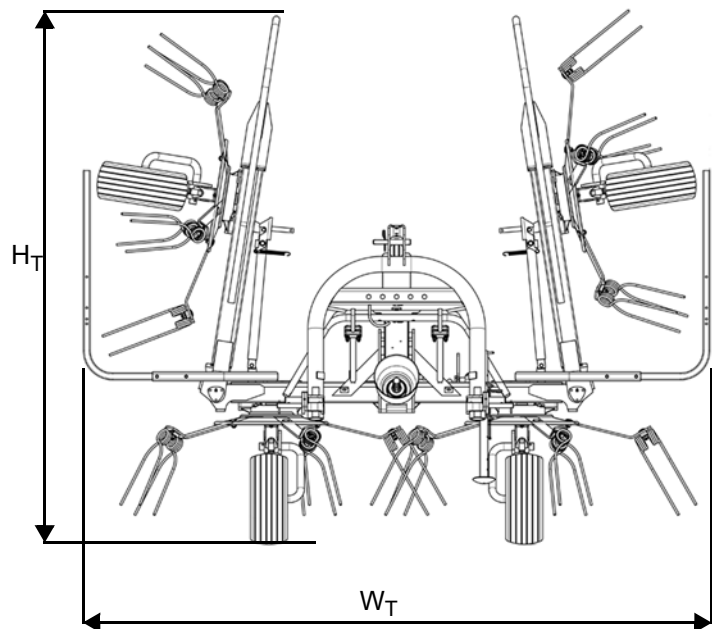
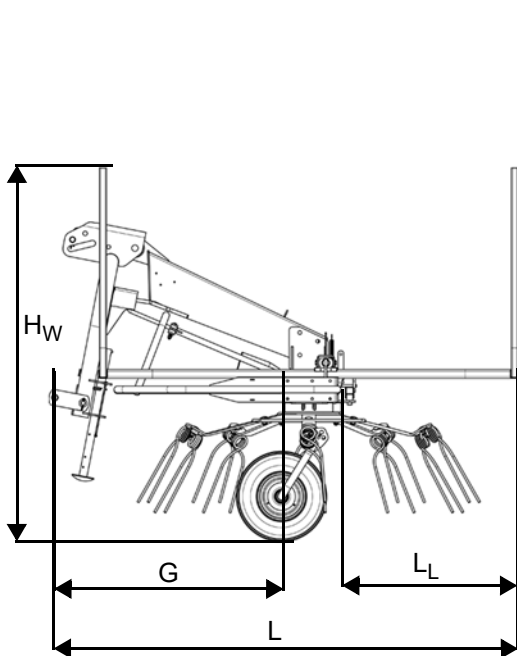
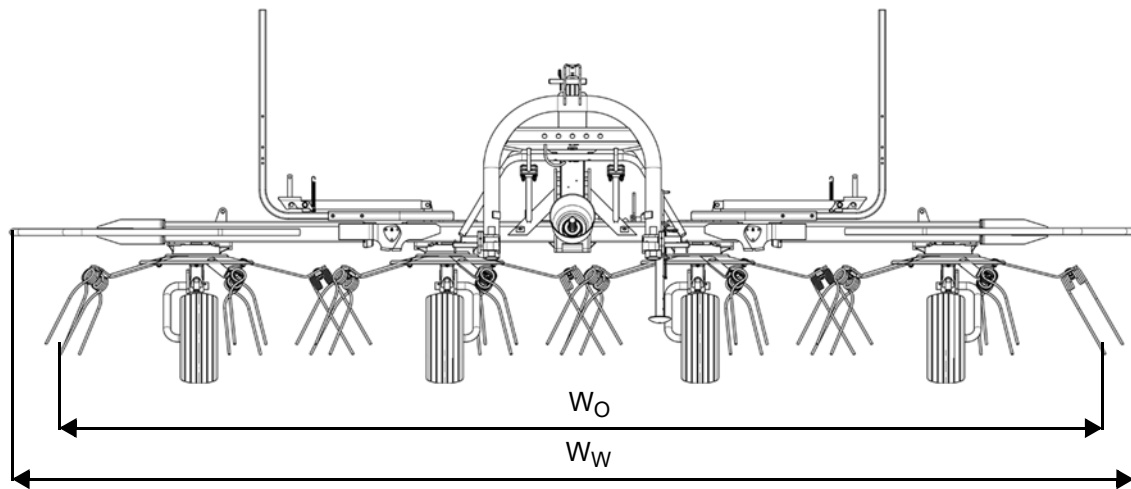

Weights

Weights		VF6590	VF6597
	Total weight	492 kg	520 kg
	Permitted supported load	60 kg	51 kg

Tractor equipment required

Output / connections

Getting to know the machine

	Minimum output of the tractor	32 kW (43 hp)
	Voltage supply for lighting equipment	12 V, 7-pin plug socket ISO 1724
	Hydraulic connections	1 x single-acting control device in addition: 1 x double-acting control device for optional hydraulic border tedding system [+]
	Hydraulic pressure	150 - 210 bar
	PTO shaft speed	max. 540 rpm
	Coupling device	Three-point lifting pickup

Machine equipment

Rotors/tine supports/tines		VF6590	VF6597
	Number of rotors	4	
	Number of tine supports per rotor	5	6
	Tine saver	[+]	
Wheels			
	Running wheel axles, side device	16 x 6.50	
Safety accessories			
	Lighting equipment	[+]	
	Warning signs	[+]	
PTO shaft			
	Standard PTO shaft		
Axles			
	Number of axles	4	
	Model	4 x rigid axle, adjustable	

Measurement of airborne sound emissions

The airborne sound emissions from the machine are below the levels stipulated by machinery directive 2006/42/EC.

- A-weighted sound level in the workplace:
< 70 dB(A)
- Currently C-weighted sound level:
< 63 Pa (130 dB based on 20 μ Pa)
- A-weighted sound level on the machine:
< 80 dB(A)

Delivery and assembly

Checking the scope of delivery

Delivery is in the fully assembled state

The machine is delivered fully assembled. Using the check list, check the loose parts on delivery. If any parts of the machine have not been fitted or are missing, please contact your dealer.



Do not assemble the machine yourself.

Trained personnel are required to assemble the machine. Do not perform assembly work yourself. The following points are required to be met for the machine to be in proper condition:

- Observance of a sequence of work steps.
- Compliance with tolerances and torques.
- Knowledge of work safety during assembly.

Incorrect assembly can result in damage to the machine or accidents.



If parts are missing or have been damaged during transportation, please inform the dealer, importer or manufacturer immediately.

Checklist for parts which were supplied loose	Quantity
Operator's manual	1
Spare part manual	1
PTO shaft	1
Special accessories	See delivery note

Operator's manual

The operator's manual and spare part manual can be found in the document box on the machine.

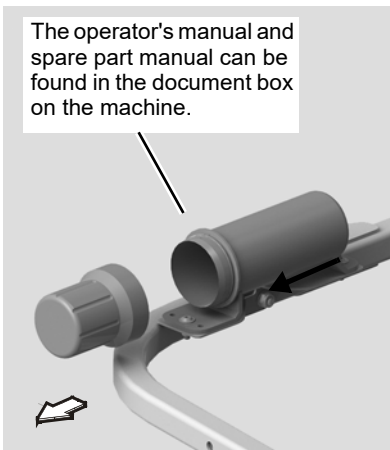

The operator's manual belongs with the machine and must always be kept on board. A document box for the operator's manual and spare part manual is mounted on the guard bar of the centre device.

Adapting the PTO shaft

The length of the PTO shaft was selected at the factory to suit almost all types of tractor. Only in exceptional cases is a correction of the PTO shaft length required on individual tractors. Check the length of the PTO shaft on each tractor prior to first use.

A manufacturer's operator's manual for the PTO shaft is enclosed. This includes detailed information on the relevant version of the PTO shaft and must be observed.

Safety



Switch off the tractor engine, put the parking brake in the park position, remove the ignition key and secure the tractor against rolling away

Before you dismount:

- ▶ Lower all implements to the ground.
- ▶ Switch all operating controls to their neutral or park position.
- ▶ Switch off the tractor engine, put the parking brake in the park position, remove the ignition key and secure the tractor against rolling away.



An unsecured tractor can run you over or trap you. Otherwise, serious or fatal injury may be caused as a result.



Correct length

A PTO shaft that is too long must not be used. Otherwise, damage to the drive bearings on the tractor and machine may be caused as a result.

Checking the length of the PTO shaft

- ▶ Couple the machine to the tractor without the PTO shaft.
- ▶ Lower the tractor's lower link.
- ▶ Set the combination (tractor and machine) to the smallest steering angle.
- ▶ Switch off the tractor engine, put the parking brake in the park position, remove the ignition key and secure the tractor against rolling away.



Delivery and assembly

Shortening the PTO shaft

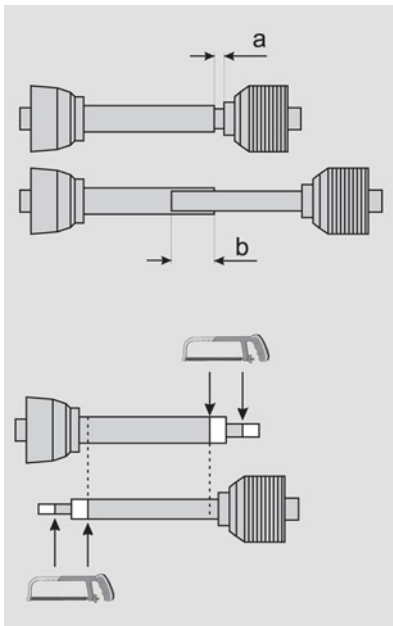

- ▶ Pull the PTO shaft apart and connect one half to the tractor PTO shaft drive and one to the machine and secure them.
- ▶ Place the two shaft halves next to each other and:
 - Check for a minimum of 250 mm (10 in) overlap (b).
 - Check that the PTO shaft does not block at one end (minimum clearance (a) = 20 mm (1 in))
- ▶ Shorten the slide tube and guard tube by the same dimension.
- ▶ Deburr the ends of the tubes.
- ▶ Remove the swarf.
- ▶ Grease the sliding surfaces well.

Fitting the PTO shaft

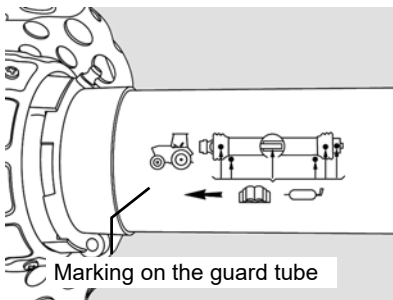

Make sure that you fit the PTO shaft in the correct installation position. There is a marking on the guard tube of the PTO shaft.

- ▶ Check the length of the PTO shaft and shorten it if necessary.
- ▶ Place the PTO shaft onto the PTO stub shaft of the machine.
- ▶ Secure the PTO shaft with a locking pin.

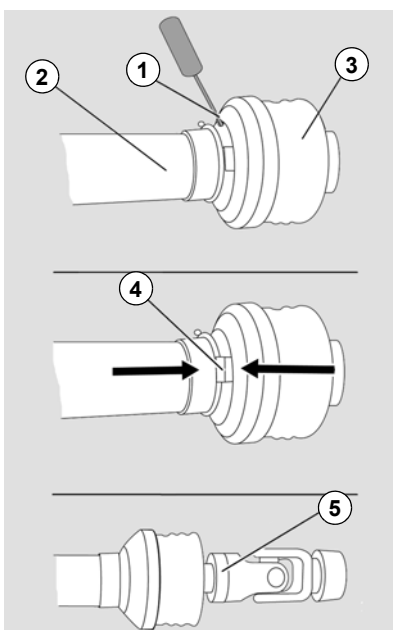

- ▶ Remove the locking screw (1) between the guard tube (2) and the guard cone (3).
- ▶ Twist the guard cone (3) and the guard tube (2) in opposite directions so that the "noses" of the slide ring (4) are positioned directly over the slots on the guard cone (3).
- ▶ Pull the guard cone (3) and guard tube (2) back until the single joint (5) is accessible.
- ▶ Connect the PTO shaft to the machine.
- ▶ Push the guard cone (3) and guard tube (2) back over the single joint (5).
- ▶ Tighten the locking screw (1).
- ▶ Secure the guard cone to the gear box using a jubilee clip.

Prepare the top link

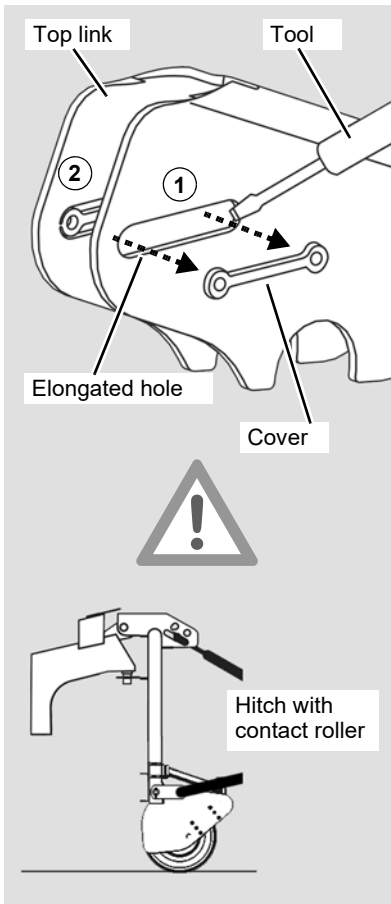

Only when using the optional contact roller: Remove the cover of the elongated hole from the top link of the three-point linkage.

Please note the following: Otherwise, damage to the machine may be caused as a result:

- **Only with the optional contact roller:**
 - ▶ Remove the cover of the elongated hole from both sides of the top link using an appropriate tool.
 - See adjacent illustration. Items (1) and (2).



Please ensure that, where an optional contact roller is used, the hitch pin for the upper link attachment is in the middle of the elongated hole when the machine is lowered. Otherwise, the machine may not be able to handle the unevenness of the ground.

Coupling the machine

Safety



Observe the safety information

Disregard for safety information can lead to serious or fatal injury. See chapter »Safety«, page 7.

Increased risk of injury

When the machine is being coupled to the tractor, there is an increased risk of injury. Therefore:

- Never stand between the tractor and machine.
- Secure the tractor against rolling away.
- Persons must not be present behind the machine under any circumstances.
- Actuate the three-point power lift system slowly and carefully.

Failure to observe these instructions can result in serious or fatal injury.

General

The following work steps are described in this section:

- »Coupling the three-point linkage«
- »Inserting the parking stand«
- »Coupling the PTO shaft«
- »Electrical connections«
- »Connecting the hydraulic couplings«

Adjusting the hitch

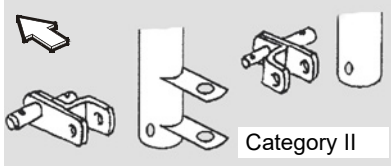
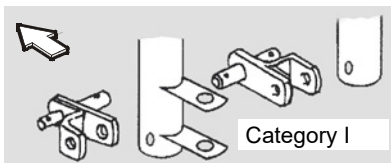

For use on category I tractors, proceed as follows:

- ▶ Remove the split pin on the first clevis of the 3-point trestle (see illustration).
- ▶ Turn the clevis round 180 degrees.
- ▶ Secure the clevis with a new split pin.
- ▶ Repeat the procedure for the second clevis.

Tractor with quick-release couplings

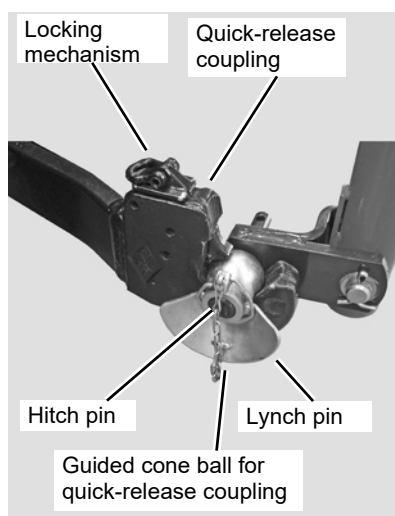

Follow the instructions for the quick-release coupling

Follow the instructions below for tractors with quick-release couplings. Also note the instructions and warnings in the operator's manual of the tractor manufacturer. If this requirement is ignored, the consequence may be damage to the machine and even life-threatening injuries.

- ▶ Slide guided cone balls for the quick-release coupling that are suitable for the tractor onto the hitch pins of the machine.
- ▶ Secure the guided cone balls for the quick-release coupling with lynch pins.
- ▶ To couple the machine, raise the lower link (rear power lift system) until the locking mechanism for the quick-release coupling locks in place.
- ▶ Follow the instructions for »Coupling the three-point linkage«, page 35.

Coupling the three-point linkage

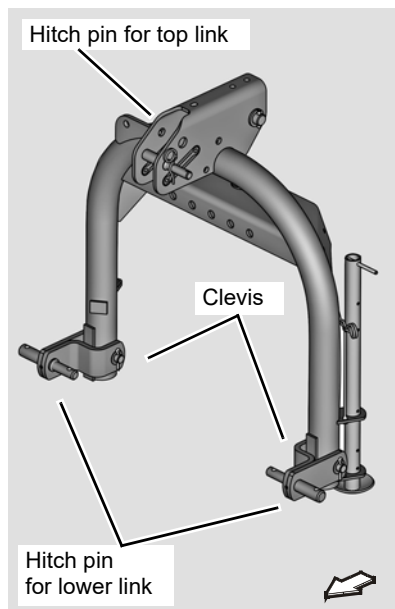

The machine is equipped ex-factory for coupling to the tractor's three-point lifting pick-up.

- ▶ Reverse the tractor with lower links lowered until the hooks on the lower link are below the machine's hitch pins.
- ▶ Using the hydraulic control device, raise the lower link until the arrester hooks on the lower link engage with the hitch pins.
- ▶ Secure hitch pins for lower link.
- ▶ Adjust the tractor's top link to the required length and connect to the top link hitch pin.
→ See »Coupling the top link«, page 36.
- ▶ Secure hitch pins for top link.



Note the instructions and warnings in the operator's manual of the tractor manufacturer for tractors with lower link quick-release couplings.

Coupling the machine

Coupling the top link

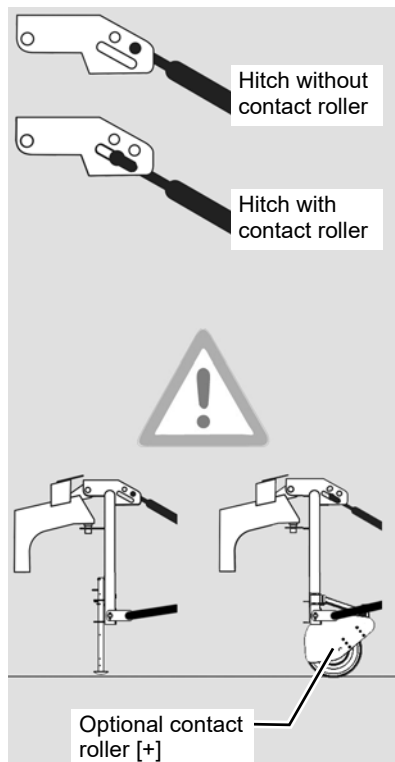

Fit the hitch pins correctly

When coupling the top link, ensure that the hitch pin is correctly fitted (see adjacent illustration). Otherwise, damage to the machine may be caused as a result.

- **With optional contact roller:**

- ▶ Remove the cover of the elongated hole from both sides of the top link using an appropriate tool.

- See »Prepare the top link«, page 33.

- ▶ Insert the hitch pin for the top link in the elongated hole and secure using a safety splint.

- ▶ Lock the transport locking device for road transport.

- See »Locking the contact roller [+] transport locking device«, page 49.

- **Without contact roller:**

- ▶ Insert the hitch pin for the top link into the hole and secure using a safety splint.

- ▶ Adjust the tractor's top link to the required length and connect to the top link hitch pin.

- ▶ Secure the top link hitch pin using a safety splint.

- ▶ Adjust the lower link such that a uniform ground clearance is maintained.



Please ensure that, where an optional contact roller is used, the hitch pin for the upper link attachment is in the middle of the elongated hole when the machine is lowered. Otherwise, the machine may not be able to handle the unevenness of the ground.

Inserting the parking stand

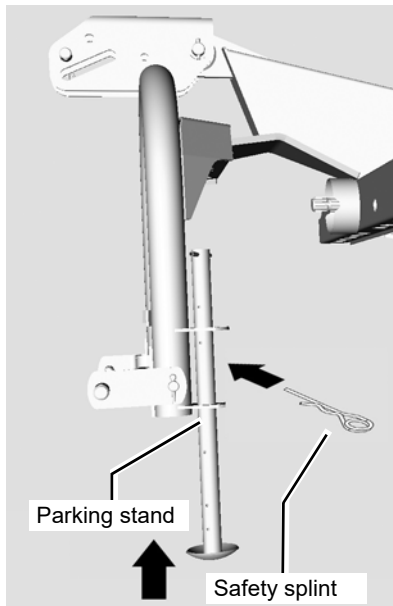

Secure the machine with a parking stand

In the transport position, the parking stand must be used to secure the machine when coupling, uncoupling, parking and storing. The machine could be damaged and serious or fatal injuries could be caused.

After coupling, insert the parking stand.



- ▶ Switch off the tractor engine, put the parking brake in the park position, remove the ignition key and secure the tractor against rolling away.
- ▶ Pull out the safety splint from the parking stand.
- ▶ Insert the parking stand.
- ▶ Secure the parking stand with the safety splint.

Coupling the machine

Coupling the PTO shaft

Make sure that you fit the PTO shaft in the correct installation position. There is a marking on the guard tube of the PTO shaft.

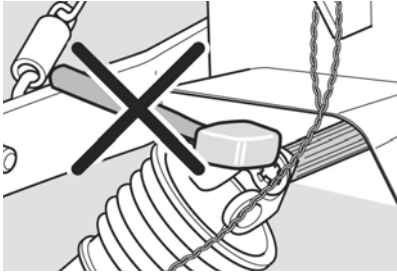

Do not use force

When coupling the PTO shaft, do not use a hammer or any similar tools. Using these types of tool can severely damage the PTO shaft. Otherwise, damage to the machine may be caused as a result.

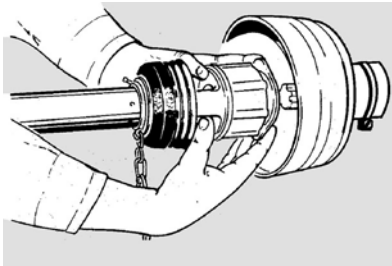

When coupling the PTO shaft, make sure it is in the correct position.

- ▶ Check whether the PTO shaft must be shortened before coupling.
- ▶ Shorten the PTO shaft if necessary.
 - See chapter »Delivery and assembly«, section »Adapting the PTO shaft«, page 31
- ▶ Check that the tractor's PTO stub shaft is clean and lubricated.
- ▶ Couple the PTO shaft to the tractor and the machine.
- ▶ Ensure that the PTO shaft is engaged on the shaft ends.
- ▶ Secure the guard tubes so that they cannot rotate at the same time.
- ▶ Couple the single joint with slip clutch to the machine's PTO stub shaft.

Connections

Electrical connections



Checking the electrical cables

Check the electrical cables. The electrical cables must not chafe or hang loose. Electrical cables that have been torn away or worn through must be replaced. Otherwise, damage to the machine may be caused as a result.

Lighting equipment [+]



The lighting equipment is available as additional equipment from your dealer.

- ▶ Connect the plug for the 12 V power supply to the 7-pin plug socket on the tractor.

ISO 1724 plug arrangement



A connection in accordance with ISO 1724 must be present on the tractor. If your tractor does not have the corresponding connection, a corresponding connection must be retrofitted. Consult your dealer.

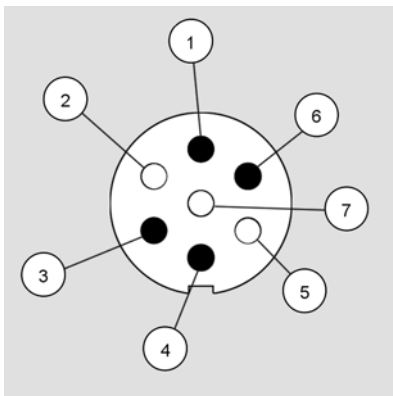

PIN	Cable	Connection to
1	Yellow	Left-hand indicator (amber)
2		Not used
3	White	Earth; all lights
4	Green	Right-hand indicator (amber)
5	Brown	Right rear light (red)/right position light (white)
6	Red	Brake lights
7	Black	Left rear light (red)/left position light (white)

Connecting hydraulics



Check hoses and couplings

Check all hydraulic hoses for damage before connecting them. Check all hydraulic couplings for firm seating after connecting them. Defective hydraulic hoses and poorly fitting hydraulic connections can trigger unpredictable movements of the machine, causing severe damage to the machine as well as personal injury. Serious or fatal injury may be caused as a result.

Secure the tractor's control devices

In the transport position, secure the control devices on the tractor against unintended actuation and lock them if possible. Unintentional activation of a control device can trigger unpredictable movements of the machine and cause serious machine damage and personal injury. Serious or fatal injury may be caused as a result.

Check the routing of the hydraulic hoses

Close or disconnect the quick couplings with great care. Remove any dirt or air which has entered the hydraulic system. The hydraulic system may otherwise be seriously damaged. Material damage or personal injury may be caused as a result.

Avoid mixing oils

If the machine is used on different tractors, an impermissible mixing of oil may occur. Impermissible oil mixtures can irreparably damage tractor components.

Connecting the hydraulic couplings



Make sure the connection is correct

Ensure that the hydraulic system is connected correctly. Otherwise, injuries and damage to the machine may be caused as a result.

Hydraulic connection at zero pressure only

Work must only be performed on the hydraulic system if the tractor and machine hydraulic system is at zero pressure. A pressurised hydraulic system can trigger unpredictable movements of the machine and can cause serious machine damage and personal injury. Serious or fatal injury may be caused as a result.



- ▶ Close the ball valve.
- ▶ Set the tractor hydraulics to "free float".



- ▶ Switch off the tractor engine, put the parking brake in the park position, remove the ignition key and secure the tractor against rolling away.
- ▶ Roll up the control ropes and store them in the tractor cab.

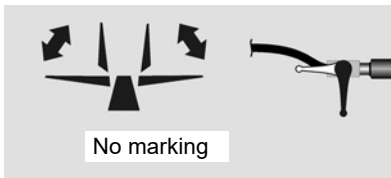

The tractor's single-acting hydraulic control device provides the means by which the rotors are raised and lowered.



- ▶ Close the ball valve.



- ▶ Set the tractor hydraulics to floating position.



- ▶ Switch off the tractor and secure it.

- ▶ Connect the machine's hydraulic coupling to the single-acting control device.
- ▶ Roll up the control ropes and store them in the tractor cab.

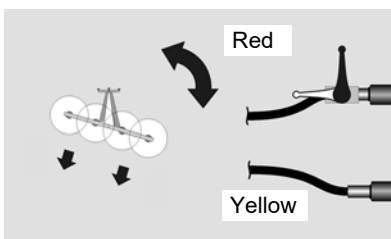

The optional hydraulic border tedding system [+] is controlled using the tractor's double-acting hydraulic control device.

- ▶ Connect the hydraulic coupling on the machine to the double-acting control device.

Hydraulic line	Marking
Pressure line	Red
Return line	Yellow

Safety

The following applies to all preparations for operation:



Observe the safety information

Disregard for safety information can lead to serious or fatal injury. See chapter »Safety«, page 7.

Secure the machine

Secure the machine against accidental starting and rolling away. Use wheel chocks. The machine must stand on a level, firm and secure surface and be supported during the work, if necessary. Unsecured or non-supported machines can cause accidents. Serious or fatal injury may be caused as a result.

No persons in the working area

Ensure that no persons – children in particular – are present in the slewing and working area of the machine. Persons could be caught by the machine within this area. This could result in fatal injury.

Avoid the hazard area

The rotors are considered a hazard area. Do not stand in the hazard area. The rotors may lower or turn. Serious or fatal injury may be caused as a result.

Unfold fully and evenly

Ensure that the side devices are evenly unfolded. If there is a malfunction, fold the side devices back in and repeat the process at a higher engine speed. The hydraulic cylinders must be completely extended in the work position. Otherwise, damage to the machine may be caused as a result.

General

The following applies when performing all adjustment work:

- ▶ Check the tyre pressures.
- ▶ Secure the machine.
- ▶ Lower the machine to the work position.
- ▶ Undo appropriate bolts and/or screws.
- ▶ Make the required adjustment.
- ▶ Retighten the bolts.

The following work steps are described in this section:

- Fold the machine into its work position.
- Adjust working depth.
- Adjust rotor pitch.
- Adjust tine support.

Folding the machine into the work position



Observe the contour of the terrain

Move the machine onto a flat surface or uphill before changing from the transport to the work position. Avoid inclines on which the combination (tractor and machine) could slip or overturn. The side device can swivel out uncontrollably. Otherwise, damage to the machine may be caused as a result. There is an increased risk of tipping and injury in a position at right angles to the direction of the slope.

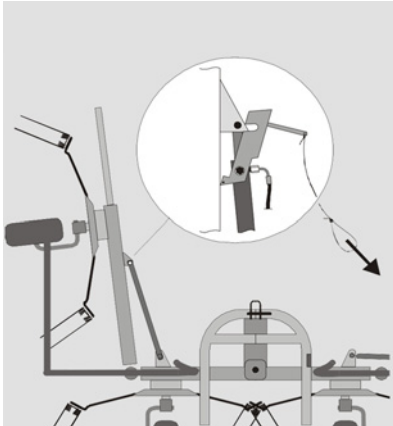

- ▶ Swivel in the parking stand.
→ See »Inserting the parking stand«, page 37.
- ▶ Switch on the tractor.
- ▶ Fully lower the machine using the 3-point lift support.
- ▶ Tighten the rope for the transport locking device.
- ▶ Using the hydraulic control device, fold the machine into its work position.

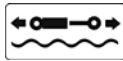
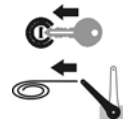

- ▶ For optimum adaptation to ground contours, activate the floating position of the tractor's hydraulic control device.

Adjusting the working depth

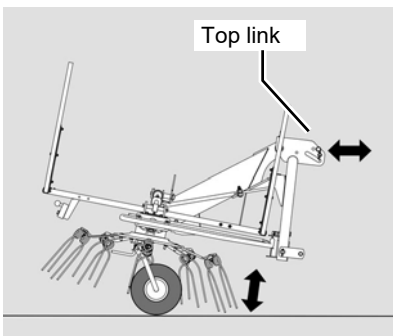

In work position, the distance between the tines and the ground is adjusted via the tractor's top link.



- ▶ Switch off the tractor PTO shaft drive.
- ▶ Using the hydraulic control device, fold the machine into its work position.
- ▶ Align the running wheels by driving forwards.
- ▶ Switch off the tractor engine, put the parking brake in the park position, remove the ignition key and secure the tractor against rolling away.
- ▶ Adjust the top link to the required length so the distance between the tines and the ground can be adapted.



The tines should lightly touch the ground.

Preparing for operation

Adjusting the rotor pitch



Secure the machine

Secure the machine against inadvertent starting and rolling. The machine must be standing on firm and level ground and, if necessary, be supported during the work. Unsecured or non-supported machines can cause accidents.

Never work under the rotors

Do not carry out work under suspended loads (for example, raised rotors) unless the loads have been secured. Carry out the work only from the outside and between the tine arms. Otherwise, serious injury may be caused as a result.

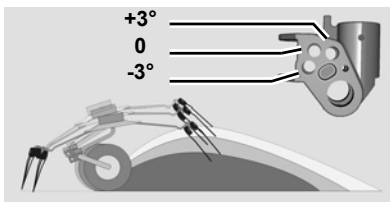
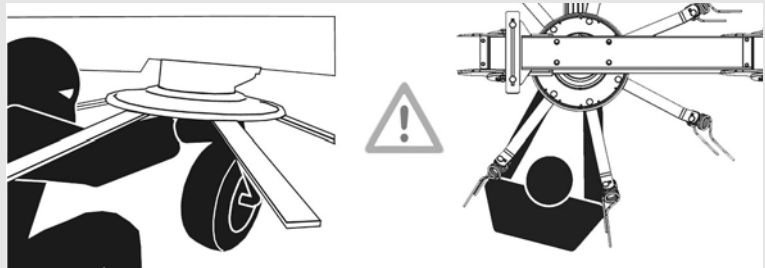

The rotor pitch changes the tedding angle. It thereby adjusts how far the crop is ejected to the rear. The tedding angle can be adjusted in steps of 3°.



- ▶ Switch off the tractor PTO shaft drive.
- ▶ Using the hydraulic control device, fold the machine into its work position.
- ▶ Align the running wheels by driving forwards.
- ▶ Using the tractor's 3-point lift support, raise the machine by approximately 30 cm (11.82 in).
- ▶ Lock the tractor's hydraulic control device.



- ▶ Switch off the tractor engine, put the parking brake in the park position, remove the ignition key and secure the tractor against rolling away.

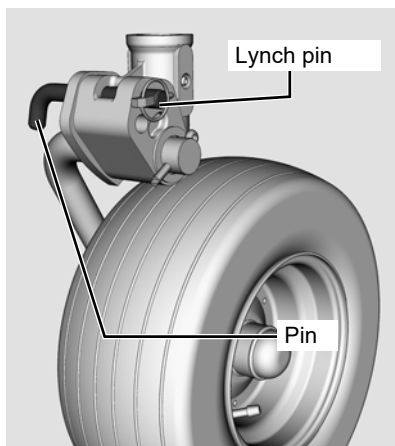

- ▶ Release the lynch pin on all rotor chassis.
- ▶ Move running wheel axle into new position.
- ▶ Insert bolt and secure with lynch pin.



Adjust all wheels uniformly. Flat rotor pitch results in optimised crop pickup.

Adjusting tine supports

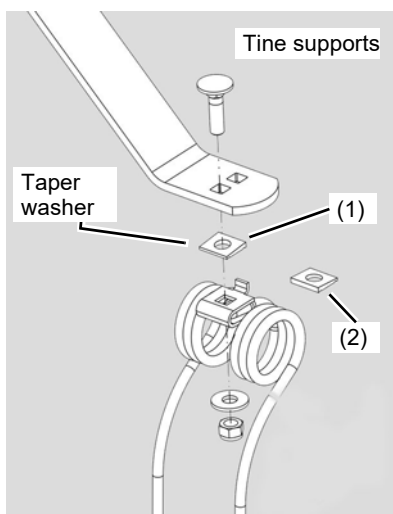
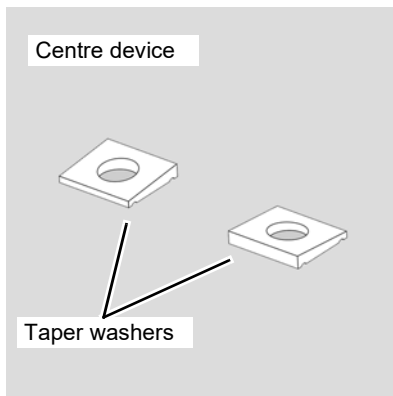

The ejection angle of the spring tines is adjusted by means of taper washers. This function enables consistent, uniform and optimum work results. The smaller the angle, the steeper and stronger the tine position.

- ▶ The taper washers are part of the scope of delivery and are supplied in a separate bag.

- ▶ Attach taper washers to tine supports.
 - Angle of tine position (1): gentle (4°).
 - Angle of tines without taper washer: normal (0°).
 - Angle of tine position (2): aggressive (-4°).

Safety

Before transporting the machine on public roads, please read the following safety information. Compliance is mandatory and will help you to avoid accidents.



Observe the safety information

Disregard for safety information can lead to serious or fatal injury. See chapter »Safety«, page 7.

Ensuring road safety

The machine must conform to current national traffic regulations if you intend to drive with it on public roads. Ensure the following:

- Lighting, warning and protective equipment must be fitted.
- The permissible transport widths and weights, axle loads, tyre load-bearing capacities, laden weights and national speed restrictions must be complied with.
- The maximum permissible road transport speed must be complied with, but not exceed 50 km/h (30 mph).
- Before driving on public roads, fold in all guard bars and rotors and secure the machine.
- The machine should only be towed by agricultural or forestry tractors.
- The empty weight of the tractor must be greater than the weight of the machine.

The driver and keeper of the vehicle are liable should these conditions not be observed.

Observe transport width

Observe the permissible transport widths. Put the machine in the transport position and attach lights, warning signs and protective equipment. The driver and keeper of the vehicle are liable for any non-compliance with national traffic regulations.



Observe the contour of the terrain

Move the machine onto ground that is as flat as possible before changing from the work position to the transport position. Avoid inclines on which the combination (tractor and machine) could slip or overturn. There is an increased risk of tipping and injury in a position at right angles to the direction of the slope.

Border tedding system off

Ensure that the border tedding system is not activated when changing to the transport position. Otherwise, the machine may be damaged.

General

The following work steps are described in this section:

- »Prior to road transport«
- »Folding the machine into the transport position«
- Secure the machine

Prior to road transport

When driving on public roads, the machine must be in the transport position.



Clean the machine before travelling on the road

Before travelling on the road, remove all coarse dirt, crop residues and clods of earth from the machine and clean it. Crops or dirt that drop onto the road can cause slippery road conditions. This can result in traffic accidents and accidents causing serious or fatal injuries.

Clean lighting equipment before travelling on the road

All lighting equipment must be cleaned before road transport. Crop residue or dirt may cover up the lighting equipment and adversely affect its correct operation. This can result in traffic accidents and accidents causing serious or fatal injuries.

Fold up the machine completely

Ensure that the machine is always completely folded up. Never drive with a partially folded side device. This could lead to accidents and personal injury.

To prepare the machine for road transport, carry out the following steps:

- ▶ Remove any crop and coarse dirt.
- ▶ Fold up the machine completely.
- ▶ Lock the contact roller [+] transport locking device.
- ▶ Attach the lighting equipment/warning signs.
- ▶ Raise the machine to transport height.

Folding the machine into the transport position



Make sure the machine is standing level

Before changing from the transport to the work position (and vice versa), make sure the machine is standing level. The machine could tip over, particularly on hillside locations. The machine could be damaged and serious or fatal injuries could be caused.

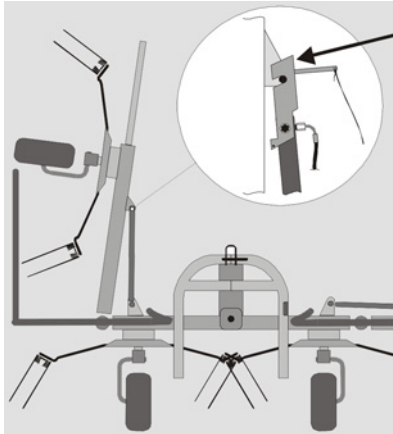

▶ Switch off the tractor PTO shaft drive.

▶ Move the machine into its transport position via the tractor's single-acting control device until the transport locking device engages.



▶ Close the ball valve.

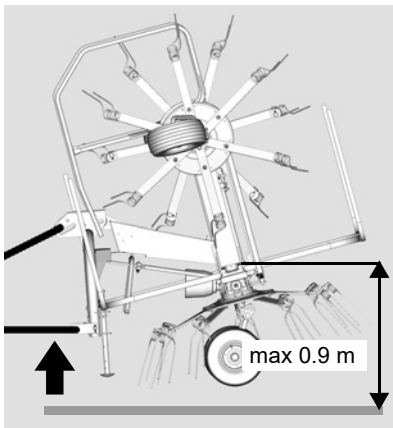

▶ Raise the tractor's lower link until it reaches the transport position.



Do not raise the machine beyond the maximum permitted reflector height.

Locking the contact roller [+] transport locking device

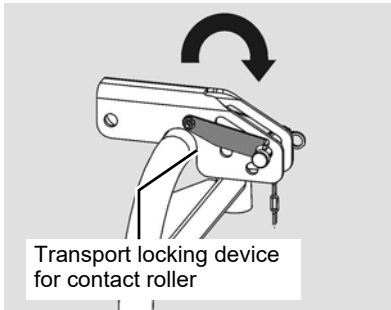

Lock the transport locking device

When transporting a raised machine, the transport locking device must be locked. Otherwise, damage to the machine may be caused as a result.

For the optional contact roller [+], secure the transport locking device for the top link hitch pin.

- ▶ Move the machine into its transport position.
- ▶ Lock the contact roller transport locking device.



- ▶ Remove the transport locking device for the contact roller when putting the machine into operation. Otherwise, damage to the machine may be caused as a result.

Road transport



Follow the instructions below for road transport. This could cause traffic accidents and accidents with fatal consequences.

- ▶ Before pulling away, check the immediate vicinity. Always make sure that you have a clear field of vision and, in particular, look out for children within the operating area of the machine.
- ▶ When the vehicle is in motion, lock the control devices on tractor.
- ▶ Do not transport people or objects on the machine.
- ▶ Adjust your speed to road conditions.
- ▶ Do not exceed a maximum speed of 50 km/h. Comply with the national speed limits.
- ▶ Ensure sufficient steering and braking capability. Driving characteristics, steering, and braking capability are all influenced if the machine is coupled (increased braking distance as a result of greater inertia).
- ▶ There is a danger of tipping on slopes and if corners are taken too fast.

Checking the machine



Prior to driving on the road, check the machine against the check list:

- Tractor's PTO shaft drive is "OFF"?
- Side devices completely folded in?
- Tractor control system for hydraulics is "OFF"?
- Lower link engaged and secured at the sides?
- Machine in transport position?
- Transport locking device for the optional contact roller [+] locked?
- Parking support and parking stand secured in the transport holder?
- Crop residues and dirt removed?
- Lighting cable routed so that it is not strained and cannot become caught in the tractor's wheels when cornering?
- Lighting equipment in good working order?

Safety

The following applies for all preparations on the field:



Observe the safety information

Disregard for safety information can lead to serious or fatal injury. See chapter »Safety«, page 7.

Switch off the tractor and secure it

Before you dismount:

- ▶ Switch off the PTO shaft drive.
- ▶ Lower all implements to the ground.
- ▶ Switch all operating controls to their neutral or park position.
- ▶ Put the tractor's parking brake into the park position.
- ▶ Switch off the tractor.
- ▶ Remove the ignition key.
- ▶ Secure the tractor against rolling away.

An unsecured tractor can run you over or trap you. Serious or fatal injury may be caused as a result.

Avoid the hazard area

The rotors are considered a hazard area. Do not stand in the hazard area. The rotors may lower or turn. Serious or fatal injury may be caused as a result.

Secure the machine

Secure the machine against accidental starting and rolling away. Use wheel chocks. The machine must stand on a level, firm and secure surface and be supported during the work, if necessary. Unsecured or non-supported machines can cause accidents. Serious or fatal injury may be caused as a result.

No persons in the working area

Ensure that no persons – children in particular – are present in the slewing and working area of the machine. Persons could be caught by the machine within this area. Serious or fatal injury may be caused as a result.

Observe the slewing process

Observe the rotors during the slewing process. If the machine behaves unusually during the process, stop immediately to avoid damage.

Preparations on the field

General

The following work steps are described in this section:

- »Folding the machine into the work position«

Folding the machine into the work position



Make sure the machine is standing level

Before folding the machine out, check that it is standing level. The machine could tip over, particularly on hillside locations. This could lead to damage to the machine and personal injury.

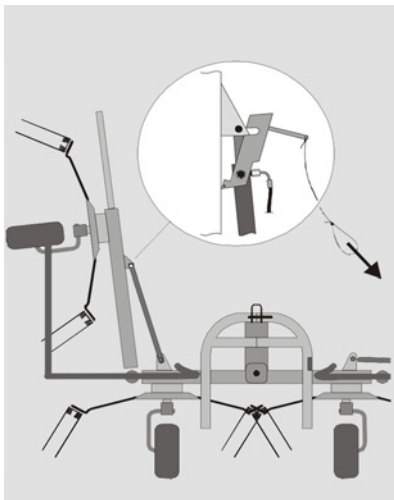

After road transport, the machine is brought into the work position on the field. Follow the handling instructions below:

- ▶ Folding the machine into the work position
 - See »Folding the machine into the work position«, page 43.

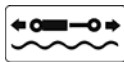

- ▶ For optimum adaptation to ground contours, activate the floating position of the tractor's hydraulic control device.

Unlocking the contact roller [+] transport locking device

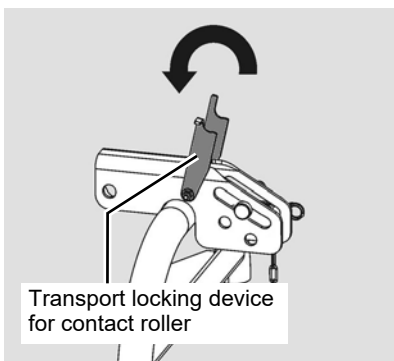

For the optional contact roller [+], unlock the transport locking device for use. Otherwise, damage to the machine may be caused as a result.

- ▶ Unlock the contact roller transport locking device.



In the work position, the top link pin must be fitted centrally in the elongated hole, so that the machine is able to adapt to the unevenness of the ground.

Safety

**Observe the safety information**

Disregard for safety information can lead to serious or fatal injury. See chapter »Safety«, page 7.

No riding on the machine

Persons or objects must never be transported on the machine. Carrying passengers – particularly children – on the machine is life-threatening and prohibited. Serious or fatal injury may be caused as a result.

No persons in the working area

Ensure that no persons – children in particular – are present in the slewing and working area of the machine. Persons could be caught by the machine within this area. Fatal injury may be caused as a result.

Maximum PTO shaft speed 540 rpm

The PTO shaft speed must not exceed 540 rpm and must be adapted to the condition of the crop. Higher revolution rates can cause damage to the machine.

Only allow the PTO shaft clutch to respond for a short time

Do not allow the slip clutch to respond for longer than 3 seconds. If the clutch responds for a prolonged period, it will become worn and the disconnect torque will drop.

Do not compress the PTO shaft

The PTO shaft between the tractor and machine must not be compressed when in the work position or transport position. If compressed, PTO shafts can cause damage to the machine and tractor.

Observe the contour of the terrain

Pay even more attention when driving on an incline. Avoid inclines on which the combination (tractor and machine) could slip or overturn. There is an increased risk of tipping and injury in a position at right angles to the direction of the slope.

Changes in the centre of gravity

When in work position, the machine's centre of gravity changes. Pay even more attention when driving on an incline. Avoid inclines on which the combination (tractor and machine) could slip or overturn. There is an increased risk of tipping and injury in a position at right angles to the direction of the slope.

Operation

General

The following methods of crop processing are possible with the rotary tedder:

- Tedding
- Turning
- Night swath laying (with swathing gear [+]).
- Swath laying
- Night swath turning (with swathing gear [+]).

Crop processing

The following methods of crop deposit are possible with this machine:

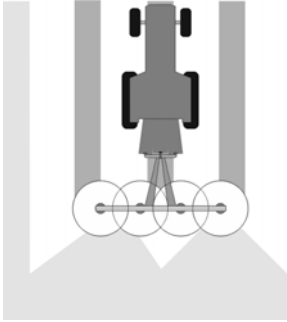
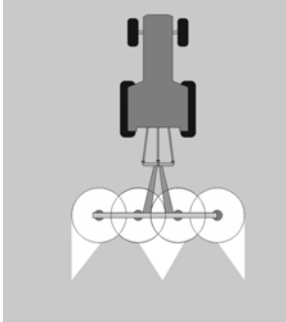
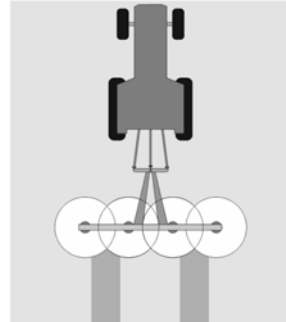
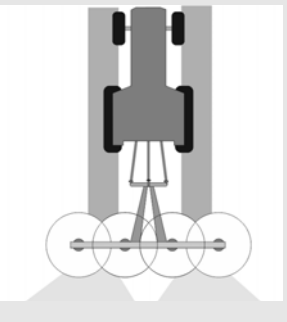
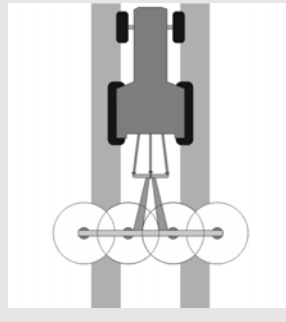
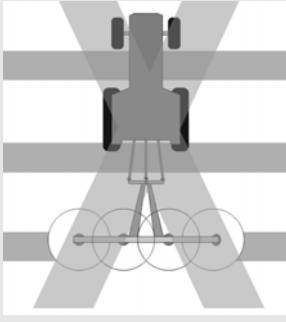
Tedding	Turning	Night swath laying
		
<p>When tedding, the freshly cut crop is distributed over the stubble.</p> <ul style="list-style-type: none"> ▶ Run the PTO stub shaft at roughly 500 rpm. 	<p>Turning ensures uniform drying of the crop after cutting.</p> <ul style="list-style-type: none"> ▶ Run the PTO stub shaft at roughly 400 rpm. 	<p>Swathing arranges the distributed crop in small swathes.</p> <ul style="list-style-type: none"> ▶ Fit the swathing gear. ▶ Run the PTO stub shaft at maximum 300 to 400 rpm.
Swath laying	Swath turning	Prevent crossing swathes
		
<p>Swath laying disperses the available swath to allow it to dry better.</p>	<p>For uniform drying, use swath turning.</p>	<p>Swathes should not be crossed. This puts uneven loads on the machine.</p>



Night swathing is possible only with the use of an additional swathing gear.

→ »Night swath gear box«, page 75

- ▶ Night swath laying: Work at max. 540 rpm.
- ▶ Night swathes can be tedded again by turning.

Using the machine



No persons in the working area

Ensure that no persons – children in particular – are present in the slewing and working area of the machine. Persons could be caught by the machine within this area. Fatal injury may be caused as a result.

Requirements

The machine is set correctly as follows:

- Working depth correctly adjusted.
- Tines correctly adjusted.
- Machine in work position.

Start work as follows:



- ▶ Switch on the tractor.

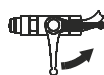

Open the ball valve.



- ▶ Set the single-acting hydraulic control device on the tractor to the floating position.
- ▶ Check that there is nobody in the working area of the machine.

Tractor PTO shaft drive



- ▶ Switch on the PTO shaft drive at a low engine speed.
- ▶ Slowly increase the speed. Do not exceed the maximum speed of 540 rpm.
- ▶ Select a driving speed at which the crop is picked up cleanly and distributed evenly.



Select a PTO stub shaft speed depending on crop processing requirements.

Operation

Working speed

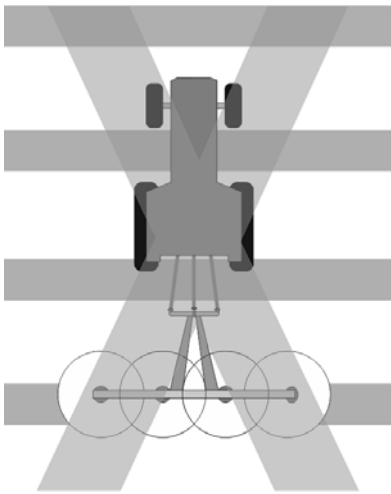

Avoid crossing over swaths

As a general rule, avoid crossing over swaths. The crop is distributed unevenly and the machine is subjected to abrupt stresses. Otherwise, damage to the machine may be caused as a result.

Allow ample space when driving around obstacles

Obstacles must be circumnavigated in good time and at a distance. Due to the width and length of the implement being towed, the machine reacts slowly and has an afterrun. Otherwise, damage to the machine may be caused as a result.

A constant working speed is essential for uniform crop processing. The working speed should be set between 4 and 8 km/h. The working speed depends on ground and crop conditions.

- ▶ Select a working speed at which the crop is picked up cleanly and completely.

Distribution

Depending on the crop, distribution is changed via the following settings:

- the rotor pitch
- the PTO stub shaft speed
- the working speed

Rotor pitch

- A steep inclination is ideal for tedding.
- A low inclination is ideal for almost dry and short crop and for improved pickup if the stubble is short.
→ »Adjusting the rotor pitch«, page 44

PTO shaft speed



- Too high a PTO shaft speed results in shatter losses and swath formation if the crop is dry.
- Too low a speed produces swath formation.

Working speed

- Fast working speed results in uneven distribution and heaps.

Border tending

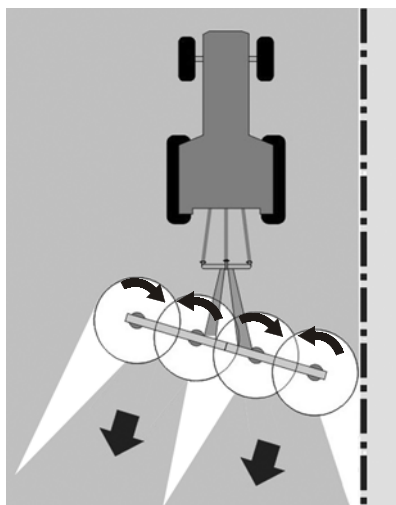

Watch for obstacles

When driving around obstacles or along fences ensure a sufficient distance is kept. A collision may cause damage to the machine.

Take care when cornering in the border tending position

Note the limited curve radius in the border tending position. A curve radius which is too tight can cause damage to the machine.

Pay attention to ground quality

Pay attention to ground quality, particularly when tending borders. The guidelines for turning on downhill terrain must be observed without fail. On an incline, the tractor and machine could tip over. This could result in personal injury and damage to the machine.

The machine can be mechanically tilted to the left or to the right with the border tending system. During border tending, the machine will trail behind the tractor at an angle. The crop is not spread beyond the field edge.

Mechanical border tending system

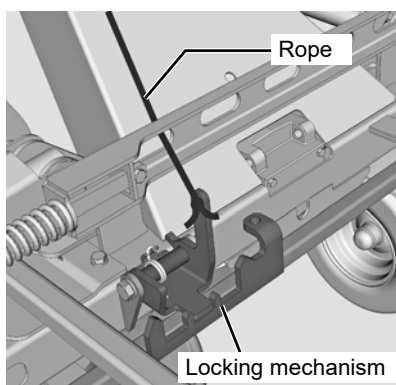

Adjusting border tending:

- ▶ Pull the rope on the border tending system and keep the rope tensioned.
- ▶ Slowly drive the tractor forwards and turn the running wheels in the desired direction.
- ▶ Release the border tending system rope so that the locking mechanism can engage.

Ending border tending:

- ▶ Pull the rope on the border tending system and keep the rope tensioned.
- ▶ Slowly drive the tractor forwards and straighten up the running wheels.
- ▶ Release the border tending system rope so that the locking mechanism can engage.

Hydraulic border tending system [+]



Removing the latch

When fitting the optional hydraulic border tending system [+], make sure that you remove the latch for the mechanical border tending system. Otherwise, damage to the machine may be caused as a result.

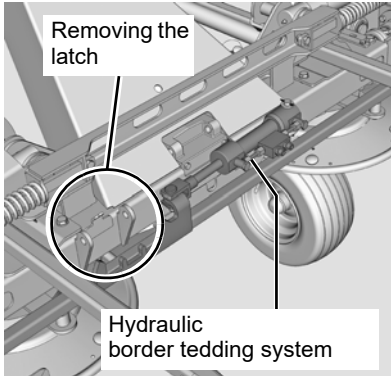

Proceed as follows with the optional hydraulic border tending system:

- ▶ Slowly drive the tractor forwards.
- ▶ Use the tractor's double-acting hydraulic control device to move the machine to the desired angled position.

Ending border tending:

- ▶ Slowly drive the tractor forwards.
- ▶ Straighten up the running wheels using the tractor's double-acting hydraulic control device.

Working in the border tending position



Watch for obstacles

When driving around obstacles or along fences ensure a sufficient distance is kept. A collision may cause damage to the machine.

Take care when cornering in the border tending position

Note the limited curve radius in the border tending position. A curve radius which is too tight can cause damage to the machine.



- ▶ Switch on the PTO shaft drive at a low engine speed.
- ▶ Slowly increase the speed. Do not exceed the maximum speed of 540 rpm.
- ▶ Select a driving speed at which the crop is picked up cleanly and distributed evenly.

Safety

The following applies to all cleaning and care work:



Observe the safety information

Disregard for safety information can lead to serious or fatal injury. See chapter »Safety«, page 7.



Secure the machine

- Switch off the PTO shaft drive.
- Depressurise the hydraulic system.
- Whenever possible, uncouple the tractor.
- Switch all operating controls to their neutral or park position.
- Put the tractor's parking brake into the park position.
- Switch off the tractor and remove the ignition key.
- Ensure the machine is standing on firm, secure and level ground, and provide additional support, if necessary.
- Secure the machine against rolling away.



Only if these regulations are observed can safe working be ensured during care and maintenance work. Unsecured or non-supported machines can cause accidents.

No persons in the working area

Ensure that no persons – children in particular – are present in the slewing and working area of the machine. Persons could be caught by the machine within this area. Fatal injury may be caused as a result.

Do not clean bearings or hydraulic parts with high-pressure cleaners

Do not clean bearings or hydraulic parts with high pressure cleaners. The high-pressure cleaner removes the grease film from the bare metal surfaces. Metal surfaces treated in this way can corrode. After each cleaning procedure, lubricate the bearing points and grease uncoated parts.

Clean the bearings and hydraulic parts with care

Exercise caution when cleaning with a high-pressure cleaner. Bearings, seals and pipe unions are not waterproof. In order to prevent damage to the machine, the bearings, seals and pipe unions must not be exposed to direct contact with the high pressure water jets.

Cleaning and care

General

The following work steps are described in this section:

- »Cleaning«
- »Care«

Cleaning



- ▶ Switch off the tractor PTO shaft drive.
- ▶ Using the hydraulic control device, fold the machine into its work position.
- ▶ Leave the machine coupled to the tractor's lower links.
- ▶ Lock the hydraulic control device.



- ▶ Switch off the tractor engine, put the parking brake in the park position, remove the ignition key and secure the tractor against rolling away.
- ▶ Never clean the bearings and piston rods of hydraulic cylinders using a high-pressure cleaner.
- ▶ After each use, clean the machine of any coarse dirt and crop residue.

After cleaning

- ▶ Lubricate all bearings after cleaning.
→ Observe the chapter »Maintenance« and the following pages.
- ▶ Replace missing warning signs and stickers.

Care

For a long service life, we recommend the following:

- ▶ Apply a protective layer of oil to all uncoated work tools. Only use approved, biodegradable oil, e.g. rapeseed oil.
- ▶ Repair any paint damage.

Setting down the machine in a secure position



When setting down, storing and parking the implement special safety precautions have to be observed:

Observe the safety information

Disregard for safety information can lead to serious or fatal injury. See chapter »Safety«, page 7.

Keep children away from the machine

Forbid children from playing on or around the machine. Select a parking area to which no unauthorised persons have direct access. Metal edges and machine work tools can cause serious injury.

Observe the operator's manual of the tractor manufacturer

Note the instructions and warnings in the operator's manual of the tractor manufacturer. If this requirement is ignored, the consequence may be damage to the machine and even life-threatening injuries.

Never manoeuvre or position in the transport position

Never manoeuvre machines with three-point pickup in the transport position if the machine is not properly connected to the tractor's three-point lifting pick up. When manoeuvring, also make sure that all parking stands are retracted and secured. Otherwise, damage to the machine or life-threatening injuries may be caused as a result.

Risk of tipping when setting down in transport position

The machine must only be uncoupled and set down in transport position on level ground. Also make sure that all parking stands are extended and secured. Select a parking area to which no unauthorised persons have direct access. Otherwise, damage to the machine or life-threatening injuries may be caused as a result.

Make sure the machine is standing level

Before changing from the transport to the work position (and vice versa), make sure the machine is standing level. The machine could tip over, particularly on hillside locations. Otherwise, damage to the machine and serious or fatal injury may be caused as a result.

Parking and storage

General

Uncoupling the machine is carried out in the reverse order to coupling the machine.

»After the end of the season«

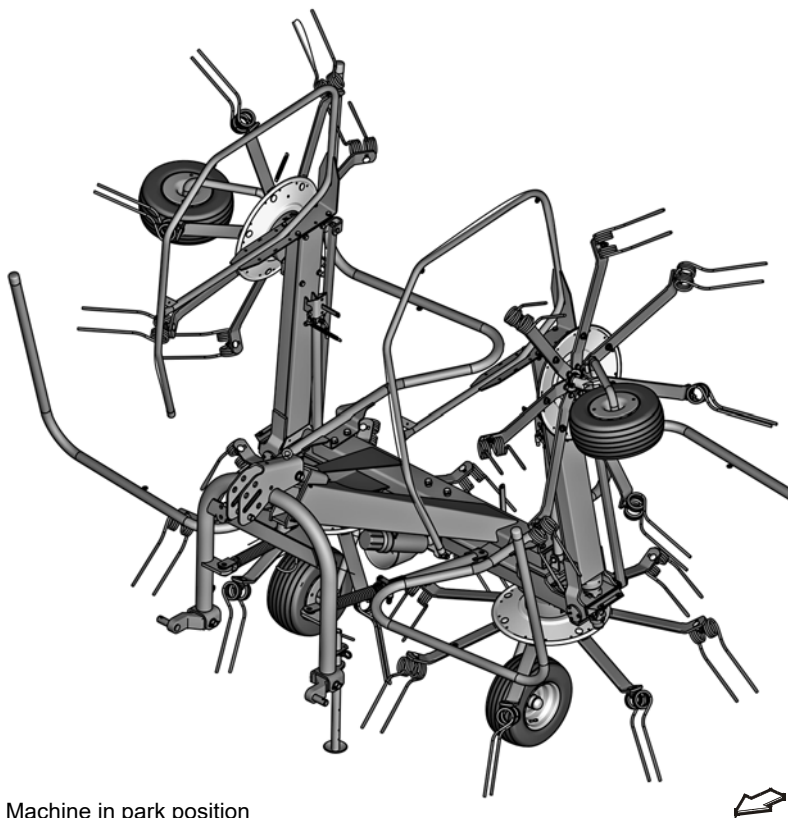

Machine in park position

Uncoupling and securing the machine

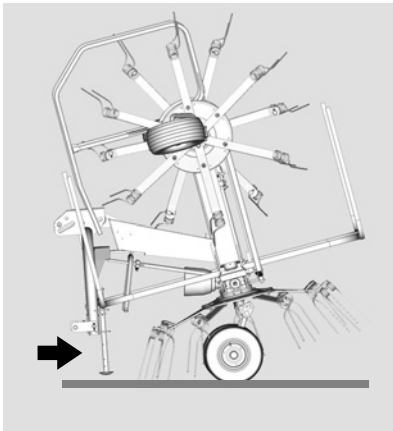

Secure the machine with a parking stand

In the transport position, the parking stand must be used to secure the machine when coupling, uncoupling, parking and storing. The machine could be damaged and serious or fatal injuries could be caused.

To uncouple the machine from the tractor, proceed as follows:



Switch off the tractor PTO shaft drive.



- ▶ Stop the machine in the work position on firm, secure, level ground.
- ▶ Switch off the tractor engine, put the parking brake in the park position, remove the ignition key and secure the tractor against rolling away.

- ▶ Release the hydraulic couplings.
- ▶ Insert hydraulic couplings into the storage pockets on the machine.
- ▶ Disconnect the lighting equipment plug [+] and place it into the storage pockets on the machine.
- ▶ Move the parking stand into the park position and secure it in place.
- ▶ Pull off the PTO shaft on the tractor side and secure with the chain.



- ▶ Switch on the tractor.
- ▶ Disconnect the tractor's top link from the machine.
- ▶ Release the retainer of the lower link guided cone ball to clear the hitch pin on the machine.
- ▶ Lower lower link.
- ▶ Drive the tractor forward with the lower links lowered.

After the end of the season

After the end of the season and if the machine is to be stored for a relatively long period of time, perform the following work:

- ▶ Clean the machine thoroughly.
- ▶ Check all the screw joints and tighten the screws.
 - Observe the correct torque specifications in chapter »Screw and bolt tightening torques« on page 68.
- ▶ Repair or replace any damaged components.
- ▶ Repair any paint damage.
- ▶ Lubricate the machine in accordance with the lubrication schedule.
- ▶ Check the tyre pressures.
- ▶ Replace missing warning signs and stickers.

Safety

The following applies to all servicing work:



Observe the safety information

Disregard for safety information can lead to serious or fatal injury. See chapter »Safety«, page 7.

Requirements for maintenance work

Only perform the maintenance operations if you have the required expert knowledge and suitable tools. The absence of technical knowledge or suitable tools can cause accidents and injuries.

Protect the machine against unintended starting

The following conditions must be observed for carrying out repairs and maintenance work and rectifying malfunctions on the machine when it is coupled:



- Switch off the PTO shaft drive.
- Switch all operating controls to the neutral or park position.
- Put the tractor's parking brake into the park position.
- Switch off the tractor engine, put the parking brake in the park position, remove the ignition key and secure the tractor against rolling away.
- Ensure the machine is standing on firm, secure and level ground, and provide additional support, if necessary.
- Secure the machine against rolling away.

Serious accidents may be caused if the machine starts accidentally.

Use OEM replacement parts

Many components have special properties that are essential for the stability and correct operation of the machine. Only spare parts and accessories supplied by the manufacturer have been tested and approved. Other products may adversely affect the correct operation of the machine and safety. The use of non-OEM replacement parts renders the manufacturer's guarantee null and void and frees the manufacturer from all liability.

Secure moving parts

Moving parts must be secured with lifting gear against sliding, folding or swivelling. Otherwise, serious injury to persons or damage to the machine may be caused as a result.

Disconnect electrical connections before performing welding work

Disconnect all electrical connections from the tractor when carrying out welding on the hitched machine. Otherwise, electrical and hydraulic systems may be damaged as a result.

**Never manoeuvre or position in the transport position**

Never manoeuvre implements with three-point pickup in transport position if the machine is not properly connected to the tractor's three-point lifting pick up. When manoeuvring, also make sure that all parking stands are retracted and secured. Otherwise, damage to the machine or life-threatening injuries may be caused as a result.

Risk of tipping when setting down in transport position

The machine must only be uncoupled and set down in transport position on level ground. Also make sure that all parking stands are extended and secured. Select a parking area to which no unauthorised persons have direct access. Otherwise, damage to the machine or life-threatening injuries may be caused as a result.

Protective measures when handling oils or lubricants

Additives in oils and lubricants may have adverse effects on health. As marking in accordance with the hazardous goods regulation is not necessary, please always ensure the following:

**Avoid skin contact**

Avoid skin contact with these materials. Protect your skin by means of protective skin cream or oil-resistant gloves. Contact can result in skin damage.

Do not use oils for cleaning

Do not use oils or lubricants to clean your hands. Swarf and abraded material in these materials can also result in injuries.

Change any soiled clothing

Change out of clothing that is heavily soiled with oil as soon as possible. Oils can be hazardous to your health.



- Used oil must be collected and disposed of.
- If the skin is damaged by oil or lubricant, seek medical advice immediately.

Maintenance

General

This information relates to general servicing work. For all servicing work, the machine must be locked in the work position. If transport position is required for maintenance work, you will find appropriate information for the maintenance work.

- ▶ Lower the machine to the work position.
- ▶ Secure the machine against rolling away by using chocks.

Direction information

Direction information (right, left, front, rear) is given in relation to the direction of travel. Rotary direction is defined as follows:

- Rotary direction right = clockwise.
- Rotary direction left = counterclockwise.
- Rotation about a vertical axis, viewed from top to bottom.
- Rotation about a horizontal axis, viewed at right angles to the direction of travel, from left to right.
- The rotation of screws and nuts, etc. is always viewed from the operating side.

Maintenance terms

Listed in this table are short explanations of the most important maintenance terms.

Task	Explanation
Greasing	Apply grease to the slide surfaces using a brush.
Lubrication	One or two presses of the grease gun, unless specified otherwise.
Oiling	Unless specified otherwise, use only plant-based oils, such as rapeseed oils. The use of used oil will endanger your health and is also strictly prohibited.
Replacement	Replace the appropriate part in accordance with the instruction in the Maintenance chapter.
Inspection	Check the tyre pressures, adjustment dimensions and seal tightness as required, and replace any worn parts or seals.
Observe the maintenance intervals	The specifications relate to an average usage of the machine. If subjected to heavier duty (e.g. by contracting companies), select the maintenance intervals to be shorter. Also, for extreme working conditions (for example heavy dust creation), shorter maintenance intervals are possible.

Lubricant

Lubricant used on this machine must meet the following requirements:

Lubricant	Specifications
Gear oil	SAE 90 API-GL-4 or 5
e.g.: KUBOTA HEAVY DUTY 80W-90 GEAR OIL	
Grease	NLGI GC/LB
e.g.: KUBOTA Polyurea Grease	

Maintenance intervals

	After the first 5 hours of operation	Daily	After 100 hours of operation	After 250 hours of operation	Once per season	After heavy use	As required	In case of wear	Lubrication	Greasing	Inspection	Replacement	Cleaning	Page
General														
All screws	●				●		●							67
Visual inspection		●				●					●			
Rotor gear						●				●				72
Hose connections					●						●			
Air pressure		●					●				●			74
Lighting equipment							●				●		●	
Hydraulics														
Hydraulic hoses every 6 years					●		●				●	●		74
Hydraulic cylinders					●	●	●				●			
Hydraulic couplings							●						●	
PTO shafts														
Main drive PTO shaft			●		●				●		●			71
PTO shaft guard				●	●				●		●			71

Screwed connections



Use original parts

Many components have special properties that are essential for the stability and correct operation of the machine. Only spare parts and accessories supplied by the manufacturer have been tested and approved. Other products may adversely affect the correct operation of the machine and safety. The use of non-OEM replacement parts renders the manufacturer's guarantee null and void and frees the manufacturer from all liability.

On this machine, bolts with a minimum quality of "8.8" (can be seen on the bolt head) are used.

Tightening screws

All bolts must be retightened:

- After the first 5 hours of operation.
- According to the frequency of use.

At least once a season.

Screw and bolt tightening torques

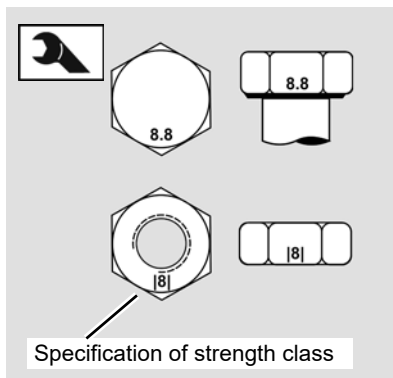

Use the correct screw and bolt tightening torques

Securely tighten screws, nuts and bolts to the specified torques. Otherwise, damage to the machine and serious or fatal injury may be caused as a result.

Note the strength class specification for screws, nuts and bolts. Refer to the table for the corresponding tightening torque. Securely tighten screws, nuts and bolts to the specified values, provided that no other value is specified. The torque specifications refer to a dry coefficient of friction (0.12).

Bolt size	Bolt quality		
	8.8	10.9	12.9
M 6	9.9 Nm (7.3 ft.lbs)	14 Nm (10.3 ft.lbs)	17 Nm (12.5 ft.lbs)
M 8	24 Nm (18 ft.lbs)	34 Nm (25 ft.lbs)	41 Nm (31 ft.lbs)
M 10	48 Nm (36 ft.lbs)	68 Nm (51 ft.lbs)	81 Nm (60 ft.lbs)
M 12	85 Nm (63 ft.lbs)	120 Nm (89 ft.lbs)	145 Nm (107 ft.lbs)
M 14	135 Nm (100 ft.lbs)	190 Nm (140 ft.lbs)	230 Nm (166 ft.lbs)
M 16	210 Nm (155 ft.lbs)	290 Nm (214 ft.lbs)	350 Nm (258 ft.lbs)
M 20	410 Nm (302 ft.lbs)	580 Nm (428 ft.lbs)	690 Nm (509 ft.lbs)



Tighten safety bolts and nuts with a 10% higher value.



On a level surface, tighten the bolts evenly, alternating between the bolts. This ensures that the connection is distortion-free. Otherwise, damage to the machine may be caused as a result.

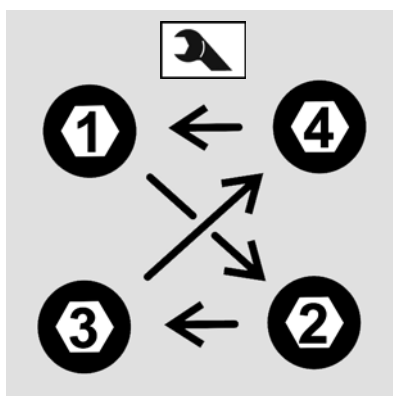

Special tightening torques



Use correct tightening torque

Securely tighten screws, nuts and bolts to the specified torques. Otherwise, damage to the machine and serious or fatal injury may be caused as a result.

Observe the special screw and bolt tightening torques for the following screwed connections:

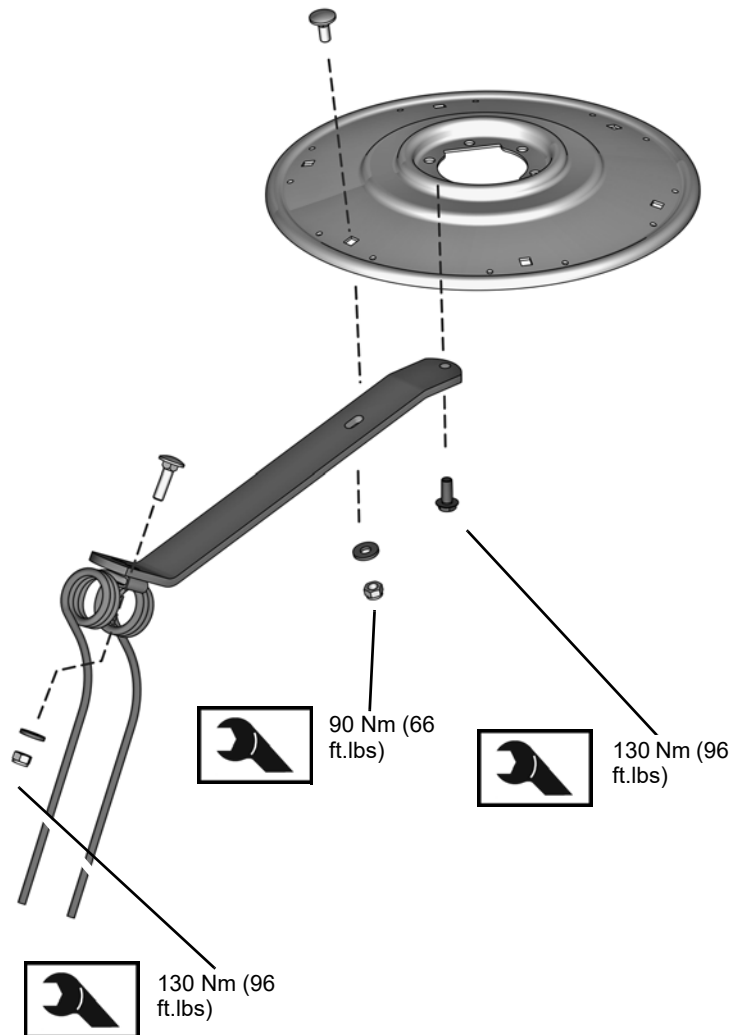

- ▶ Running wheel nuts: 20 Nm (15 ft.lbs).

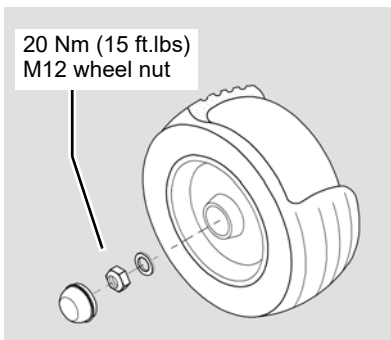

Lubrication points for grease lubrication

Working with a grease gun

Lubricate all of the areas marked in the illustration as follows:

- After 30 hours of operation.
- Before and after the season.
- Each time after cleaning with a high-pressure cleaner.

Before applying the grease gun

- ▶ clean grease fittings and
- ▶ grease gun attachment fitting.

Lubricate the bearings with one or two presses of the grease gun. If you feel resistance at the second press, do not proceed any further. Too much grease will force the bearings apart. Dust and dirt can penetrate into the bearings. This leads to premature wear.

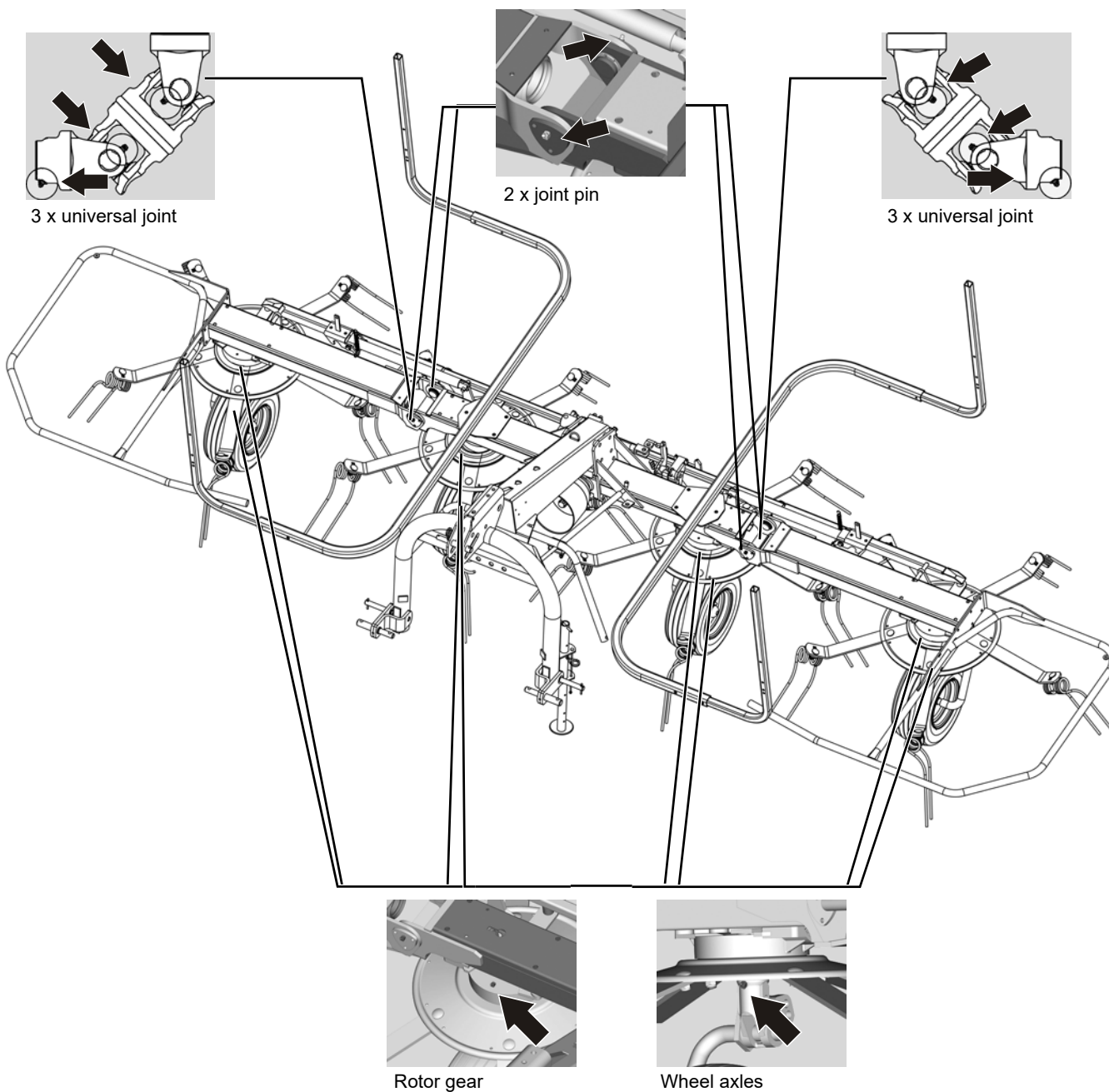

Lubricating the PTO shafts

The manufacturer's own operator's manual is attached to each PTO shaft. This includes detailed information on the relevant version of the PTO shaft.



Check the guard components

Check all guard components of the PTO shafts for wear or damage (visual inspection). Replace any defective guard components. An unguarded PTO shaft or damaged guard components can cause very serious injuries during operation.

Lubricate the single joints and their couplings as follows:

- After 100 hours of operation.
- Before and after the season.
- Each time after cleaning with a high-pressure cleaner.

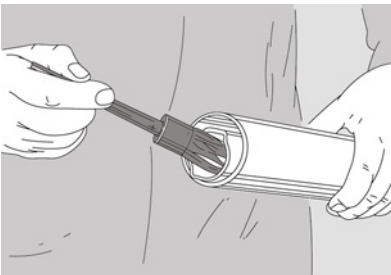

Grease the profile section tubes (P):

- daily.
- After 100 hours of operation.
- Before and after the season.
- Each time after cleaning with a high-pressure cleaner.

Lubricate the guard (S) as follows:

- after 250 hours of operation.
- Before and after the season.
- Each time after cleaning with a high-pressure cleaner

PTO shaft for main drive

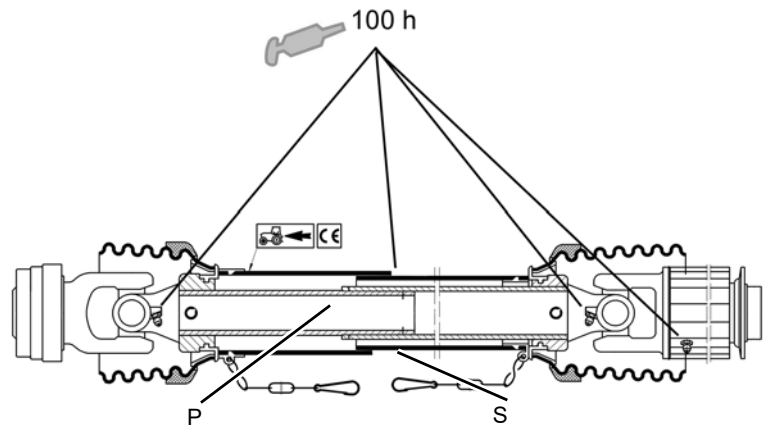

Slip clutch

The slip clutch is maintenance free.

Filling quantities



Observe the correct fill quantities

Observe the correct lubricant fill quantities. Check them regularly. A lubricant level which is too low or too high may result in damage to the machine.

The main gear box and rotor gear require no maintenance.

Gearbox	Quantity	Lubricant
Main gear box	1.2 l (1.3 US qt)	Gear oil: SAE 90 API-GL-4 or 5
Rotor gear	200 g (0.440 lbs)	Grease: NLGI GC/LB

Main gear box

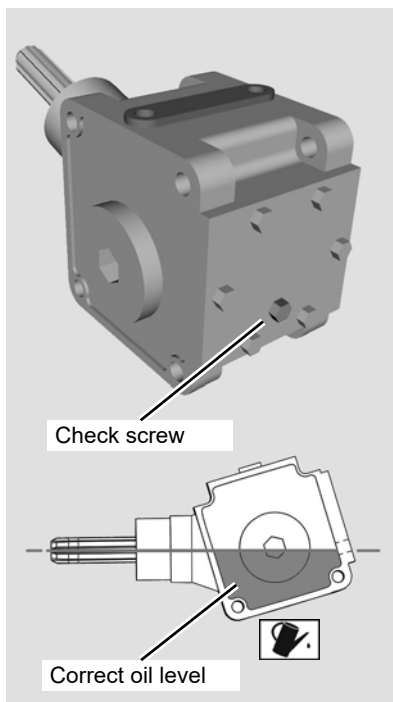

- No oil change is required.
- The maintenance-free main gear box is filled ex works with sufficient oil.
- Only check the oil level in the work position (machine positioned horizontally), if there is visible oil loss.

Checking the oil level:

- ▶ Fold the machine into its work position.
- ▶ Undo the check screw completely.
- ▶ Check the oil level.
 - Correct oil level: bottom edge of check screw hole.



Check the main gear box at least once per season. If there is a visible loss of lubricant, consult your dealer. Otherwise, damage to the machine may be caused as a result.

Rotor gear

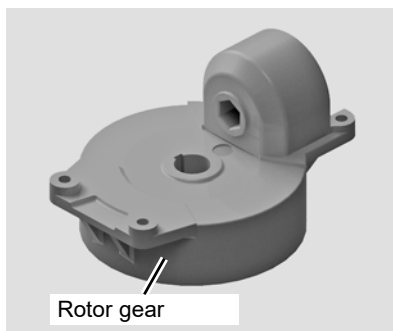

The maintenance-free rotor gears are filled ex works with sufficient grease.



- The grease must not be changed.
- The locking pieces should be greased:
 - See »Lubrication points for grease lubrication«, page 70.
 - See »Maintenance intervals«, page 67.

Tyres

**Do not drive with worn or damaged tyres**

Replace worn or damaged tyres. Damaged tyres and incorrect tyre pressure may cause damage to the machine.

Tyre pressure

Check the tyre pressures on a regular basis:

- Daily
- Before any road transport
- As required (for example before setting the tine height)
- Before and after the season

Tyre size	Tyre pressure
16 x 6.00-6	1.5 bar

Hydraulics



Hydraulic system at zero pressure

Work must only be performed on the hydraulic system if the tractor and machine hydraulic system is at zero pressure. A pressurised hydraulic system can trigger unpredictable movements of the machine and can cause serious machine damage and personal injury. Serious or fatal injury may be caused as a result.

Exercise caution when welding

Do not perform any welding work in the vicinity of the hydraulic hoses. Hydraulic oil can catch fire very easily.

Clean hydraulic system

Close or disconnect the quick couplings with great care. Remove any dirt or air which has entered the hydraulic system. The hydraulic system may otherwise be seriously damaged. Material damage or personal injury may be caused as a result.

Collect escaping oil

Escaping oil must be collected and disposed of in accordance with national regulations. Otherwise, damage may be caused to the environment.

Hydraulic hoses



Replace hydraulic hoses every six years or sooner

Hydraulic hoses age without showing externally visible signs. Replace hydraulic hoses every six years or sooner. Use hydraulic hoses only with the same technical specifications. The required information is printed on the hydraulic hose. Defective or incorrect hydraulic lines can cause serious or fatal injuries.

To replace the hydraulic hoses:



- ▶ Lower the machine to the work position.
- ▶ Depressurise the system.
- ▶ Switch off the tractor engine, put the parking brake in the park position, remove the ignition key and secure the tractor against rolling away.
- ▶ Disconnect the hydraulic hoses.
- ▶ Replace hydraulic hoses.

Accessories

Optional additional equipment does not form part of the standard scope of delivery, and, in this manual, is indicated by a plus symbol [+]. Additional equipment is available to order from your dealer.

Tine saver

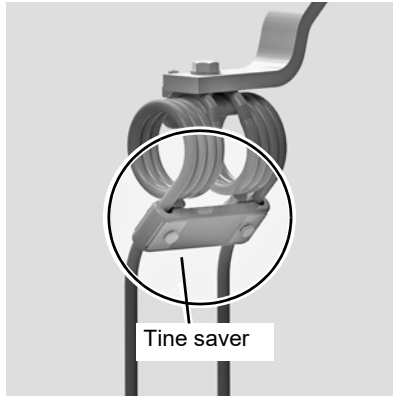

If tines are broken, the tine savers can prevent the broken-off part from being lost. Broken-off tine parts in the crop may damage machines that are following behind.

- The flexible plastic holders can be easily attached and released again.
- One tine saver is required for each tine.



For a good crop pick-up, both tine legs must be parallel after fitting the tine saver.



If the tine saver is overtightened, the tine legs become splayed.

Night swath gear box



A night swath gear box is available in order to use the rotary tedder to lay down night swaths for the hay harvest. The night swath gear box reduces the speed of the PTO shaft. The crop is not spread but deposited between two rotors as a swath.

- ▶ Remove the existing protective pot on the central transmission.
- ▶ Slide the night swath gear box with the protective pot onto the central transmission shaft and secure it with a circlip.
- ▶ Secure the night swath gear box with the grub screw.
- ▶ Fit the PTO shaft on the side shaft end.

Contact roller

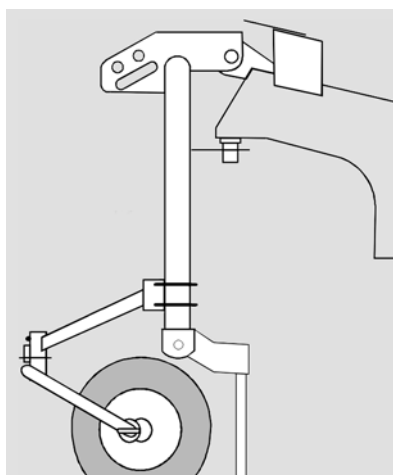

To prevent damage to the stubble on particularly uneven terrain, as well as to avoid leaving any crop behind, a contact roller can be fitted to the three-point linkage as additional equipment.

The assembly instructions for your machine describe how to fit the additional equipment.

→ Please consult your dealer.

Accessories

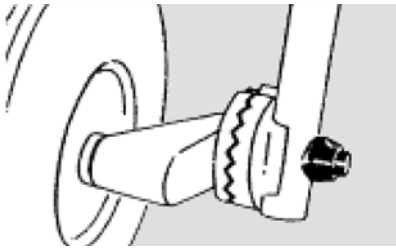

Adjusting the height of the contact roller:

- ▶ Release the lock nut.
- ▶ Adjust the contact roller by turning the split serrated disc to the desired height.
- ▶ Retighten the lock nut.

Spare wheel

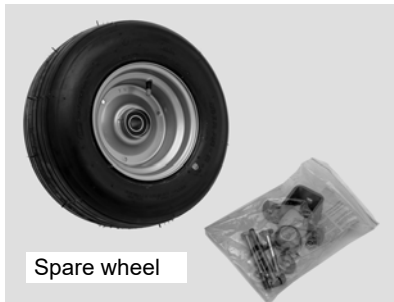

The optional spare wheel can replace any wheel on the machine.

- ▶ Fit the holder for the spare wheel onto the left-hand outer device.
- ▶ Fit the spare wheel on the holder.

Anti-wrapping plate

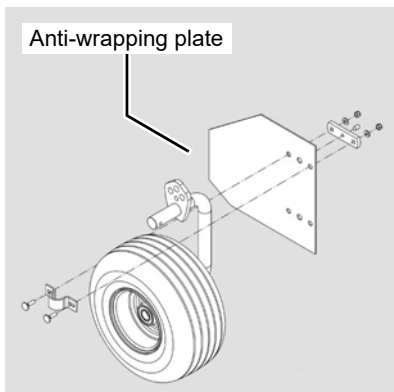

The anti-wrapping plate ensures a perfect, uniform feed flow. It stops the feed getting wrapped around the running wheel axles.

- ▶ The anti-wrapping plates are fitted to the running wheel axles in the work position, as shown.

Slope locking mechanism

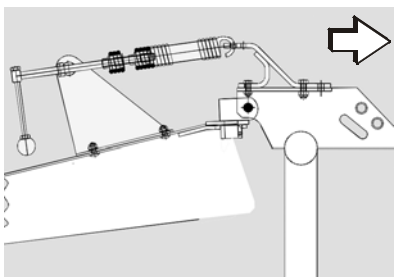

The slope locking mechanism improves ground contact when travelling on hills and ensures that the rotors gather the crop reliably, even on hillside locations.

The slope locking mechanism is fitted between the three-point linkage and the machine frame.

→ Please consult your dealer.

Warning sign kit

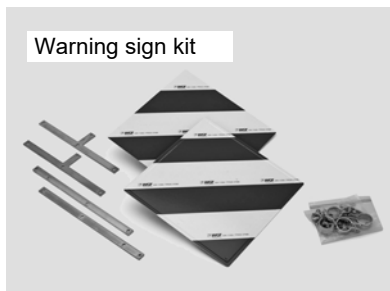

The optional warning sign kit increases safety when travelling on the road.

Lighting equipment set



The optional lighting equipment set increases safety when travelling on the road.

Hydraulic border tending system



The optional hydraulic border tending system facilitates work at the edge of fields.



The hydraulic border tending system is delivered with a separate manual.

Fault elimination

Fault

Faults can often be eliminated quickly and easily. Before contacting Customer Service, refer to the table to check whether you can remedy the fault yourself.



In case of a fault, proceed as follows:

- ▶ Immediately stop operation.
- Switch off the PTO shaft drive.
- Switch all operating controls to the neutral or park position.
- Put the tractor's parking brake into the park position.
- Switch off the tractor engine, put the parking brake in the park position, remove the ignition key and secure the tractor against rolling away.
- Ensure the machine is standing on firm, secure and level ground, and provide additional support, if necessary.
- Secure the machine against rolling away.

The fault must be repaired before work can be resumed. Damage to the machine and serious or fatal injury may be caused as a result.

Fault	Causes	Remedy
Rotor is leaving crop behind across the entire width.	Working depth set too high.	→ »Adjusting the working depth«, page 43
Fodder is heavily contaminated.	Working depth set too low.	→ »Adjusting the rotor pitch«, page 44
Machine not operating cleanly at high speed	Rotor tines set too high.	Reduce speed.
	Speed too fast to process the amount of fodder.	
Slip clutch responding frequently.	Fodder mass too great or irregular.	Reduce speed. Reduce PTO stub shaft speed.
	Working depth set too low.	→ »Adjusting the working depth«, page 43 → »Adjusting the rotor pitch«, page 44
Noise production during work.	Loose screwed connections or worn-out tine supports.	Check tine supports and screwed connections on tines.
	Broken tines on the tine saver.	Replace the tines.

Hydraulic diagram

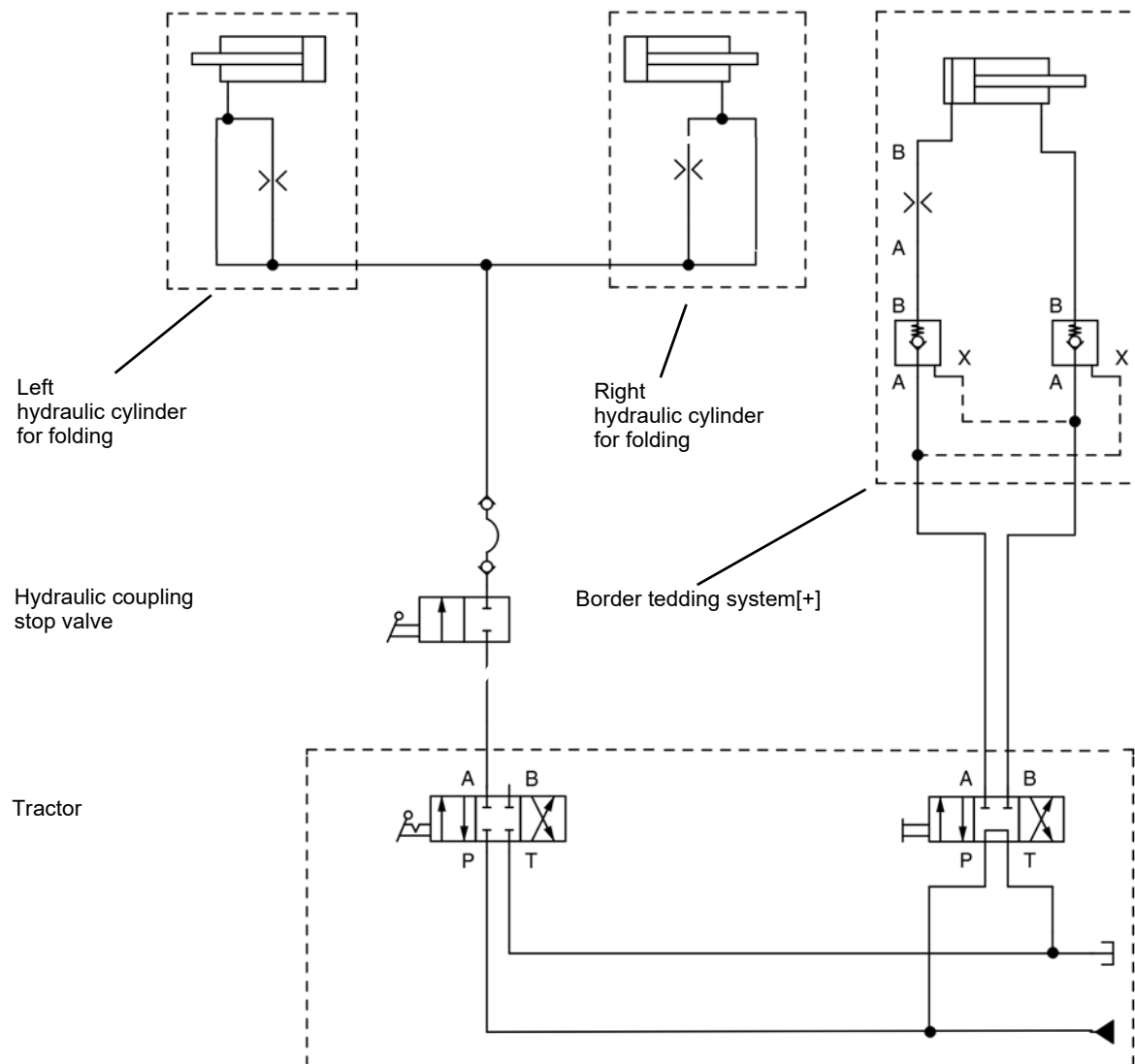

Lighting circuit diagram [+]

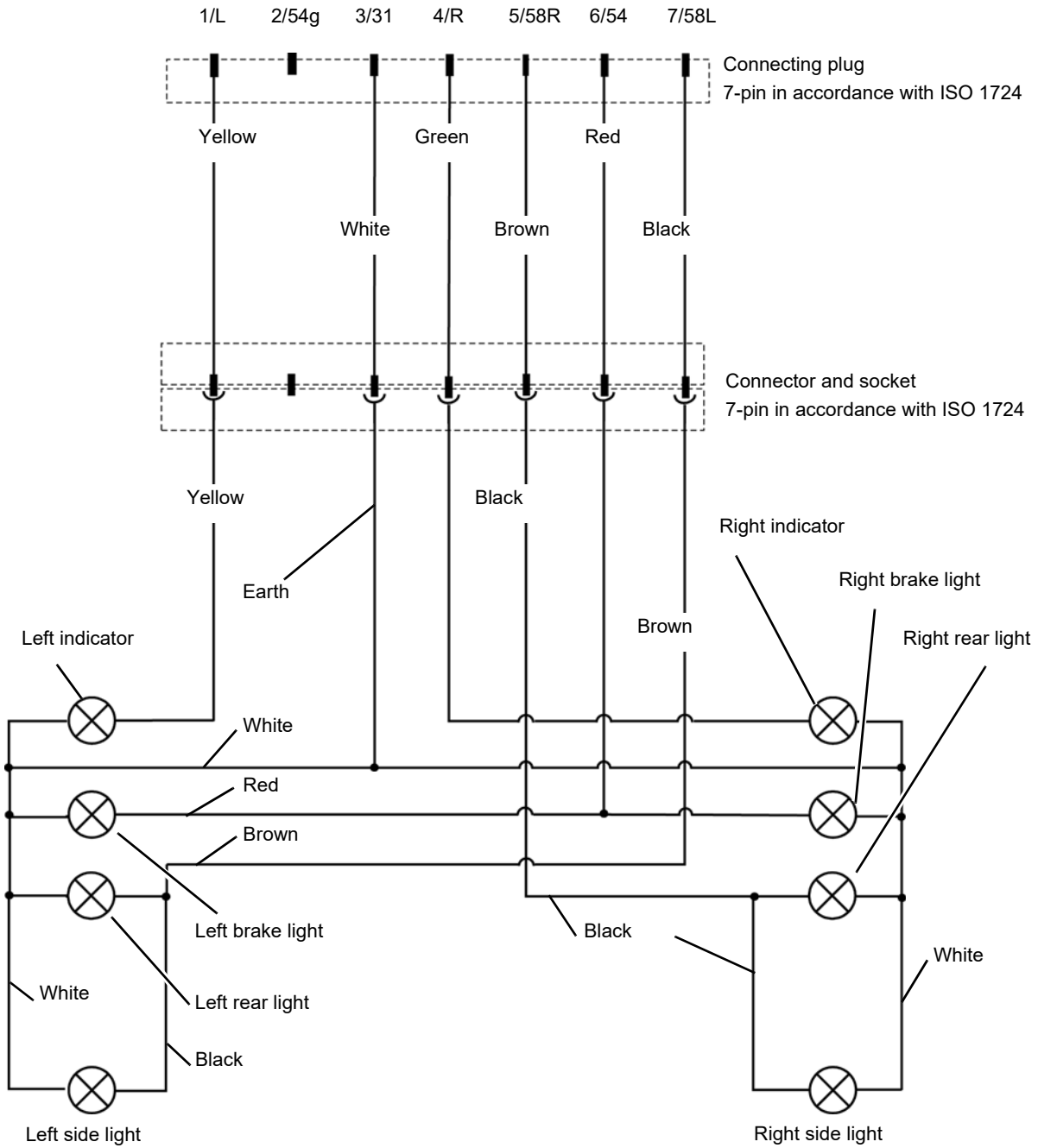

Disposal

During decommissioning, the individual parts must be disposed of properly and in an environmentally friendly manner. Please observe the waste disposal guidelines that are currently in force.

Plastic parts

Plastic parts can be disposed of in normal household waste (residual waste), depending on the laws specific to your country.

Metal parts

All metal parts can be sent for recycling.

Oil

In terms of waste legislation, environmentally-compatible hydraulic oils must be stored, collected and disposed of separately in accordance with regulations.

Rubber

Rubber parts, such as hoses or tyres, must be disposed of at a rubber recycling facility.

Original EC Declaration of Conformity

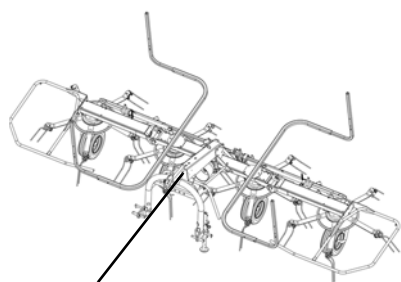

Type plate and CE marking

We

**Kverneland Group Kerteminde AS
Taarupstrandvej 25
DK-5300 Kerteminde
Denmark**

declare with sole responsibility that the product

**Vicon Fanex 464 / Fanex 524
Kubota TE4046/TE4052
Kverneland 8446 / 8452
in all equipment variants and its
accessories**

Model: 6590 / 6597

**Valid from machine number:
VF65902110 / VF65974001**

complies with the following relevant EU provisions:

- Directive 2006/42/EC
- Directive 2014/30/EU

The following harmonised standards have been applied:

- EN ISO 4254-1:2015
- EN ISO 4254-10:2009 + AC:2010

Kverneland Group Kerteminde AS
Kerteminde, 02.01.2021

A handwritten signature in black ink, appearing to read 'Claus Udengaard Thomsen'. The signature is fluid and cursive, written over a horizontal line.

Claus Udengaard Thomsen

CEO
and authorised representative*

* person who is responsible for compiling the technical documentation and resides in the European Community. See address above.

B			
Border tending	57		
Border tending system			
Adjusting	57		
Manual	57		
C			
Care	60		
Check list			
Work position	52		
Circuit diagrams			
Hydraulic diagram	79		
Lighting equipment	80		
Cleaning	60		
Coupling			
PTO shaft	38		
Coupling the three-point linkage	34		
D			
Designation of components	25		
Direction information	66		
Disposal			
Metal parts	81		
Plastic parts	81		
F			
Field edge clearing	57		
Fitting the tine supports	53		
I			
Information on the implement	24		
Inserting the parking stand	37		
L			
Lubrication points	70, 74		
General	70		
M			
Machine			
Putting away after the season	63		
Setting down	61		
Uncoupling	62, 63		
Maintenance	64		
Lubrication points	70		
Maintenance intervals	67		
O			
Oil			
disposal of		65	
Protective measures		65	
P			
Preparation			
Work position		52	
Preparations on the field		51	
Preparing for operation		42	
Proper use		24	
PTO shaft			
Attaching		38	
S			
Safety			
Care and maintenance		19	
Pictorial symbols		8	
Unhitching		18	
Speed		49	
T			
Technical specifications		26	
Tractor equipment		27	
Tractors with quick-release couplings		35	
Tractors without quick-release coupling		35	
Tyre pressure		73	
Tyres		73	
U			
Uncoupling			
Machine		63	
W			
Weights		27, 30	