

Operator's manual

Original operator's manual

Edition	06.2014
Date of print	10.2021
Language	EN
Machine number	VF65892140 –
Model	VF6589
Document number	VF16645560.EN



REGISTER YOUR PRODUCT NOW:
MY.KVERNELAND.COM

Machine identification

In order for your dealer to assist you as efficiently as possible, you will need to provide some information about your machine. Please enter the details here:

Designation 9032

Operating width 3.20 m (10.5 ft)

Weight 320 kg (706 lbs)

Machine number VF6589 _ _ _ _

Accessories

Address of supplier

Address of the manufacturer
Kverneland Group Kerteminde AS
Taarupstrandvej 25
DK-5300 Kerteminde
Denmark
Tel: +45 65 19 19 00

By registering your Kverneland product at my.kverneland.com you will benefit from easy access to Kverneland's online service tools and updated information.



Preface	4	Operation	56
Target group for this operator's manual	4	Safety	56
Symbols used	5	General	57
Safety	7	Crop processing	57
For your safety	7	Swathing	58
Who is allowed to operate the machine?	11	Driving on headlands	60
General safety information	11	Cleaning and care	61
Coupling	14	Safety	61
Road transport	15	General	62
Operation	16	Cleaning	62
Uncoupling	17	Care	62
Care and maintenance	18	Parking and storage	63
Distance from the centre of gravity	19	Setting down the machine in a secure position	63
Further regulations	21	General	63
Getting to know the machine	22	After the end of the season	64
Range of application	22	Maintenance	65
Features	22	Safety	65
Designation of components	23	General	66
Technical specifications	24	Screwed connections	69
Delivery and assembly	28	Lubrication points for grease lubrication	71
Checking the scope of delivery	28	Lubricating the PTO shafts	73
Length of PTO shaft	29	Filling quantities	74
Coupling the machine	31	Tyres	74
Safety	31	Accessories	75
General	31	Fault elimination	77
Coupling the three-point linkage	32	Troubleshooting	77
Inserting the parking stand	34	Circuit diagrams	78
Coupling the PTO shaft	35	Lighting circuit diagram	78
Connecting the electrics	36	Decommissioning	79
Preparing for use	37	Disposal	79
Safety	37	Original EC Conformity Declaration	80
General	38	Index	81
Adjusting the machine	38		
Machine pitch	39		
Rotor pitch	39		
Working depth	41		
Slope locking mechanism [+]	42		
Road transport	43		
Safety	43		
Prior to road transport	44		
Road transport	48		
Preparations on the field	50		
Safety	50		
General	50		
Folding the machine into the work position	50		
Basic settings	53		

Target group for this operator's manual



Simplified illustrations for better understanding

Illustrations of the machine in the operator's manual are shown without protective equipment – or with the protective equipment open – for better understanding. Be sure to observe the safety information and follow the handling instructions in the operator's manual. Serious or fatal injury may be caused as a result.

This operator's manual is intended for trained farmers and individuals who are otherwise qualified to perform agricultural activities and who have received instruction in the operation of this machinery.

For your safety

You must familiarise yourself with the contents of this operator's manual before assembly or initial operation of the machine. In this way, you will achieve optimum work results and operational safety. The operator's manual forms an integral part of the machine and must always be kept to hand. This will ensure that you:

- avoid accidents.
- comply with warranty conditions.
- have a fully functional machine in good working order at all times.

Training and instruction

Your dealer will provide instruction on operation and care of the machine.

Information for the employer

All personnel are to be regularly, but at least once a year, instructed on the use of the machine, in accordance with the regulations of the national organisation for Health and Safety at Work. Untrained or unauthorised persons are not permitted to use the machine.

You are responsible for ensuring that the machine is operated and maintained safely. Make sure that you and all other persons that operate, maintain or work in close proximity with the machine are familiar with the operating and maintenance regulations, as well as the corresponding safety instructions in this operator's manual.

Symbols used

In this operator's manual, the following symbols and terms have been used:

- A bullet point accompanies each item in a list.
- ▶ A triangle indicates operating functions which must be performed.

→ An arrow indicates a cross-reference to other sections of this manual.

[+] A plus sign indicates additional equipment which is not included in the standard version.



The warning triangle indicates warning information. Failure to observe these safety instructions can result in:

- Moderate to serious injury
- Fatal injury

The warning information in the operator's manual is specifically associated with individual operations and instructions. It is important to observe the warning information before these operations are carried out.

In the »Safety« chapter, you will also find safety information which is not related to individual operations, but rather is designed to encourage safety-conscious behaviour in various situations.



The information triangle indicates important information. Failure to observe these safety instructions can result in:

- Serious faults in the correct operation of the machine
- Damage to the machine

We have also used pictograms to help you find instructions more quickly:



The "Information" pictogram indicates tips and additional information.



The "Examples" pictogram indicates examples that assist understanding of the instructions.



The spanner indicates tips for assembly or adjustment work.



This arrow in the diagram shows the direction of travel.



▶ Switch on the tractor.



▶ Switch off the tractor engine, put the parking brake in the park position, remove the ignition key and secure the tractor against rolling away.

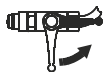

▶ Open the ball valve.

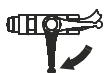

▶ Close the ball valve.



The grease gun indicates the points that must be lubricated using the grease gun.



The brush indicates the points that must be lubricated using the brush.



For your safety

Familiarise yourself with your equipment and its limitations. Read the entire manual before attempting to put the machine into operation and to use it.

This chapter contains general safety instructions. Each chapter of the operator's manual contains additional specific safety information which is not described here. Observe the safety information:

- in the interest of your own safety.
- in the interest of the safety of others.
- to ensure the safety of the machine.

Numerous risks can result from handling agricultural machinery in the wrong way. Therefore, always work with particular care and never under time pressure.

Information for the employer

Inform all persons who work with the machine about this safety information at regular intervals and in accordance with statutory regulations.



Warning signs

Safety-related labels attached to the machine indicate potential hazards. The labels must not be removed. Illegible or missing labels should be replaced. You can obtain new labels as replacement parts from your dealer.

Warning signs on the machine

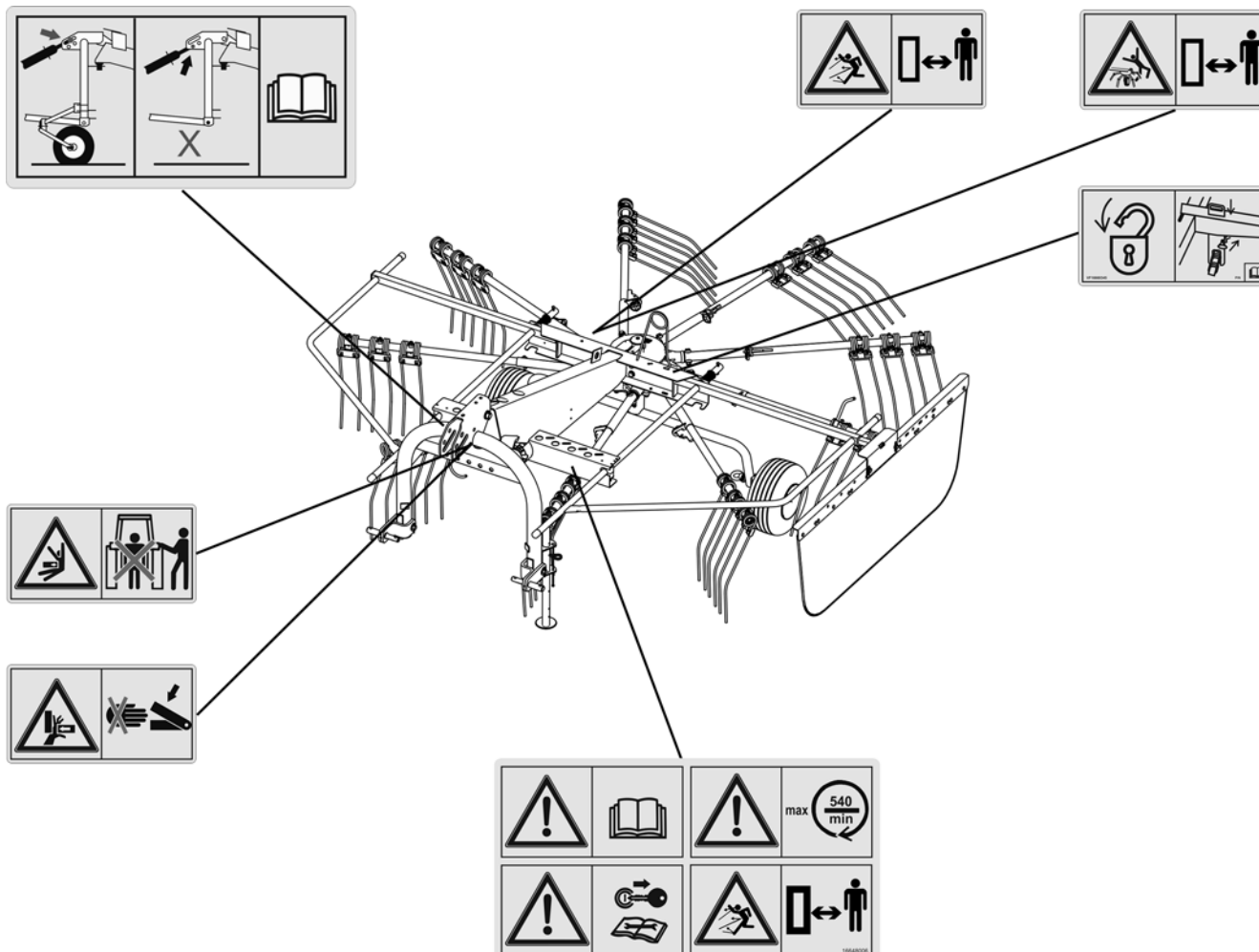



Meaning of warning signs



Read the operator's manual

Read and observe the operator's manual and the safety instructions before using the machine for the first time. The machine must not be used for the first time until the operator's manual has been read and understood. This applies in particular to the safety information. Serious or fatal injury may be caused as a result.



Switch off the engine

Only perform maintenance, repair and adjustment work when the machine is shut down. Serious or fatal injury may be caused as a result.



Distance from the rotor

Maintain a safe distance from the rotor when it is rotating. Nobody may remain in close proximity to the machine when tedders and rakes are running. Serious or fatal injury may be caused as a result.



Distance from tractor

When the machine is being coupled, uncoupled or operated, there should be no-one between the tractor and the machine. Serious or fatal injury may be caused as a result.



Risk of crushing

Never reach into an area where there is a risk of crushing if parts in that area are still likely to move. Serious or fatal injury may be caused as a result.



Caution, parts ejected at speed

Hazard caused by parts which may become detached when the drive is in operation, and ejected at speed. Maintain a safe distance. Serious or fatal injury may be caused as a result.



Securing the swath former in the transport position

Secure the swath former after it is folded up into the transport position. The swath former may fold down unexpectedly. Otherwise, serious or fatal injury may be caused as a result.



Securing the rotor

Secure the rotor in the transport position. The rotor may turn unexpectedly due to centrifugal forces. Otherwise, serious or fatal injury may be caused as a result.



PTO shaft speed 540 rpm

The specified maximum PTO shaft speed of 540 rpm must not be exceeded. Otherwise, damage to the machine may be caused as a result.

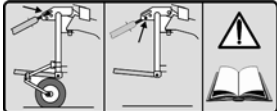

Information about coupling the top link

When coupling the top link, ensure that the hitch pin is correctly fitted. Otherwise, damage to the machine may be caused as a result:

- When using the optional support wheel:
 - ▶ Peg the hitch pin in the elongated hole and secure it with a safety splint.
- Without a support wheel:
 - ▶ Peg the hitch pin in the hole and secure it with a safety splint.



Who is allowed to operate the machine?

Only qualified personnel

Only qualified persons who have been informed of the dangers associated with handling the machine are permitted to operate, service or repair the machine. The necessary knowledge can be gained in the course of agricultural vocational training, professional training or intensive instruction.

General safety information

The general safety information and warning signs apply to every phase of the life cycle of the machine and to every application.



Switch off the tractor and secure it

Before you dismount:

- ▶ Switch off the PTO shaft drive.
- ▶ Lower all implements.
- ▶ Switch all operating controls to the neutral or park position.
- ▶ Put the tractor's parking brake into the park position.
- ▶ Switch off the tractor.
- ▶ Remove the ignition key.
- ▶ Secure the tractor against rolling away.

An unsecured tractor can run you over or trap you. Serious or fatal injury may be caused as a result.

Operate for the first time only after proper training

The machine may only be put into operation if thorough training has been carried out by an authorised dealer or by an employee of the manufacturer. Operation without proper training can lead to damage to the machine due to incorrect operation, or may cause accidents.

Safety is your responsibility

Follow the safety instructions. Ensure that all operators comply with the safety instructions. Prevent serious or fatal accidents by following the safety instructions.

Instructions in the event of malfunctions

In the event of a malfunction

- ▶ shut down,
- ▶ stop and secure the machine immediately.
- ▶ Immediately rectify the faults, if you are qualified to do so,
- ▶ or commission an authorised dealer.

Operating a faulty machine can cause accidents or damage.



No persons in the working area

Ensure that no persons – children in particular – are present in the slewing and working area of the machine. Persons could be caught by the machine within this area. Fatal injury may be caused as a result.

Correct working conditions

Ensure that the tractor and the machine are always in perfect working condition. Make sure that the tractor brakes work in conjunction with the machine. Also follow the instructions in your tractor's operator's manual.



Switch off the PTO shaft drive when raising the machine

Switch off the PTO shaft drive on the tractor if people could enter the working area of the machine when you

- raise the machine,
- raise the rotor to the headland position.

Rotating, unprotected parts can damage the machine and cause life-threatening injuries.



Switch off the tractor PTO shaft drive

Switch off the PTO shaft drive on the tractor when changing from work to transport position (and vice versa). Wait for moving parts to come to a stop. If this requirement is ignored, the consequence may be damage to the machine and even life-threatening injuries.



No reversing while the drive is running

Never drive in reverse with the PTO shaft drive switched on and in the work position if people could enter the working area of the machine. Switch the PTO shaft drive off. Rotating, unprotected parts can damage the machine and cause life-threatening injuries.

Specified workwear

Do not wear baggy, loose-fitting or other unsuitable clothing. Loose fitting items of clothing may become caught in rotating parts. Wear workwear and protective clothing which is suitable for the working environment and the operating conditions. Wear workwear and protective clothing, as specified by the Accident Prevention and Insurance Association. Serious or fatal injury may be caused as a result.

**No riding on the machine**

Persons or objects must never be transported on the machine. Carrying passengers – particularly children – on the machine is life-threatening and prohibited. Serious or fatal injury may be caused as a result.

Safety for children

Never assume that children will remain where you last saw them. Be alert and shut down the machine if children are in the working area of the machine. Prohibit children from playing on or around the machine and from operating the machine.

Never work on the machine while it is running

No operations may be performed on the machine while it is running. Objects or persons can be caught, drawn in or crushed. Serious or fatal injury may be caused as a result.

Safe distance from raised and unsecured loads

Never work under suspended loads. Maintain a sufficient distance from raised and unsecured loads. Serious or fatal injury may be caused as a result.

Only use the PTO shaft specified

Use only the PTO shafts specified by the manufacturer and read the attached operator's manual carefully. Adjust the length of the PTO shaft as required. Incorrect PTO shaft lengths can cause damage to the machine and personal injury.

Check and fasten the PTO shaft guard in position

The rotating PTO shaft is protected by the PTO shaft guard. Ensure that the guard is not damaged. Fasten the PTO shaft guard in position by connecting the chains on the implement and the tractor. Unguarded PTO shafts can cause life-threatening injuries.

Make sure the machine is standing level

Before changing from the transport to the work position (and vice versa), make sure the machine is standing level. The machine could tip over, particularly on hillside locations. Otherwise, damage to the machine and serious or fatal injury may be caused as a result.

Do not make any modifications to the machine

No modifications of any kind may be made to the machine. Unauthorised modifications can adversely affect the correct operation and safety of the machine and shorten its service life. Unauthorised modifications to the machine render the manufacturer's guarantee null and void and free the manufacturer from all liability.



Maximal PTO shaft speed: 540 rpm

The specified maximum PTO shaft speed of 540 rpm must not be exceeded. A higher PTO shaft speed will damage the machine.

Unrestricted field of vision to the rear

After it has been coupled, ensure that you have an unrestricted view of the machine, in both its work and transport positions. Otherwise, dangerous situations may not be detected in good time. Accidents or damage may be caused as a result.

Coupling



Increased risk of injury

When the machine is being coupled to the tractor, there is an increased risk of injury. Therefore:

- Switch off the tractor engine, put the parking brake in the park position, remove the ignition key and secure the tractor against rolling away.
- Never stand between the tractor and machine.
- Lock the PTO shaft securely on the PTO stub shafts of the tractor and the machine.

If this requirement is ignored, the consequence may be damage to the machine and even life-threatening injuries.

Attaching electrical connections after assembly

The electrical supply to the tractor must not be connected when the lighting equipment is being fitted. Otherwise, short circuits may occur and the electronic system may be damaged.

Observe the operator's manual of the PTO shaft manufacturer

Observe the operator's manual of the PTO shaft manufacturer. It will provide you with instructions on how to handle the PTO shaft correctly. If these instructions are ignored, damage may be caused to the PTO shaft and machine.

Risk of tipping due to unsecured quick-release couplings

When the machine is coupled to tractors with lower link quick-release couplings, the quick-release couplings must be secured against unintentional opening. If the quick-release couplings open unintentionally, the tractor and machine may tip over. If this requirement is ignored, the consequence may be damage to the machine and even life-threatening injuries. Also follow the instructions in your tractor's operator's manual.



Road transport

Ensuring road safety

The machine must conform to current national traffic regulations if you intend to drive with it on public roads. Ensure the following:

- Lighting, warning and protective equipment must be fitted.
- The permissible transport widths and weights, axle loads, tyre load-bearing capacities, laden weights and national speed restrictions must be complied with.
- The maximum permissible road transport speed must be complied with, but not exceed 50 km/h (30 mph).
- Before driving on public roads, fold in all guard bars and secure the machine. All tine supports which have tips that point at right angles to the direction of travel must be removed.
- The machine should only be hitched to agricultural or forestry tractors.

The empty weight of the tractor must be greater than the weight of the machine. The driver and keeper of the vehicle are liable should these conditions not be observed.

Check tyre pressures

Check tyre pressures on a regular basis. Incorrect tyre pressure reduces the service life of the tyre.

Altered driving and braking performance

Driving and braking characteristics are altered when the machine is coupled or hitched to the tractor. When cornering, take the overall width and balancing weight of the machine into consideration. Adapt your driving speed accordingly. A driving style which is not adapted to conditions can cause accidents. Accidents with serious or fatal injuries may be caused as a result.



Speed adjustment

In poor road conditions and at high speeds, significant forces can be generated which subject the tractor and machine material to high or excessive stresses. Adjust your driving speed to the road conditions. A driving style which is not adapted to conditions can cause accidents. Accidents with serious or fatal injuries may be caused as a result.

Check hitch pins

Hitch pins must be in perfect condition. Hitch pins must show no signs of wear and be properly secured. Otherwise, hitched machines may detach themselves of their own accord. Accidents with serious or fatal injuries may be caused as a result.

Check release cords on quick-release couplings

Release cords must hang loose and must not allow a release in their lowered position. Hitched machines may otherwise detach themselves from the lower link hitching system of their own accord. Accidents with serious or fatal injuries may be caused as a result.

Operation

Operate for the first time only after proper training

The machine may only be put into operation after proper training has been provided by an employee from a dealership or the manufacturer, or by a factory representative. Operation without training can lead to damage to the machine due to incorrect operation, or cause accidents.

Ensure that the machine is in technically perfect working condition

Do not operate the machine unless it is in perfect working condition. Check all key components and their correct operation before use. Replace defective components. Defective components can cause material damage and personal injury.

Check the protective equipment

The protective equipment must not be removed or by-passed. Check all protective equipment before using the machine. Unprotected machine parts can cause serious or fatal injury.



Check the immediate vicinity

Check the area immediately surrounding the machine before driving off, and continually during operation. Make sure that you have an adequate view. Only begin work when the immediate vicinity is cleared of any persons or objects. Serious or fatal injury may be caused as a result.

Retighten all nuts, bolts and screws

Regularly check that nuts and bolts are correctly tightened. Retighten bolts if necessary. Nuts and bolts can work loose when the machine is used. Damage to the machine or accidents may be caused as a result.

→ Observe the correct torque specifications in chapter »Screw and bolt tightening torques« on page 69.

The PTO shaft continues turning after it has been switched off

After the PTO shaft drive on the tractor has been switched off, the machine continues to run due to the moment of inertia. Maintain a sufficiently safe distance until all moving parts have come to a complete standstill. Otherwise, damage to the machine and serious or fatal injury may be caused as a result.

Cornering and turning manoeuvres

Centrifugal forces are in operation during cornering. The machine's centre of gravity at the rear of the tractor is displaced. Be aware of the turning radius and the moment of inertia. A driving style which is not adapted to conditions can cause accidents. Accidents with serious or fatal injuries may be caused as a result.

Uncoupling

Increased risk of injury

There is an increased risk of injury when uncoupling the machine from the tractor.

Therefore:



- Switch off the tractor engine, put the parking brake in the park position, remove the ignition key and secure the tractor against rolling away.
- Never stand between the tractor and machine.
- Set the machine down on firm, secure and level ground.
- Ensure that the parking stand is securely locked.
- Place the PTO shaft in the holder provided.
- Secure the machine against rolling away.

Failure to observe these instructions can result in serious or fatal injury.



Care and maintenance

Observe the care and maintenance intervals

Observe the periods specified in the operator's manual for recurrent checks and inspections. If these periods are not observed, damage to the machine and accidents may be caused as a result.

Use original parts

Many components have special properties that are essential for the stability and correct operation of the machine. Only spare parts and accessories supplied by the manufacturer have been tested and approved. Other products may adversely affect the correct operation of the machine and safety. Using non-OEM replacement parts renders the manufacturer's guarantee null and void and frees the manufacturer from all liability.



When performing care and maintenance work:

- Switch off the PTO shaft drive.
- Whenever possible, uncouple the tractor.
- Switch off the tractor engine, put the parking brake in the park position, remove the ignition key and secure the tractor against rolling away.
- Ensure the machine is standing on firm, secure and level ground, and provide additional support, if necessary.
- Secure the machine against rolling away.

Only if these regulations are observed can safe working be ensured during care and maintenance work.

Turn off the electrical supply

Prior to carrying out work on the electrical system, disconnect the system from the power supply. Systems being supplied with electrical power can cause damage to equipment and injury to persons.

Caution when cleaning with a high-pressure cleaner

Exercise caution when cleaning with a high-pressure cleaner. Bearings, seals and pipe unions are not waterproof. In order to prevent damage to the machine, the bearings, seals and pipe unions must not be exposed to direct contact with the high pressure water jets.

No aggressive washing additives

Do not use any aggressive washing additives for cleaning. Uncoated metal surfaces can be damaged.

Before carrying out welding work

Disconnect all electrical connections from the tractor when carrying out welding on the hitched machine. Damage may otherwise be caused to the electrical system.

Retighten all nuts, bolts and screws

All screwed/bolted connections that are loosened during maintenance and repair operations must be retightened. Serious injury and damage to equipment can be caused by loose pin and screwed connections.



Distance from the centre of gravity

Observe the total weight, axle loads, tyre load-bearing capacity and minimum ballast specifications.

The front or rear attachment of machines must not cause the tractor's permissible total weight, its permissible axle load or its tyre load-bearing capacity to be exceeded. In order for steering capability to be maintained, the front axle must bear at least 20 % of the tractor's unladen weight.

By investing some effort in making the calculations you can determine the:

- Total weight
- Axle load
- Tyre load-bearing capacity
- Minimum ballast

For this calculation, the following data is required:

Data from the tractor's operator's manual

- (A) Unladen weight in kg.
- (B) Front axle load in kg.
- (C) Rear axle load in kg.

Take into consideration any further weights, such as water in the tyres, additional equipment etc.

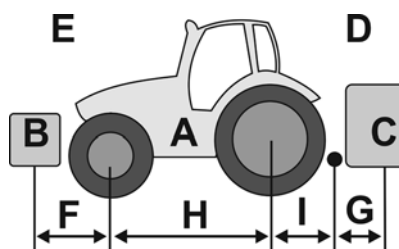

Data from this operator's manual

- (D) Total weight of the machine in the rear attachment. For hitched machines, the supporting load in kg.
- (E) Total weight of the machine in the front attachment in kg.
- (F) Distance between the machine's centre of gravity in the front attachment and front axle midpoint in m.
- (G) Distance between the lower link ball midpoint and the machine's centre of gravity in the rear attachment in m. With hitched machine $G=0$

Data to be measured:

- (H) Tractor's wheel base in m.
- (I) Distance between the rear axle midpoint and the lower link ball midpoint in m.



Calculation

The values (A) to (I) can be inserted in the formulas.

Ballast with front weights

Calculation of the **ballast with front weights** for rear-mounted machines.

$$\text{Front ballast in kg: } \frac{D \cdot (I + G) - (B \cdot H) + (0.2 \cdot A \cdot H)}{F + H}$$

Ballast with rear weights

Calculation of the **ballast with rear weights** for front-mounted machines.

$$\text{Rear ballast in kg: } \frac{(E \cdot F) - (C \cdot H) - (0.45 \cdot A \cdot H)}{H + I + G}$$

Front axle load

Calculating the **actual front axle load (J)**.

$$\text{Front axle load in kg: } \frac{E \cdot (F + H) + (B \cdot H) - D \cdot (I + G)}{H}$$

Total weight

Calculating the **actual total weight (K)**.

$$\text{Total weight in kg: } K = E + A + D$$

Rear axle load

Calculating the **actual rear axle load (L)**.

$$\text{Rear axle load in kg: } L = K - J$$

Tyre load-bearing capacity

Information about the tyre load-bearing capacity of the front and rear wheels can be found in the tyre manufacturer's details.

The front tyre load-bearing capacity for two wheels is equal to twice the permissible tyre load-bearing capacity of a single front wheel. The rear tyre load-bearing capacity for two wheels is equal to twice the permissible tyre load-bearing capacity of a single rear wheel.

Summary

The actual values for the rear axle load must be less than the permissible values given in the tractor's operator's manual. The tyre load-bearing capacity must be greater than the values for the rear axle load given in the operator's manual.

The actual total weight must be less than the permissible total weight given in the tractor's operator's manual. If not, the machine must not be coupled to the tractor.



Further regulations

Observe the regulations

In addition to the safety information listed above, observe the following:

- Regional accident prevention regulations.
- Generally recognised safety regulations, occupational health requirements and road traffic regulations.
- The instructions provided in this operator's manual.
- Standards and instructions relating to operation, maintenance and repair.

Warranty

The warranty and manufacturer's liability will no longer be valid if the instructions provided in the chapter on Safety are not observed, if maintenance is inadequate or faulty, if the machine is used for purposes other than those for which it was intended and if it is overstressed, or if impermissible modifications are made to the machine.

Getting to know the machine

Range of application

This product is classified as replaceable equipment in accordance with EC directive 2006/42/EC.

The machine is a single-wheel rake, which is suitable only for the raking together of mown, stalked material (for example, hay or straw).

Proper use

Any other use, for example, for silo distribution, any form of soil preparation, road sweeping or for the transmission of power to other machines, is not permitted. The manufacturer and dealers are not liable for damage caused by improper use. The risk is borne solely by the user.

Features

Flexible in operation

This single-wheel rake meets all the requirements of modern crop harvesting engineering and, due to its size, is particularly suitable for use on small- and medium-sized areas.

The rake can be hitched to tractors of 20 kW (28 hp) or more.

Extensive equipment

The machine has a low-maintenance gear box and is equipped with 9 or 10 tine supports on each rotor.

Easy changeover from work to transport position

The rake is easily changed over from the work to the transport position.

Designation of components

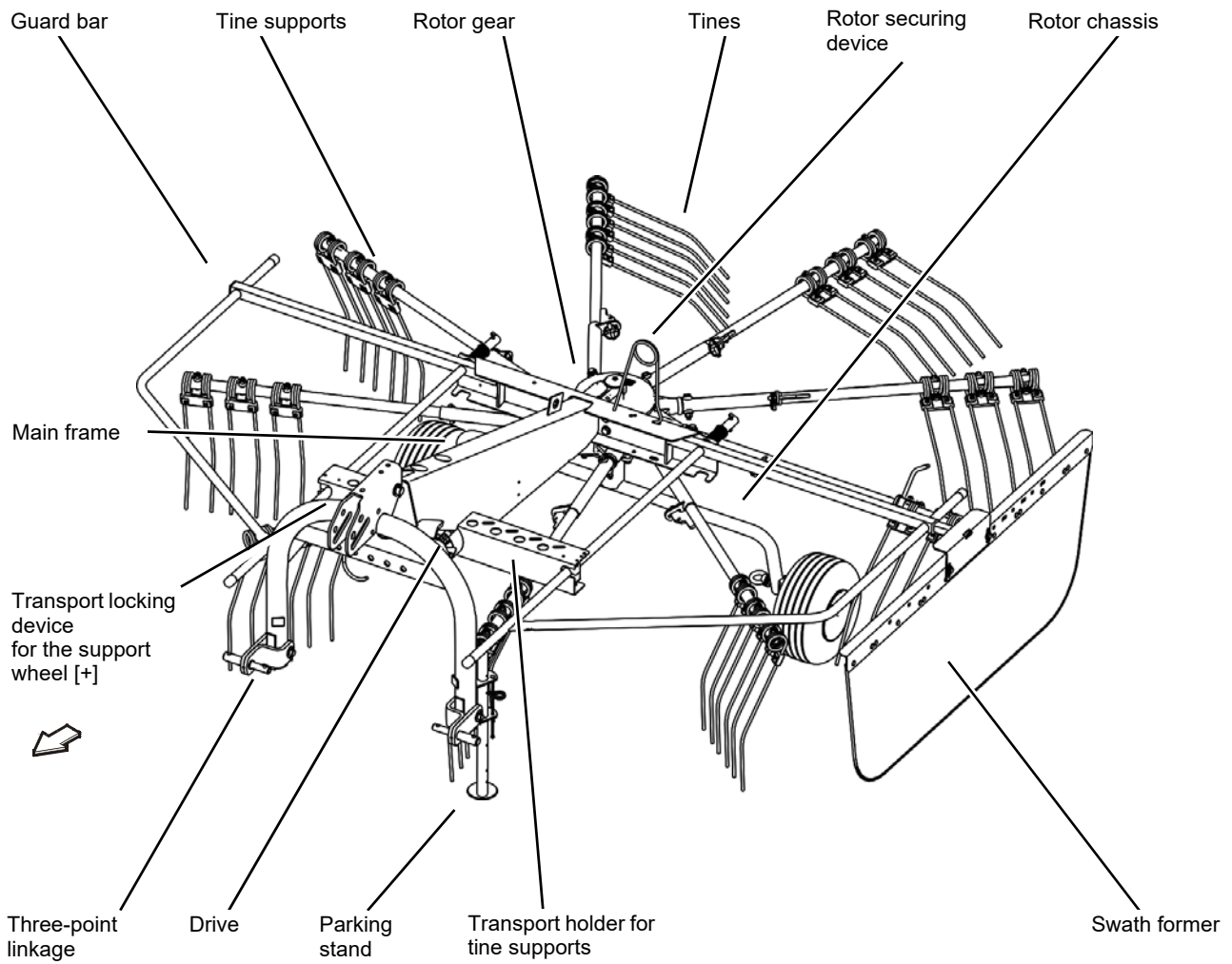

Getting to know the machine

Technical specifications

Dimensions in transport position

Model		VF6589
L_R	Length	3.12 m (10.24 ft)
H_R	Height	1.60 m (5.25 ft)
W_R	Transport width	1.58 m (5.19 ft)
R	Height of bottom reflectors	0.68 m (2.23 ft)
S	Distance between bottom reflectors	0.82 m (2.69 ft)
T	Track	1.47 m (4.83 ft)
D	Distance, machine's centre of gravity	1.47 m (4.83 ft)

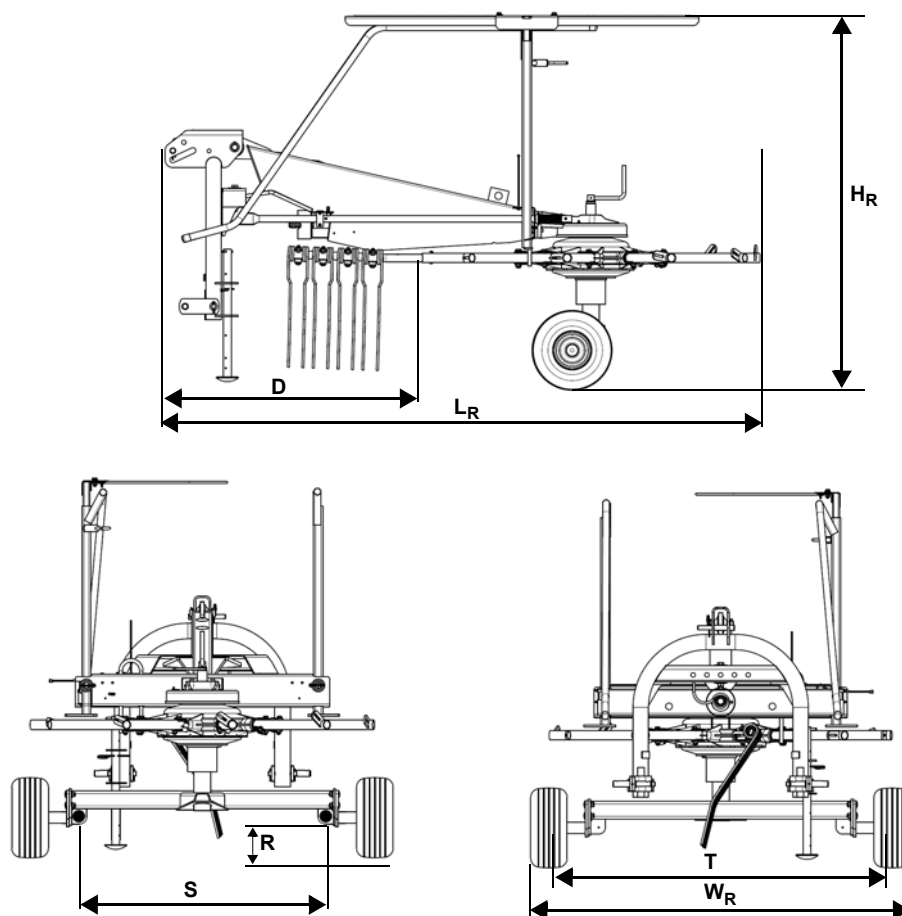

Dimensions in work position

Model		VF6589
L_W	Length	3.12 m (10.24 ft)
W_O	Clearing width	2.50 m (8.21 ft)
W_W	Working width	3.20 m (10.50 ft)

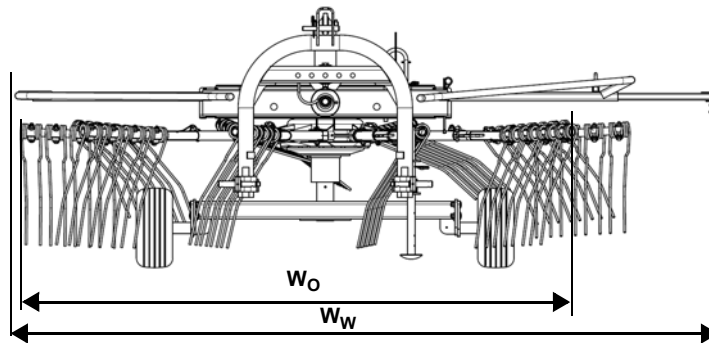
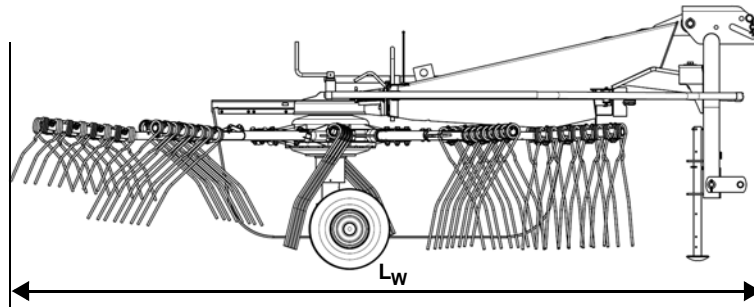

Getting to know the machine

Weights

Model	VF6589
Total weight	320 kg (706 lbs)
Load supported on lower link	50 kg (111 lbs)

Tractor equipment required

Output / connections		
	Minimum output of the tractor	20 kW (28 hp)
	Lighting power supply	12 V, 7-pin plug socket ISO 1724
	Maximum PTO shaft speed	540 rpm
	Lower link	–

Machine equipment

Model		VF6589
Swath deposit		
	Swath former	Standard
Rotors/tine supports/tines		
	Number of rotors	1
	Number of tine supports per rotor	9
	Number of tines per tine support	3
	Removable tine supports	Standard
	Rotor height adjustment	Mechanical
	Tine saver	[+]
	Crank extension	–
Wheels		
	Rotor chassis	15 x 6.00 6 PR
	Tandem axle	[+]
Safety accessories		
	Lighting equipment	[+]
	Warning signs	[+]
PTO shaft		
	PTO shaft	Standard

Measurement of airborne sound emissions

The airborne sound emissions from the machine are below the levels stipulated by machinery directive 2006/42/EC.

- A-weighted sound level in the workplace:
< 70 dB(A)
- Currently C-weighted sound level:
< 63 Pa (130 dB based on 20 µPa)
- A-weighted sound level on the machine:
< 80 dB(A)

Delivery and assembly

Checking the scope of delivery

Delivery is in the fully assembled state

The machine is delivered fully assembled. Using the check list, check the loose parts on delivery. If any parts of the machine have not been fitted or are missing, please contact your dealer.



Do not assemble the machine yourself

Trained personnel are required to assemble the machine. Do not perform assembly work yourself. The following points are required to be met for the machine to be in proper condition:

- Observance of a sequence of work steps.
- Compliance with tolerances and torques.
- Knowledge of work safety during assembly.

Incorrect assembly can result in damage to the machine or accidents.



If parts are missing or have been damaged during transportation, please inform the dealer, importer or manufacturer immediately.

Checklist for parts which were supplied loose	Quantity
PTO shaft for drive	1
Tine supports, CCW delivery	9
Swath former	1
Operator's manual	1
Spare part manual	1
Accessories	See delivery note

Operator's manual

The operator's manual and spare part manual can be found in the document box on the machine.

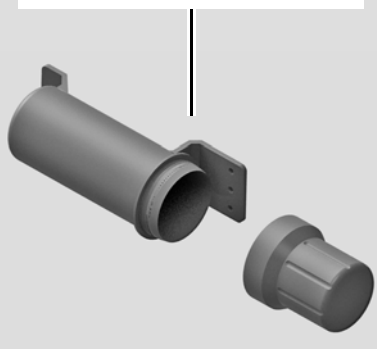

The operator's manual belongs with the machine and must always be kept on board. A document box for the operator's manual and spare part manual is mounted on the main frame.

Length of PTO shaft

The length of the PTO shaft was selected at the factory to suit almost all types of tractor. Only in exceptional cases is a correction of the PTO shaft length required on individual tractors. Check the length of the PTO shaft on each tractor prior to first use.

A manufacturer's operator's manual for the PTO shaft is enclosed. This includes detailed information on the relevant version of the PTO shaft and must be observed.

Safety



Switch off the tractor and secure it

Before you dismount:

- ▶ Lower all implements to the ground.
- ▶ Switch all operating controls to their neutral or park position.
- ▶ Put the tractor's parking brake into the park position. Switch off the tractor.
- ▶ Remove the ignition key.
- ▶ Secure the tractor against rolling away.



An unsecured tractor can run you over or trap you. Otherwise, serious or fatal injury may be caused as a result.



Check the angle of lock

The tractor's PTO shaft has a wide hinge joint, allowing an angle of lock of up to 80°. Make sure that the PTO shaft is not damaged during tight cornering. The machine may be damaged as a result.

Correct length

A PTO shaft that is too long must not be used. Otherwise, damage to the drive bearings on the tractor and machine may be caused as a result.

Checking the length of the PTO shaft

- ▶ Couple the machine to the tractor without the PTO shaft.
- ▶ Lower the tractor's lower link.
- ▶ Set the combination (tractor and machine) to the smallest steering angle.
- ▶ Switch off the tractor engine, put the parking brake in the park position, remove the ignition key and secure the tractor against rolling away.



Delivery and assembly

Shortening the PTO shaft

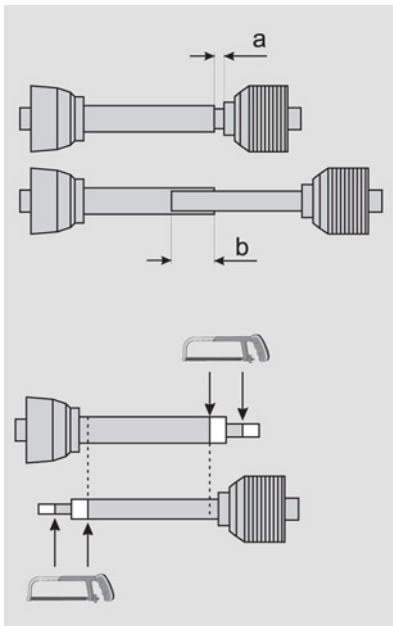

- ▶ Pull the PTO shaft apart and connect one half to the tractor PTO shaft drive and one to the machine and secure them.
- ▶ Place the two shaft halves next to each other and:
 - Check for a minimum of 250 mm (10 in) overlap (b).
 - Check that the PTO shaft does not block at one end (minimum clearance (a) = 20 mm (1 in))
- ▶ Shorten the slide tube and guard tube by the same dimension.
- ▶ Deburr the ends of the tubes.
- ▶ Remove the swarf.
- ▶ Grease the sliding surfaces well.

Fitting the PTO shaft

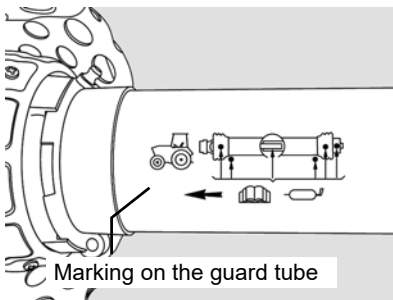

Make sure that you fit the PTO shaft in the correct installation position. There is a marking on the guard tube of the PTO shaft.

- ▶ Check the length of the PTO shaft and shorten it if necessary.
- ▶ Place the PTO shaft onto the PTO stub shaft of the machine.
- ▶ Secure the PTO shaft with a locking pin.

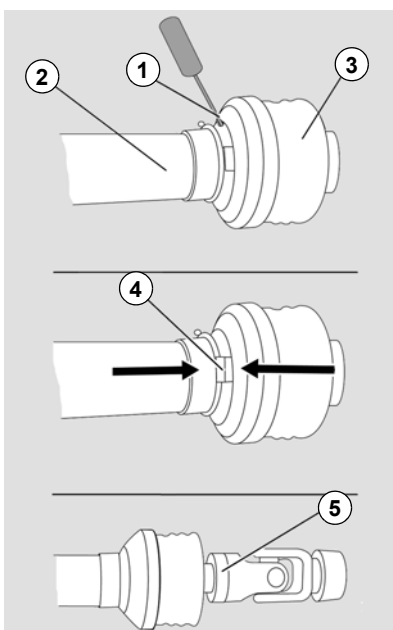

- ▶ Remove the locking screw (1) between the guard tube (2) and the guard cone (3).
- ▶ Twist the guard cone (3) and the guard tube (2) in opposite directions so that the "noses" of the slide ring (4) are positioned directly over the slots on the guard cone (3).
- ▶ Pull the guard cone (3) and guard tube (2) back until the single joint (5) is accessible.
- ▶ Connect the PTO shaft to the machine.
- ▶ Push the guard cone (3) and guard tube (2) back over the single joint (5).
- ▶ Tighten the locking screw (1).
- ▶ Secure the guard cone to the gear box using a jubilee clip.

Safety



Observe the safety information

Disregard for safety information can lead to serious or fatal injury. See chapter »Safety«, page 7.

Increased risk of injury

When the machine is being coupled to the tractor, there is an increased risk of injury. Therefore:

- Never stand between the tractor and machine.
- Secure the tractor against rolling away.
- Actuate the three-point power lift system slowly and carefully.

Failure to observe these instructions can result in serious or fatal injury.

General

The following work steps are described in this section:

- »Coupling the three-point linkage«
- »Inserting the parking stand«
- »Coupling the PTO shaft«
- »Connecting the electrics«

Coupling the machine

Coupling the three-point linkage

The machine is equipped ex-factory for coupling to the three-point linkage of category I and category II tractors.

Adjusting the hitch

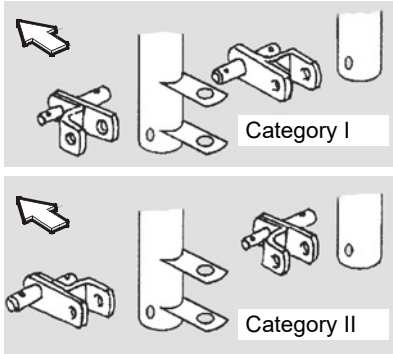

For use on category I tractors, proceed as follows:

- ▶ Remove the split pin on the first clevis of the three-point linkage (cf. illustration).
- ▶ Turn the clevis round 180 degrees.
- ▶ Secure the clevis with a new split pin.
- ▶ Repeat the procedure for the second clevis.

Tractors with quick-release couplings



Follow the instructions for the quick-release coupling

Follow the instructions below for tractors with quick-release couplings. Also note the instructions and warnings in the operator's manual of the tractor manufacturer. If this requirement is ignored, the consequence may be damage to the machine and even life-threatening injuries.

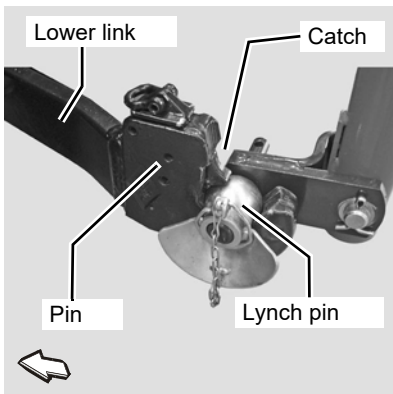

- ▶ Slide guided cone balls suitable for the tractor onto the lower link hitching system of the machine.
- ▶ To couple the machine, raise the lower link until the catch engages.
- ▶ Secure the quick-release coupling with linchpins.
- ▶ Secure the catch with pins.
- ▶ Follow the instructions for »Tractors without quick-release coupling«.

Tractors without quick-release coupling



The following applies to all tractors, with or without quick-release couplings:

- ▶ Reverse the tractor with lower links lowered until the hooks on the lower link are below the machine's hitch pins.
- ▶ Using the hydraulic control device, raise the lower link until the arrester hooks on the lower link engage with the hitch pins.
- ▶ Switch off the tractor engine, put the parking brake in the park position, remove the ignition key and secure the tractor against rolling away.
- ▶ Secure hitch pins for lower link.
- ▶ Insert the parking stand.
 - See »Inserting the parking stand«, page 34.

Coupling the top link

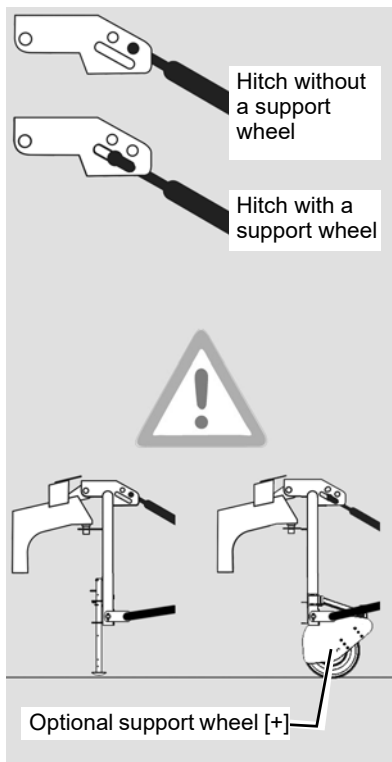

When coupling the top link, ensure that the hitch pin is correctly fitted (see illustration opposite).

- ▶ Please note the following. Otherwise, damage to the machine may be caused as a result:
 - When using the optional support wheel:
 - ▶ Peg the hitch pin in the elongated hole and secure it with a safety splint.
 - Without a support wheel:
 - ▶ Peg the hitch pin in the hole and secure it with a safety splint.
- ▶ Adjust the tractor's top link to the required length and connect to the top link hitch pin.
- ▶ Secure the top link hitch pin using a safety splint.
- ▶ Adjust the lower link such that a uniform ground clearance is maintained.



Please ensure that, where an optional support wheel is used, the hitch pin for the upper link attachment is in the middle of the elongated hole when the machine is lowered. Otherwise, the machine may not be able to handle the unevenness of the ground.

Coupling the machine

Inserting the parking stand

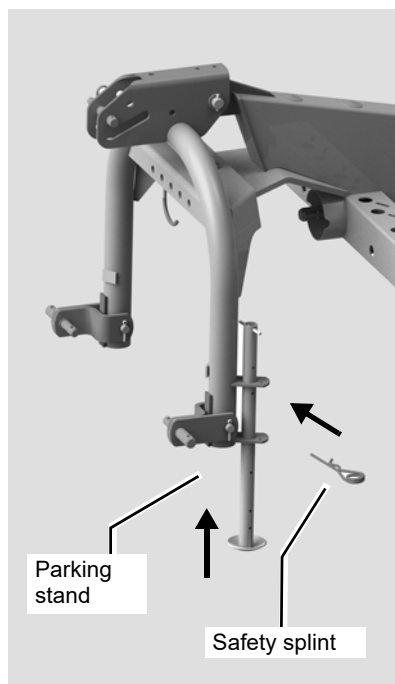

After coupling, insert the parking stand.



- ▶ Switch off the tractor engine, put the parking brake in the park position, remove the ignition key and secure the tractor against rolling away.
- ▶ Pull out the safety splint on the parking stand.
- ▶ Insert the parking stand.
- ▶ Secure the parking stand with the safety splint.

Coupling the PTO shaft

Make sure that you fit the PTO shaft in the correct installation position. There is a marking on the guard tube of the PTO shaft.

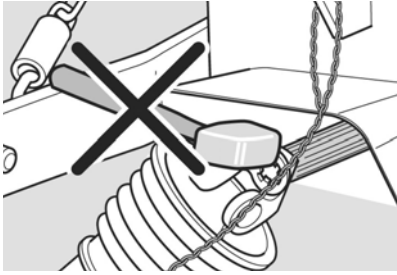

Do not use force

When coupling the PTO shaft, do not use a hammer or any similar tools. Using these types of tool can severely damage the PTO shaft. Otherwise, damage to the machine may be caused as a result.

When coupling the PTO shaft, make sure it is in the correct position.

- ▶ Check whether the PTO shaft must be shortened before coupling.
- ▶ Shorten the PTO shaft if necessary.
→ »Length of PTO shaft«, page 29

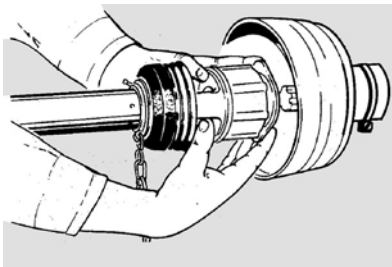
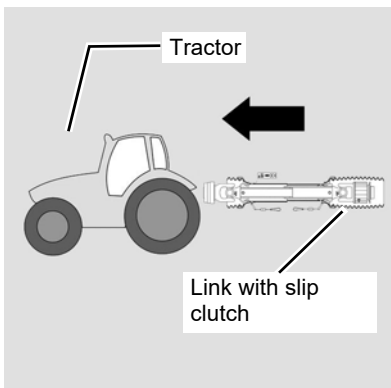

- ▶ Check that the tractor's PTO stub shaft is clean and lubricated.
- ▶ Couple the PTO shaft to the tractor and the machine.
- ▶ Ensure that the PTO shaft is engaged on the shaft ends.
- ▶ Secure the guard tubes so that they cannot rotate at the same time.
- ▶ Couple the link with slip clutch to the machine's PTO stub shaft.

Coupling the machine

Connecting the electrics



Checking the electrical cables

Check the electrical cables. The electrical cables must not chafe or hang loose. Electrical cables that have been torn away or worn through must be replaced. Otherwise, damage to the machine may be caused as a result.

Attach the following electrical cables to the tractor:

Lighting equipment [+]



- ▶ Connect the plug for the 12 V power supply to the 7-pin plug socket on the tractor.

Safety

The following applies to all preparations for operation:

+



Observe the safety information

Disregard for safety information can lead to serious or fatal injury. See chapter »Safety«, page 7.

Secure the machine

Secure the machine against accidental starting and rolling away. Use wheel chocks. The machine must stand on a level, firm and secure surface and be supported during the work, if necessary. Unsecured or non-supported machines can cause accidents. Otherwise, serious or fatal injury may be caused as a result.

No persons in the working area

Ensure that no persons – children in particular – are present in the slewing and working area of the machine. Persons could be caught by the machine within this area. This could result in fatal injury.

Avoid the hazard area

The rotors are considered a hazard area. Do not stand in the hazard area. The rotors may lower or turn. This can lead to serious or fatal injuries.

Remove tine supports

When carrying out adjustment work on the machine, tine supports which hinder work on the machine must be removed. Tine supports that are not removed can cause serious injuries.

Preparing for use

General

The following applies when performing all adjustment work:

- ▶ Check the tyre pressures.
- ▶ Secure the machine.
- ▶ Lower the machine to the work position.
- ▶ Undo appropriate bolts and/or screws.
- ▶ Make the required adjustment.
- ▶ Retighten the bolts.
- ▶ Fit and secure the tine supports.

The following work steps are described in this section:

- »Rotor pitch«
- »Working depth«

Adjusting the machine

The machine is preset at the factory. The following illustration shows an overview of the basic settings. Detailed information can be found on the following pages.

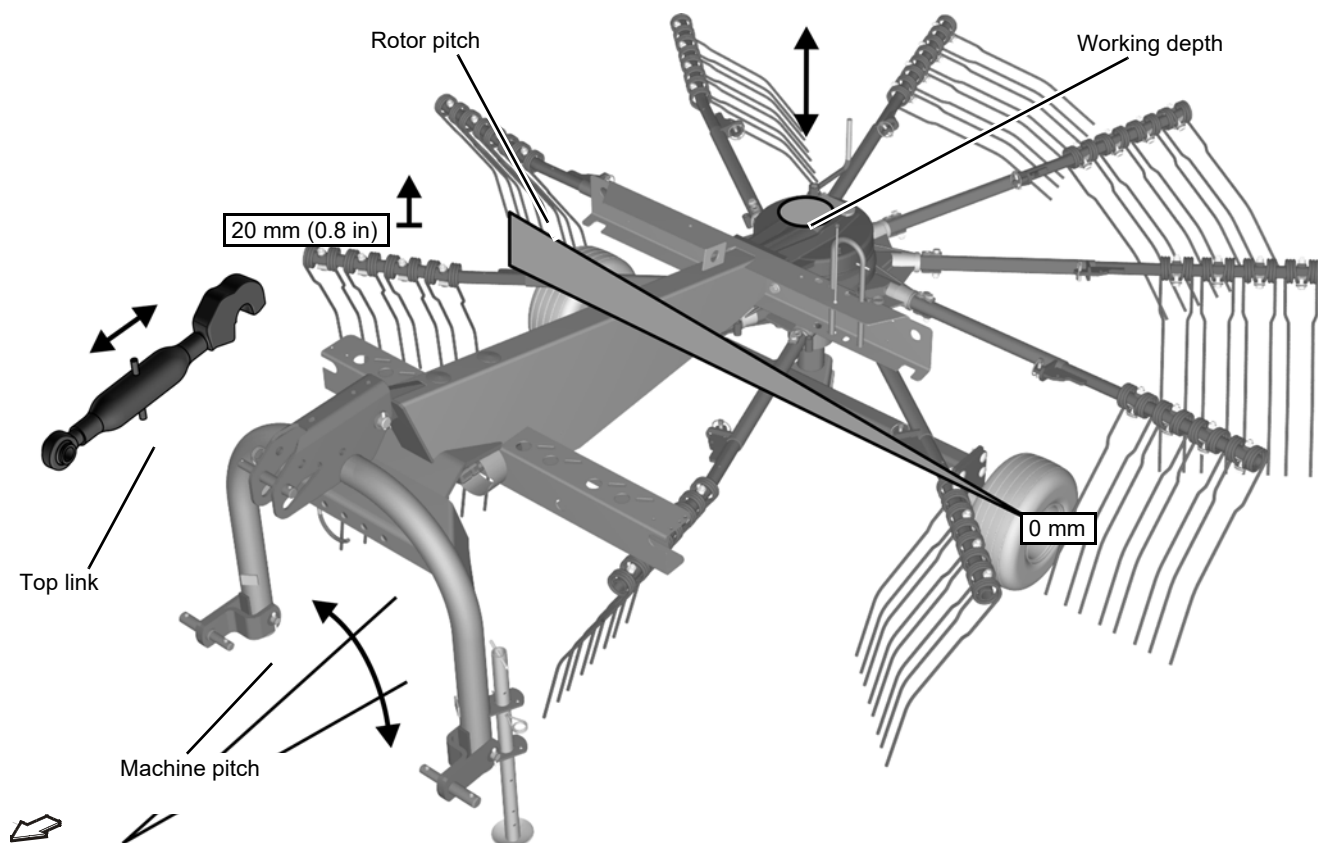

Machine pitch

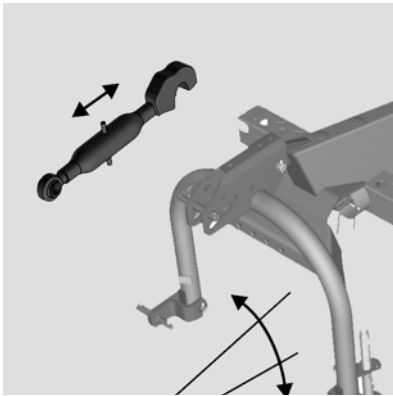

For improved pick-up of the crop, use the top link to incline the machine further to the front.

- ▶ Using the top link, incline the machine further to the front until the crop is picked up cleanly.

Rotor pitch

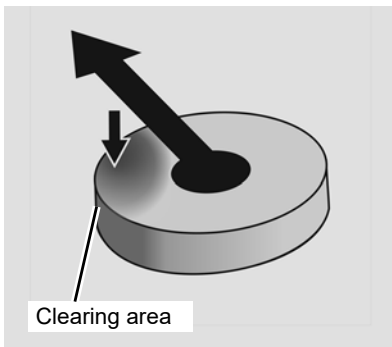

The rotors are inclined at an angle to the chassis so that the crop is picked up in the clearing area. The rotor is already inclined transversely ex-factory. If the crop is not picked up cleanly, the raking quality can be improved by adjusting the rotor pitch.

The rotor pitch is adjusted as follows:

- ▶ Raise the machine to the headland position using the hydraulic control device.
- ▶ Switch off the tractor engine, put the parking brake in the park position, remove the ignition key and secure the tractor against rolling away.
- ▶ Secure the rotors using supports.
- ▶ Remove the tine supports.



The optimum raking quality is achieved when the tines in the front working area and before the crop is deposited have the lowest possible ground clearance (see adjacent illustration).

Preparing for use

Adjusting the rotor pitch

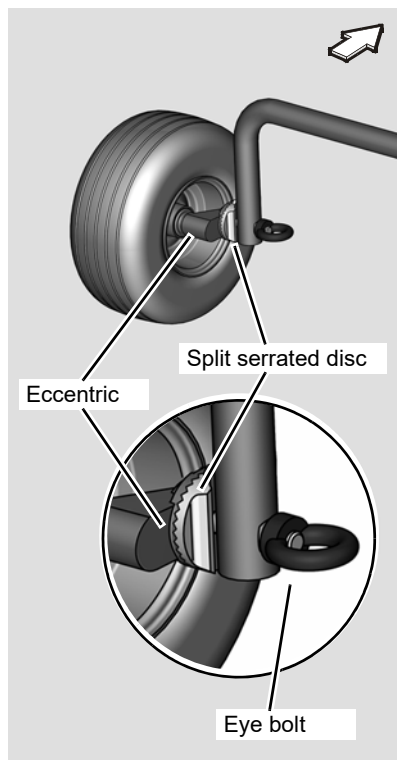

It is possible to adjust the position of the rotors laterally to the direction of travel.

- ▶ Remove the tine supports via the wheel carrier.
- ▶ Undo the eye bolts on the chassis.
- ▶ Adjust the eccentric using the split serrated disc.
- ▶ Securely tighten the eye bolts on the chassis.
- ▶ Fit and secure the tine supports.
- ▶ Check the rotor pitch: the tines in the clearing area should lightly touch the ground.

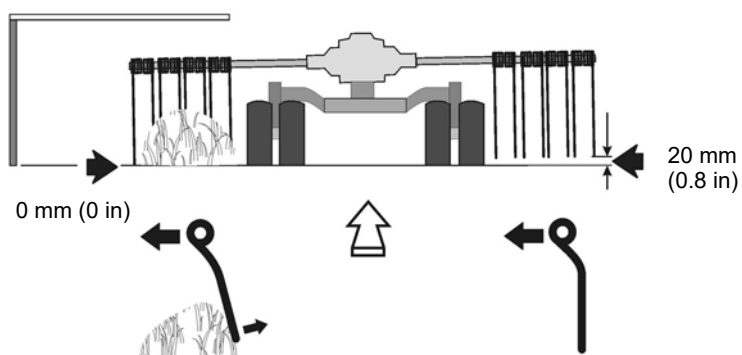

Crop pickup increases the distance between the tines and the ground.



On the side opposite the swath former, the distance between the tines and the ground must be approximately 20 mm (0.8 in) greater than on the swathing side.

Working depth

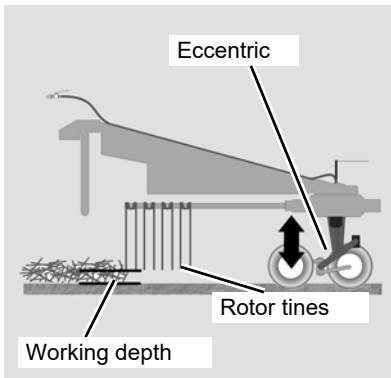

The working depth is manually adjusted on the chassis using an eccentric.

Adjust the working depth as follows:



- ▶ Fully lower the machine using the hydraulic control device.
- ▶ Switch off the tractor engine, put the parking brake in the park position, remove the ignition key and secure the tractor against rolling away.
- ▶ Check the working depth: The tines on the swathing side should slightly touch the ground.

Adjusting the working depth



Never work under suspended loads

Do not carry out work under suspended loads (for example, raised rotors) unless the loads have been secured. Carry out the work only from the outside and between the tine arms. Otherwise, serious injury may be caused as a result.

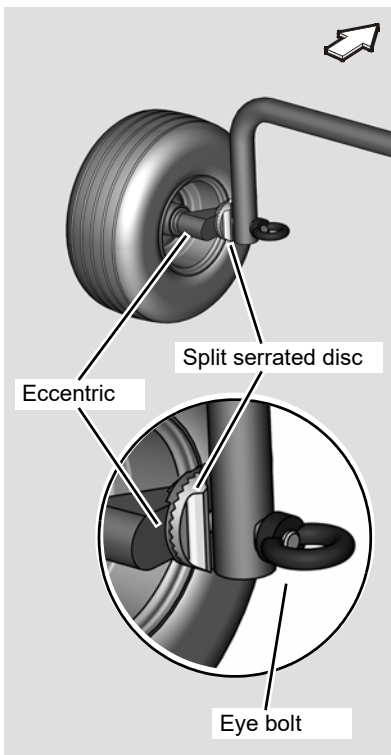

- ▶ Remove the tine supports via the wheel carrier.
- ▶ Undo the eye bolts on the chassis.
- ▶ Adjust the working depth using the split serrated disc on the eccentric.
- ▶ Securely tighten the eye bolts on the chassis.
- ▶ Fit and secure the tine supports.
- ▶ Check the working depth: The tines should slightly touch the ground on the swathing side.



Tines that are set too low will soil the crop. The load on the rotor tines and the drive is increased.

- ▶ Securely retighten the eye bolts on the chassis in the correct position.



The rotor pitch and the tine lifting for model VF6589 can also be adjusted by using different positions for both of the eccentric axes.

Slope locking mechanism [+]

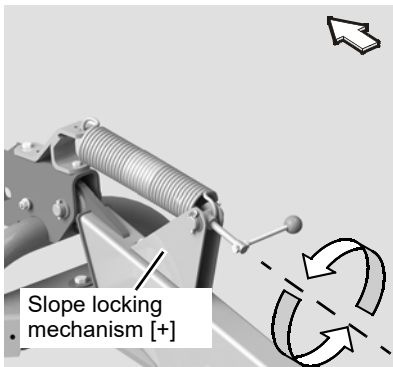

The optional slope locking mechanism improves ground contact when travelling on hills and ensures that the rotor gathers the crop reliably, even on hillside locations.

Slope locking mechanism active:

- ▶ Fully screw in the spindle.

Slope locking mechanism off:

- ▶ Unscrew the spindle until the spring is relieved of tension.

Safety

Before transporting the machine on public roads, please read the following safety information. Compliance is mandatory and will help you to avoid accidents.



Observe the safety information

Disregard for safety information can lead to serious or fatal injury. See chapter »Safety«, page 7.

Ensuring road safety

The machine must conform to current national traffic regulations if you intend to drive with it on public roads. Ensure the following:

- Lighting, warning and protective equipment must be fitted.
- The permissible transport widths and weights, axle loads, tyre load-bearing capacities, laden weights and national speed restrictions must be complied with.
- The maximum permissible road transport speed must be complied with, but not exceed 50 km/h (30 mph).
- The machine should only be hitched to agricultural or forestry tractors.
- The empty weight of the tractor must be greater than the weight of the machine.

The driver and keeper of the vehicle are liable should these conditions not be observed.

Road transport

Prior to road transport

When driving on public roads, the machine must be in the transport position.

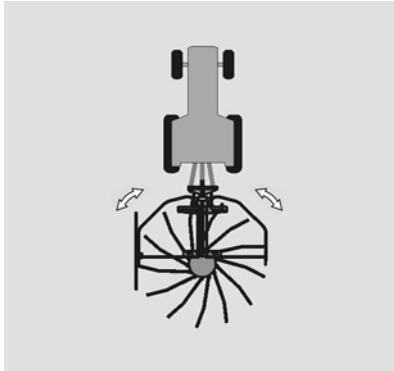

Clean the machine before travelling on the road

Before travelling on the road, remove all coarse dirt, crop residues and clods of earth from the machine and clean it. Crops or dirt that drop onto the road can cause slippery road conditions. This could cause traffic accidents and accidents with fatal consequences.

Observe the contour of the terrain

Move the machine onto ground that is as flat as possible before changing from the work position to the transport position. Avoid inclines on which the combination (tractor and machine) could slip or overturn. There is an increased risk of tipping and injury in a position at right angles to the direction of the slope.

To prepare the machine for road transport, carry out the following steps:

- ▶ »Folding in the guard bar«
- ▶ »Removing the tine supports«
- ▶ »Folding the machine into the transport position«
- ▶ »Locking the transport locking device for the support wheel [+]
«
- ▶ »Checking the machine«

Folding in the guard bar

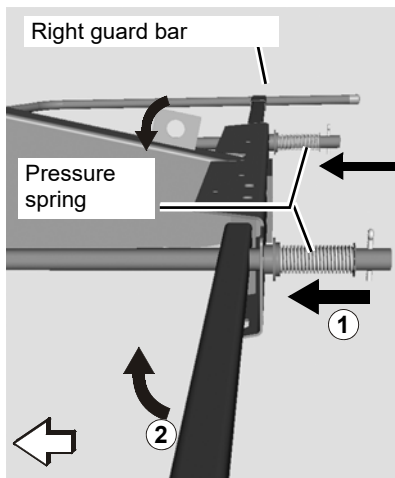

No persons within the slewing range

There is an acute risk of injury within the slewing range from machine parts which are slewing or folding. Otherwise, serious or fatal injury may be caused as a result.

Before removing the tine supports, move all the protective devices around the rotors from the work to the transport position, and lock them in place. Fold in the guard bar as follows:

- ▶ Using the single-acting hydraulic control device, lower the machine to the work position.
- ▶ Switch off the tractor engine, put the parking brake in the park position, remove the ignition key and secure the tractor against rolling away.
- ▶ Fully insert the swath former.
- ▶ Pull the guard bar forwards in relation to the direction of travel and hold it.
- ▶ Fold the guard bar through 90° and engage it in the latch for the transport position.



Road transport

Removing the tine supports

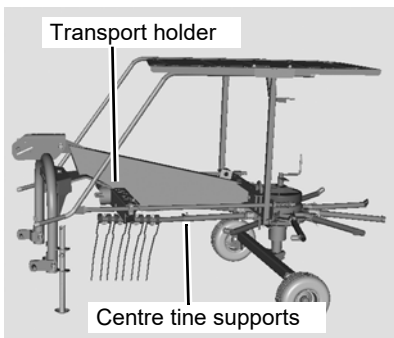
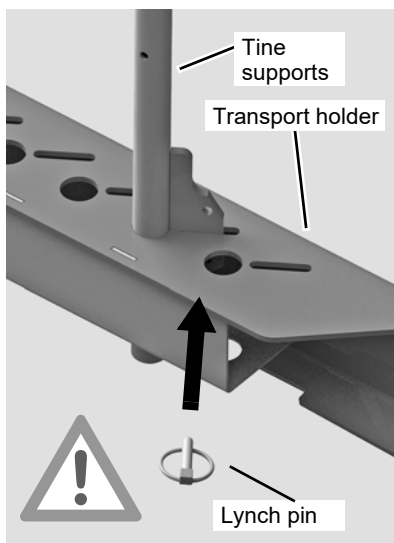
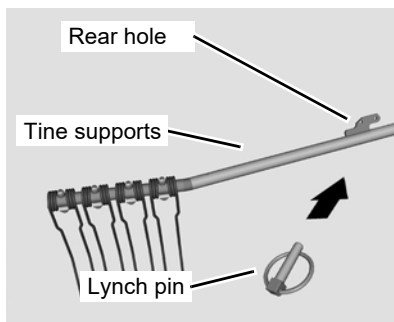

For road transport, all tine supports (with the exception of the centre tine supports) are removed and stowed in the transport holder.

- ▶ Remove any crop and coarse dirt.
- ▶ Loosen the lynch pin on the tine support.
- ▶ Take the tine supports off the rotor and put into the transport holder.

- ▶ Insert the tine support into the transport holder.
- ▶ Secure the tine supports with lynch pins.



The centre tine supports remain on the rotor.

Securing the rotor

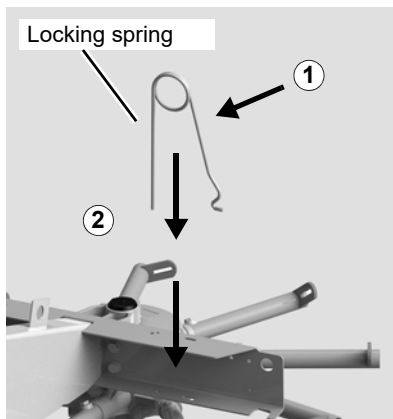

Secure the rotor against turning using the locking spring.

- ▶ Press the locking spring together and slide it through the holes on the frame.
- ▶ When doing so, ensure that the locking spring engages in the lower section of the frame, and secures the rotor onto the tine arm.

Folding the machine into the transport position

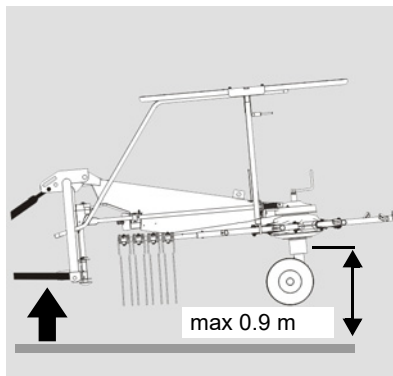

- ▶ Raise the tractor's lower link until it reaches the transport position.



Do not raise the machine beyond the maximum permitted reflector height.

Road transport

Locking the transport locking device for the support wheel [+]

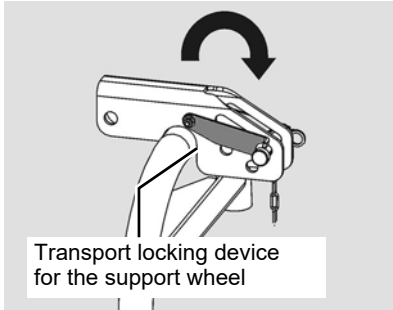

Lock the transport locking device

When transporting a raised machine, the transport locking device must be locked. Otherwise, damage to the machine may be caused as a result.

For the optional support wheel [+], secure the top link hitch pin.

- ▶ Lock the support wheel transport locking device.



Remove the transport locking device for the support wheel before putting the machine into operation. Otherwise, damage to the machine may be caused as a result.

Road transport



Follow the instructions below for road transport. There is otherwise the risk of traffic accidents and accidents with fatal consequences.

- ▶ Before pulling away, check the immediate vicinity. Always make sure that you have a clear field of vision and, in particular, look out for children within the operating area of the machine.
- ▶ When the vehicle is in motion, lock the control devices on tractor.
- ▶ Do not transport people or objects on the machine.
- ▶ Adjust your speed to road conditions.
- ▶ Do not exceed a maximum speed of 50 km/h (30 mph). Comply with the national speed limits.
- ▶ Ensure sufficient steering and braking capability. Driving characteristics, steering, and braking capability are all influenced if the machine is coupled (increased braking distance as a result of greater inertia).
- ▶ There is a danger of tipping on slopes and if corners are taken too fast.

Checking the machine

Prior to driving on the road, check the machine against the check list:



- Guard bar folded in?
- Tractor control system for hydraulics is "OFF"?
- Tractor's PTO shaft drive is "OFF"?
- Locks checked for firm seating?
- Tyre pressures correct?
- Lower link engaged and secured at the sides?
- Hitch pins secured?
- Machine in transport position?
- Transport locking device locked?
- Parking stand secured in the transport holder?
- Crop residues and dirt removed?
- Lighting cables routed so that they are not strained and cannot be caught by the tractor's wheels when cornering?
- Lighting equipment in good working order?

Safety

The following applies for all preparations on the field:



Observe the safety information

Disregard for safety information can lead to serious or fatal injury. See chapter »Safety«, page 7.

Switch off the tractor and secure it

Before you dismount:

- ▶ Switch off the PTO shaft drive.
- ▶ Lower all implements to the ground.
- ▶ Switch all operating controls to their neutral or park position.
- ▶ Put the tractor's parking brake into the park position.
- ▶ Switch off the tractor.
- ▶ Remove the ignition key.
- ▶ Secure the tractor against rolling away.

An unsecured tractor can run you over or trap you. Otherwise, serious or fatal injury may be caused as a result.

Avoid the hazard area

The rotors are considered a hazard area. Do not stand in the hazard area. The rotors may lower or turn. Serious or fatal injury may be caused as a result.

Secure the machine

Secure the machine against accidental starting and rolling away. Use wheel chocks. The machine must stand on a level, firm and secure surface and be supported during the work, if necessary. Unsecured or non-supported machines can cause accidents. Otherwise, serious or fatal injury may be caused as a result.

No persons in the working area

Ensure that no persons – children in particular – are present in the slewing and working area of the machine. Persons could be caught by the machine within this area. Fatal injury may be caused as a result.

General

The following work steps are described in this section:

- »Folding the machine into the work position«
- »Fitting the tine supports«
- »Folding out the guard bar«
- »Adjusting the swath former«

Folding the machine into the work position

After road transport, the machine is brought into the work position on the field.

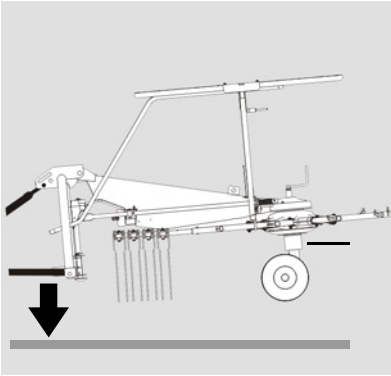

▶ Switch on the tractor.

▶ Lower the lower link until the machine rests on the wheels.



▶ Switch off the tractor engine, put the parking brake in the park position, remove the ignition key and secure the tractor against rolling away.

▶ Observe the instructions in chapter »Preparing for use«, section »Working depth« on page 41.

Preparations on the field

Releasing the rotor

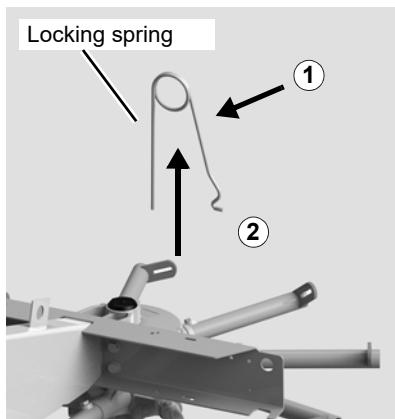

Remove the locking spring on the rotor.

- ▶ Press the locking spring together and remove it so that the rotor can turn.
- ▶ Locking spring

Unlocking the transport locking device for the support wheel [+]

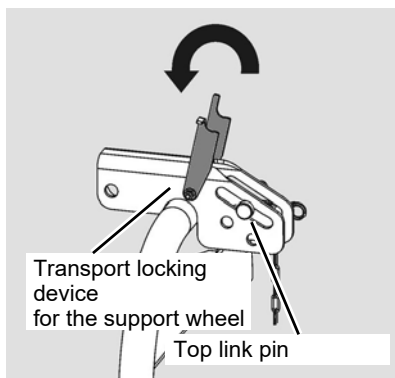

- ▶ Unlock the transport locking device for the support wheel.



In the work position, the top link pin must be fitted centrally in the elongated hole, so that the machine is able to adapt to the unevenness of the ground.

Basic settings

Fitting the tine supports

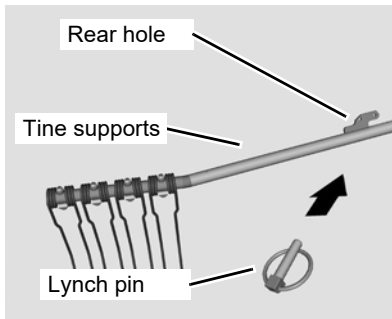

- ▶ Remove the tine supports from the transport holder.
- ▶ Attach the tine supports to the bushed bearing tube and secure with lynch pins.

Preparations on the field

Folding out the guard bar



No persons within the slewing range

There is an acute risk of injury within the slewing range from machine parts which are slewing or folding. Otherwise, serious or fatal injury may be caused as a result.

After the tine supports have been fitted, all protective devices must be moved from transport to work position. Fold out the guard bar as follows:



- ▶ Switch off the tractor engine, put the parking brake in the park position, remove the ignition key and secure the tractor against rolling away.
- ▶ Pull the guard bar forwards in relation to the direction of travel and hold it.
- ▶ Fold the guard bar through 90° to the work position.
- ▶ In park position, fit the safety splint* on the support.

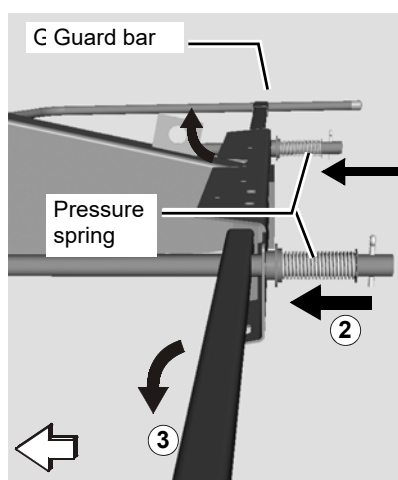

Adjusting the swath former

The swath former is folded into the correct position when changing from the transport to the work position.

Adjusting the swath former in relation to the direction of travel

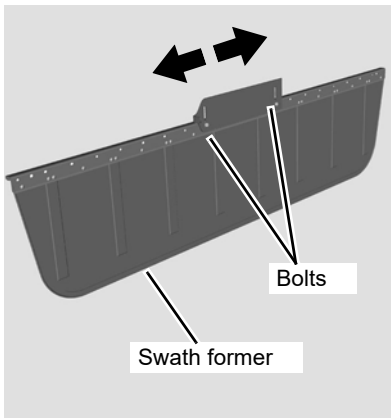

It is possible to adjust the direction of travel of the swath former as follows:

- ▶ Remove the bolts.
- ▶ Move the swath former into the desired position.
- ▶ Fit the bolts and tighten them in the new position.

Adjusting the swath former's height

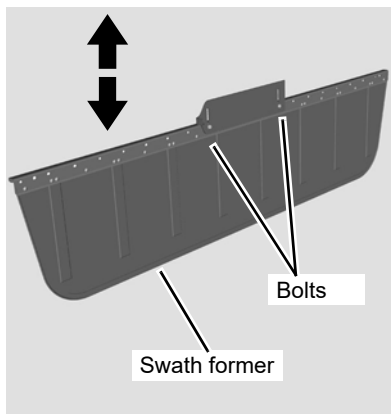

It is possible to adjust the height of the swath former as follows:

- ▶ Loosen the screws.
- ▶ Adjust the height of the swath former.
- ▶ Tighten the bolts in the new position.

Adjusting the swath width

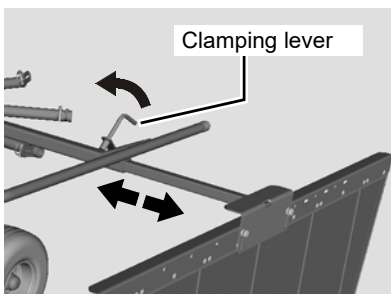

The swath width can be adjusted as follows:

- ▶ Release the clamping lever on the swath former.
- ▶ Pull out or push in swath former to the desired width.
- ▶ Refasten and secure the clamping lever.

Safety



Observe the safety information

Disregard for safety information can lead to serious or fatal injury. See chapter »Safety«, page 7.

No riding on the machine

Persons or objects must never be transported on the machine. Carrying passengers – particularly children – on the machine is life-threatening and prohibited. Serious or fatal injury may be caused as a result.

No persons in the working area

Ensure that no persons – children in particular – are present in the slewing and working area of the machine. Persons could be caught by the machine within this area. Fatal injury may be caused as a result.

Maximum PTO stub shaft speed 540 rpm

The PTO stub shaft speed must not exceed 540 rpm and must be adapted to the condition of the crop. Higher revolution rates can cause damage to the machine.

Only allow the PTO shaft clutch to respond for a short time

Do not allow the slip clutch to respond for longer than 3 seconds. If the clutch responds for a longer period of time, it will become worn and the disconnect torque will drop.

Do not compress the PTO shaft

The PTO shaft between the tractor and machine must not be compressed when in the work position or transport position. If compressed, PTO shafts can cause damage to the machine and tractor.

Observe the contour of the terrain

Pay even more attention when driving on an incline. Avoid inclines on which the combination (tractor and machine) could slip or overturn. There is an increased risk of tipping and injury in a position at right angles to the direction of the slope.

Changes in the centre of gravity

When in work position, the machine's centre of gravity changes. Pay even more attention when driving on an incline. Avoid inclines on which the combination (tractor and machine) could slip or overturn. There is an increased risk of tipping and injury in a position at right angles to the direction of the slope.

General

The following work steps are described in this section:

- »Crop processing«
- »Driving on headlands«



Suitable working speeds

Select a driving speed (approx. 4 to 12 km/h / 2.5 to 7.5 mph) at which the crop is picked up cleanly and completely. The working speed depends on the machine settings and the particular crop.

Swath width

The swath width depends on working width, working speed, tine lifting settings and transverse rotor pitch as well as crop condition.

Crop processing

The following methods of crop deposit are possible with this machine:

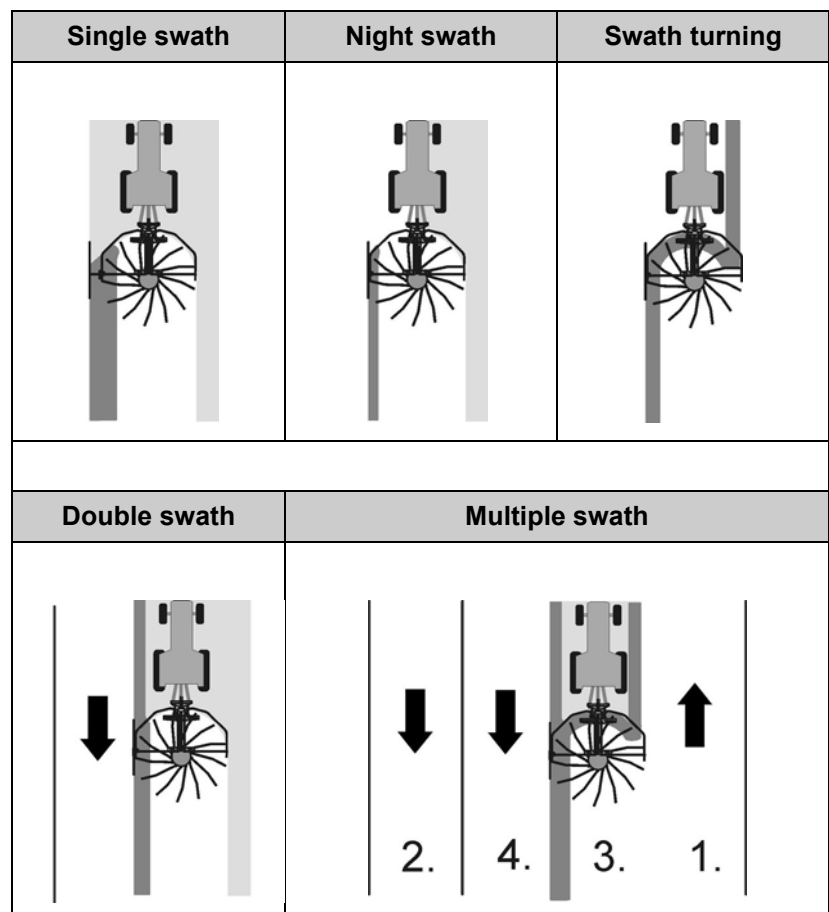

Operation

Swathing



No persons in the working area

Ensure that no persons – children in particular – are present in the slewing and working area of the machine. Persons could be caught by the machine within this area. Fatal injury may be caused as a result.

Requirements

The machine is set correctly as follows:



- Swath former adjusted.
- Tine supports attached and secured.
- Rotor securing implement on the rotor released.
- Tractor's lower links set to floating position.
- Adjust the lowering speed for the tractor hydraulics so that the machine is not damaged while setting it down.
- Machine in work position.

Starting work



- ▶ Switch on the tractor.
- ▶ Check that there is nobody in the working area of the machine.

Switching on the PTO shaft drive



- ▶ Switch on the PTO shaft at a low engine speed.
- ▶ Slowly increase the speed. Do not exceed the maximum speed of 540 rpm.
- ▶ Select a driving speed at which the crop is picked up cleanly and completely.



- Start swathing at the edge of the field and at headlands to avoid subsequently driving over the crop.
- The slip clutch of the machine may also respond at low speed if resistance is increased due to excess crop or obstacles.
- Adapt the PTO shaft speed to the crop processing requirements.

Working speed



Avoid crossing over swathes

As a general rule, avoid crossing over swathes. The crop is distributed unevenly and the machine is subjected to abrupt stresses. Otherwise, damage to the machine may be caused as a result.

Allow ample space when driving around obstacles

Obstacles must be circumnavigated in good time and at a distance. Due to the large width and length of the machine, it reacts slowly and tends to overrun. Otherwise, damage to the machine may be caused as a result.

A constant working speed is essential for uniform crop processing. The working speed should be set between 4 and 12 km/h (between 2.5 and 7.5 mph). The working speed depends on ground and crop conditions.

- ▶ Select a working speed at which the crop is picked up cleanly and completely.

Driving on headlands



Observe the contour of the terrain

Pay even more attention when driving on an incline. Avoid inclines on which the combination (tractor and machine) could slip or overturn. There is an increased risk of tipping and injury in a position at right angles to the direction of the slope.

Observe the slewing range

The rear wheels of the tractor must not come into contact with the drawbar or the attachment carrier when cornering. This may happen when turning sharply. Unsuitable driving behaviour can cause serious damage.

Do not fully raise the machine

Do not fully raise the machine while in the headland. Otherwise, damage to the machine may be caused as a result.

Manoeuvring which involves tight turns on the field must only be performed at walking speed.

The rotor can be raised for crossing swaths that have already been harvested.

- ▶ Raise the machine to the headland position using the tractor's lower link control system.
- ▶ Lower the machine again at the adjusted lowering speed, in order to create a new swath.

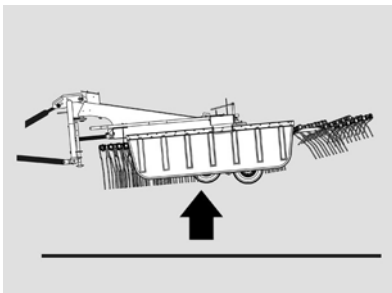

Ensure that the lowering speed of the tractor hydraulics is adjusted so that the machine is not damaged while setting it down.

Safety

The following applies to all cleaning and care work:



Observe the safety information

Disregard for safety information can lead to serious or fatal injury. See chapter »Safety«, page 7.



Secure the machine

- Switch off the PTO shaft drive.
- Depressurise the hydraulic system.
- Whenever possible, uncouple the tractor.
- Switch all operating controls to their neutral or park position.
- Put the tractor's parking brake into the park position.
- Switch off the tractor and remove the ignition key.
- Ensure the machine is standing on firm, secure and level ground, and provide additional support, if necessary.
- Secure the machine against rolling away.



Only if these regulations are observed can safe working be ensured during care and maintenance work. Unsecured or non-supported machines can cause accidents.

No persons in the working area

Ensure that no persons – children in particular – are present in the slewing and working area of the machine. Persons could be caught by the machine within this area. Fatal injury may be caused as a result.

Do not clean bearings or hydraulic parts with high-pressure cleaners

Do not clean bearings or hydraulic parts with high pressure cleaners. The high-pressure cleaner removes the grease film from the bare metal surfaces. Metal surfaces treated in this way can corrode. After each cleaning procedure, lubricate the bearing points and grease uncoated parts.

Clean the bearings and hydraulic parts with care

Exercise caution when cleaning with a high-pressure cleaner. Bearings, seals and pipe unions are not waterproof. In order to prevent damage to the machine, the bearings, seals and pipe unions must not be exposed to direct contact with the high pressure water jets.

Cleaning and care

General

The following work steps are described in this section:

- »Cleaning«
- »Care«

Cleaning



- ▶ Switch off the tractor PTO shaft drive.
- ▶ Using the hydraulic control device, fold the machine into its work position.
- ▶ Leave the machine coupled to the tractor's lower links.
- ▶ Lock the hydraulic control device.



- ▶ Switch off the tractor engine, put the parking brake in the park position, remove the ignition key and secure the tractor against rolling away.
- ▶ Do not clean the bearings and piston rods of hydraulic cylinders using a high-pressure cleaner.
- ▶ After each use, clean the machine of any coarse dirt and crop residue.

After cleaning

- ▶ Lubricate all bearings after cleaning.
→ Observe the chapter »Maintenance« and the following pages.
- ▶ Replace missing warning signs and stickers.

Care

For a long service life, we recommend the following:

- ▶ Apply a protective layer of oil to all uncoated work tools. Only use approved, biodegradable oil, e.g. rapeseed oil.
- ▶ Repair any paint damage.

Setting down the machine in a secure position

When setting down and parking the machine, special safety precautions have to be observed:

**Observe the safety information**

Disregard for safety information can lead to serious or fatal injury. See chapter »Safety«, page 7.

Keep children away from the machine

Forbid children from playing on or around the machine. Select a parking area to which no unauthorised persons have direct access. Metal edges and machine work tools can cause serious injury.

Make sure the machine is standing level

Before changing from the transport to the work position (and vice versa), make sure the machine is standing level. The machine could roll away, particularly on hillside locations. Damage to the machine and serious or fatal injury may be caused as a result.

General

The machine must be uncoupled in the reverse order to that in which it was coupled.







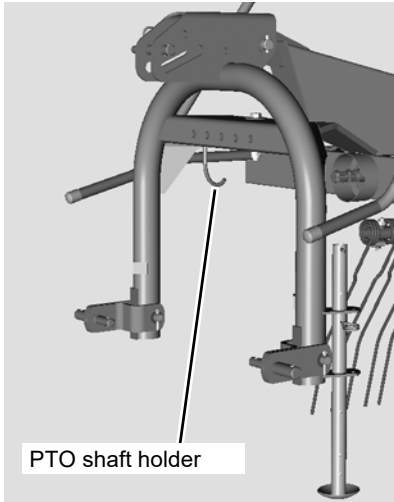





- »Uncoupling the machine«
- »After the end of the season«

Parking and storage

Uncoupling the machine



To uncouple the machine from the tractor, proceed as follows:

-  ▶ Switch off the tractor PTO shaft drive.
-  ▶ Set the machine down on a firm, level surface and lower it to the work position.
-  ▶ Switch off the tractor engine, put the parking brake in the park position, remove the ignition key and secure the tractor against rolling away.
-  ▶ Secure the machine against rolling away.
-  ▶ Pull off the PTO shaft and place it on the holder provided.
-  ▶ Disconnect the plugs for the lighting.
-  ▶ Lower the parking stand and secure with pins.
-  ▶ Wind the electrical cables onto the hook.
-  ▶ Switch on the tractor.
-  ▶ Disconnect the tractor's top link from the machine.
-  ▶ Release the retainer of the lower link guided cone ball to clear the hitch pin on the machine.
-  ▶ Drive the tractor forward with the lower links lowered.
-  ▶ Switch off the tractor engine, put the parking brake in the park position, remove the ignition key and secure the tractor against rolling away.

After the end of the season

After the end of the season and if the machine is to be stored for a long period of time, perform the following work:

- ▶ Clean the machine thoroughly.
- ▶ Check all the screw joints and tighten the screws.
 - Observe the correct torque specifications in chapter »Screw and bolt tightening torques« on page 69.
- ▶ Repair or replace any damaged components.
- ▶ Repair any paint damage.
- ▶ Lubricate the machine in accordance with the lubrication schedule.
- ▶ Check the tyre pressures.
- ▶ Replace missing warning signs and stickers.

Safety

The following applies to all servicing work:



Observe the safety information

Disregard for safety information can lead to serious or fatal injury. See chapter »Safety«, page 7.

Requirements for maintenance work

Only perform the maintenance operations if you have the required expert knowledge and suitable tools. The absence of technical knowledge or suitable tools can cause accidents and injuries.

Protect the machine against unintended starting

The following conditions must be observed for carrying out repairs and maintenance work and rectifying malfunctions on the machine when it is coupled:



- Switch off the PTO shaft drive.
- Switch all operating controls to the neutral or park position.
- Put the tractor's parking brake into the park position.



- Switch off the tractor engine, put the parking brake in the park position, remove the ignition key and secure the tractor against rolling away.
- Ensure the machine is standing on firm, secure and level ground, and provide additional support, if necessary.
- Secure the machine against rolling away.

Serious accidents may be caused if the machine starts accidentally.

Use OEM replacement parts

Many components have special properties that are essential for the stability and correct operation of the machine. Only spare parts and accessories supplied by the manufacturer have been tested and approved. Other products may adversely affect the correct operation of the machine and safety. The use of non-OEM replacement parts renders the manufacturer's guarantee null and void and frees the manufacturer from all liability.

Secure moving parts

Moving parts must be secured with lifting gear against sliding, folding or swivelling. Otherwise, serious injury to persons or damage to the machine may be caused as a result.

Disconnect electrical connections before performing welding work

Disconnect all electrical connections from the tractor when carrying out welding on the hitched machine. Otherwise, electrical and hydraulic systems may be damaged as a result.

Maintenance

Protective measures when handling oils or lubricants

Additives in oils and lubricants may have adverse effects on health. As marking in accordance with the hazardous goods regulation is not necessary, please always ensure the following:



Avoid skin contact

Avoid skin contact with these materials. Protect your skin by means of protective skin cream or oil-resistant gloves. Contact can result in skin damage.

Do not use oils for cleaning

Do not use oils or lubricants to clean your hands. Swarf and abraded material in these materials can also result in injuries.

Change out of soiled clothing

Change out of clothing that is heavily soiled with oil as soon as possible. Oils can be hazardous to your health.



- Used oil must be collected and disposed of.
- If the skin is damaged by oil or lubricant, seek medical advice immediately.

General

This information relates to general servicing work. For all servicing work, the machine must be locked in the work position. If, in exceptional cases, the transport position is required for maintenance work, refer to the relevant instructions for the work.

- ▶ Lower the machine to the work position.
- ▶ Secure the machine against rolling away.

Direction and rotary direction

Direction information (right, left, front, rear) is given in relation to the direction of travel.

Rotary direction is defined as follows:

- Rotary direction right = clockwise.
- Rotary direction left = counterclockwise.
- Rotation about a vertical axis, viewed from top to bottom.
- Rotation about a horizontal axis, viewed at right angles to the direction of travel, from left to right.
- The rotation of screws and nuts, etc. is always viewed from the operating side.

Maintenance terms

Listed in this table are short explanations of the most important maintenance terms.

Task	Explanation
Greasing	Apply grease to the slide surfaces using a brush.
Lubrication	One or two presses of the grease gun, unless specified otherwise.
Oiling	Unless specified otherwise, use only plant-based oils, such as rapeseed oils. The use of used oil will endanger your health and is also strictly prohibited.
Replacement	Replace the appropriate part in accordance with the instruction in the Maintenance chapter.
Inspection	Check the tyre pressures, adjustment dimensions and seal tightness as required, and replace any worn parts or seals.
Observe the maintenance intervals	The specifications relate to an average usage of the machine. If subjected to heavier duty (e.g. by contracting companies), select the maintenance intervals to be shorter. Also, for extreme working conditions (for example heavy dust creation), shorter maintenance intervals are possible.

Lubricant

Lubricant used on this machine must meet the following requirements:

Lubricant	Specifications
Gear oil	SAE 90 API-GL-4 or 5
e.g.: KUBOTA HEAVY DUTY 80W-90 GEAR OIL	
Grease	NLGI GC/lbs
e.g.: KUBOTA Polyurea Grease	

Maintenance

Maintenance intervals

	After 5 hours of operation	Daily	After 20 hours of operation	After 30 hours of operation	After 250 hours of operation	Once per season	After heavy use	As required	In case of wear	Lubrication	Greasing	Inspection	Replacement	Cleaning	Page
General															
All screws	●					●		●							69
Visual inspection		●					●					●			
Bearings						●	●			●					71
Air pressure		●						●				●			74
Lighting equipment		●				●		●				●		●	
PTO shafts															
Single joints						●	●			●					71
PTO shaft guard						●				●		●			73
Profile section tube						●					●				73
Gearbox															
Rotor gear								●				●			74

Screwed connections

On this machine, bolts with a minimum quality of "8.8" (can be seen on the bolt head) are used.

Tightening screws

All bolts must be retightened:

- After the first 5 hours of operation.
- According to the frequency of use.
- At least once a season.

Screw and bolt tightening torques

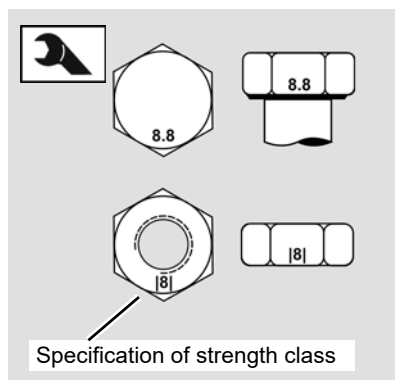

Use the correct screw and bolt tightening torques

Securely tighten screws, nuts and bolts to the specified torques. Otherwise, damage to the machine and serious or fatal injury may be caused as a result.

Note the strength class specification for screws, nuts and bolts. Refer to the table for the corresponding tightening torque. Securely tighten screws, nuts and bolts to the specified values, provided that no other value is specified. The torque specifications refer to a dry coefficient of friction (0.12).

	8.8	10.9	12.9
M 6	9.9 Nm (7.3 ft.lbs)	14 Nm (10.3 ft.lbs)	17 Nm (12.5 ft.lbs)
M 8	24 Nm (17.7 ft.lbs)	34 Nm (25 ft.lbs)	41 Nm (30.3 ft.lbs)
M 10	48 Nm (35.4 ft.lbs)	68 Nm (50.2 ft.lbs)	81 Nm (59.8 ft.lbs)
M 12	85 Nm (62.7 ft.lbs)	120 Nm (88.6 ft.lbs)	145 Nm (104 ft.lbs)
M 14	135 Nm (99.6 ft.lbs)	190 Nm (140 ft.lbs)	230 Nm (166 ft.lbs)
M 16	210 Nm (155 ft.lbs)	290 Nm (214 ft.lbs)	350 Nm (258 ft.lbs)
M 20	410 Nm (302 ft.lbs)	580 Nm (428 ft.lbs)	690 Nm (509 ft.lbs)



Tighten safety bolts and nuts to a 10% higher value.

Maintenance

Special tightening torques

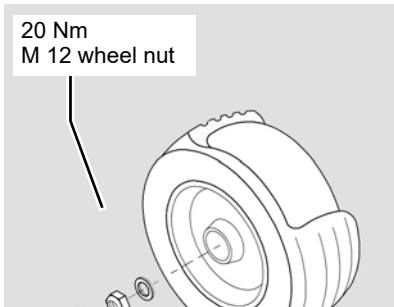
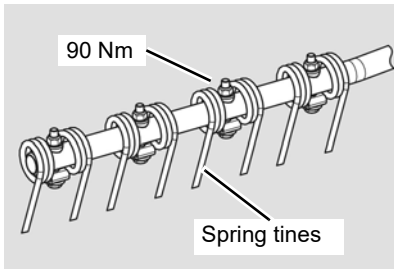

Observe the special tightening torques for the following screwed connections:

- Spring tines: 90 Nm (67 ft.lbs).
- Wheel nuts on the rotor chassis: 20 Nm (15 ft.lbs).

Lubrication points for grease lubrication

Working with the brush

The points marked with a brush symbol should be regularly checked to ensure they move freely and lightly greased with the brush as required. Re-grease each time after cleaning.

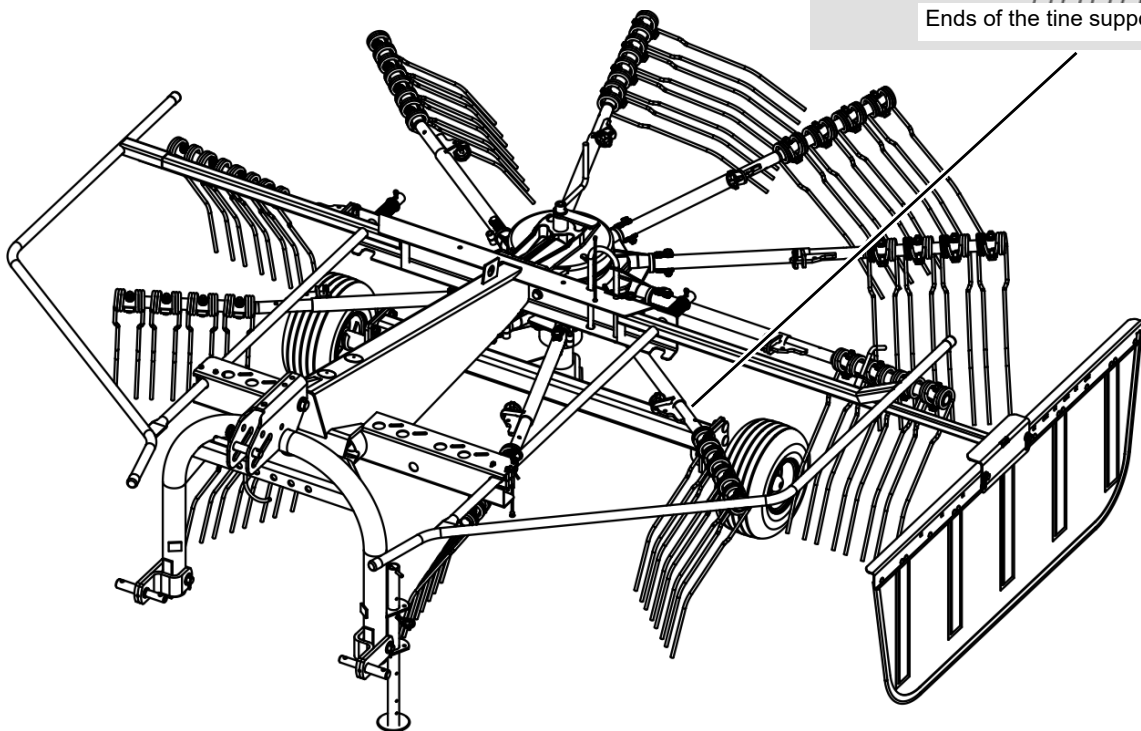
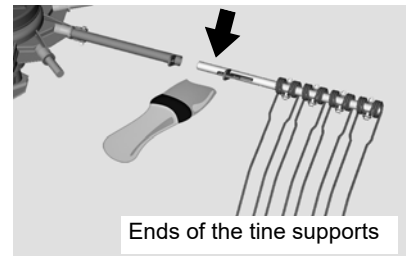

Working with a grease gun

Working with a grease gun

Before applying the grease gun:

- Clean grease fittings on the machine and gun fittings on the grease gun.

Lubricate the bearings with one or two presses of the grease gun. If you feel resistance at the second press, do not press a second time. Too much grease will force the bearings apart. This could allow dust and dirt to enter the bearing, resulting in premature wear.



Hidden lubrication points are marked with an information label. If any labels are illegible or have been lost, it is possible to order new labels as replacement parts and affix them to the implement.

Lubricate the places listed in the illustration as follows:

- After 50 hours of operation.
- Before and after the season.
- Each time after cleaning with a high-pressure cleaner.

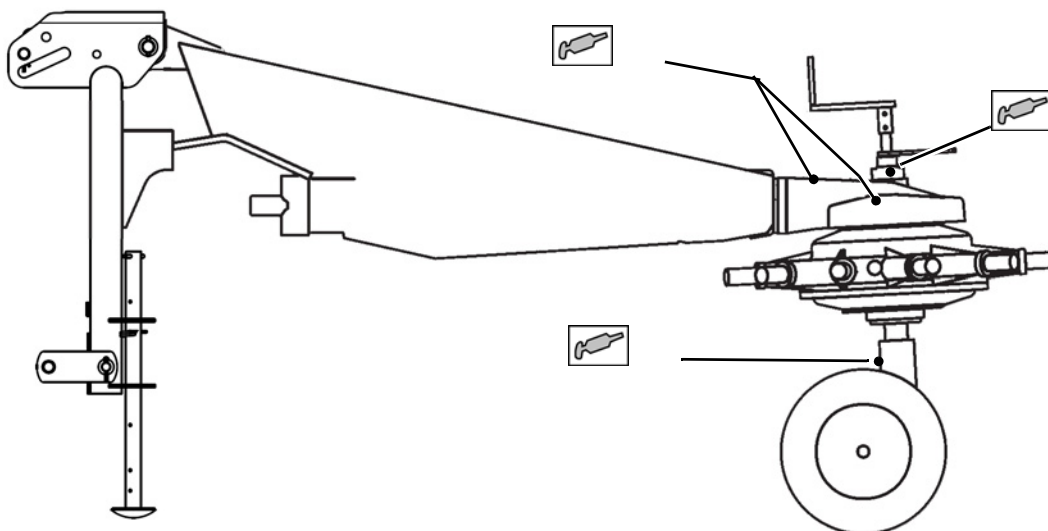

Lubricating the PTO shafts

The PTO shaft manufacturer's own operator's manual is included with each PTO shaft. This includes detailed information on the relevant version of the PTO shaft.



Check the guard components

Check all guard components of the PTO shafts for wear or damage (visual inspection). Replace any defective guard components. An unguarded PTO shaft or damaged guard components can cause very serious injuries during operation.

Lubricate the single joints and their couplings as follows:

- After 50 hours of operation.
- Before and after the season.
- Each time after cleaning with a high-pressure cleaner.

Grease the profile section tubes:

- After 50 hours of operation.
- Before and after the season.
- each time after cleaning with a high-pressure cleaner

Lubricate the guard as follows:

- after 250 hours of operation.
- Before and after the season.
- Each time after cleaning with a high-pressure cleaner.

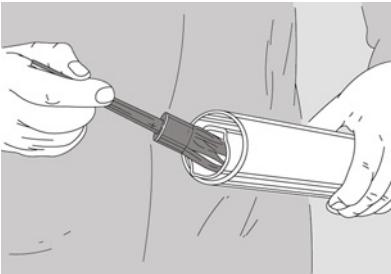

PTO shaft greasing schedule

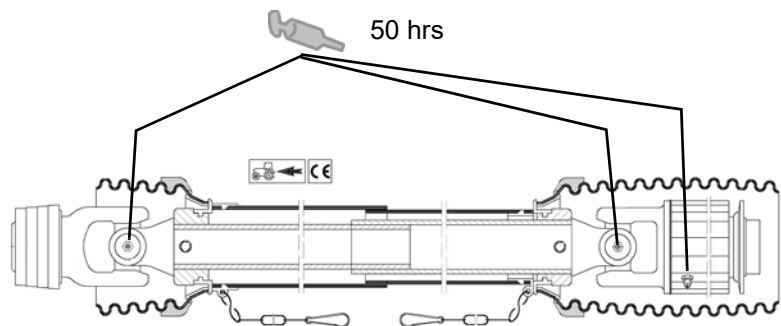

Filling quantities



Observe the correct fill quantities

Observe the correct lubricant fill quantities. Check them regularly. A lubricant level which is too low or too high may result in damage to the machine.

The rotor gear is equipped with a continuous oil lubrication system. Check the lubricants if there is visible loss of lubricant when the machine is in a horizontal position – at least once per season. If there is a visible loss of lubricant, consult your dealer. Otherwise, damage to the machine may be caused as a result.

Gearbox	Max. fill quantity [litres]
Rotor gear, model VF6589	3.4 (3.60 US qt)



No oil change is required.

Checking the rotor gear

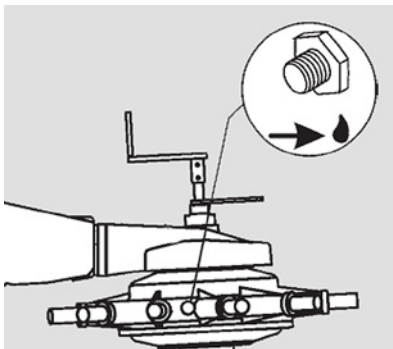

- ▶ Move the machine into a horizontal position.
- ▶ Secure the machine.
- ▶ Unscrew the check screw.
 - The lubricant should reach as far as the bottom edge of the threaded hole.
- ▶ If there is too little oil in the gear box, adjust the oil level using an oil syringe.
- ▶ Screw the check screw back in.
- ▶ Wipe away any remaining oil immediately.

Tyres



Do not drive with worn or damaged tyres

Replace worn or damaged tyres immediately. There is a high risk of accident when driving on the road with such tyres.

Tyre pressure

Check the tyre pressures on a regular basis:

- Daily.
- as required (for example before setting the machine).
- Before and after the season.

Tyre size	Tyre pressure [bar]
Model VF6589: 15 x 6.00 6 PR	1.5 bar (22 psi)

Optional additional equipment does not form part of the standard scope of delivery, and, in this manual, is indicated by a plus symbol [+]. Additional equipment is available to order from your dealer.

Tine saver

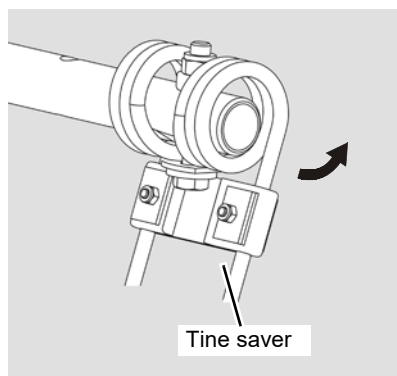

For a good swath deposit, both tine legs must run parallel to one another. This must also be ensured after fitting the tine saver.

Proceed as follows:

- ▶ Fit one tine saver on each tine.
- ▶ Check the direction of rotation of the rotor. The nuts must be attached against the rotor direction.
- ▶ Check the tine position. The tine legs must be parallel.
- ▶ If necessary, loosen the screwed connection until both tine legs run parallel.

Support wheel

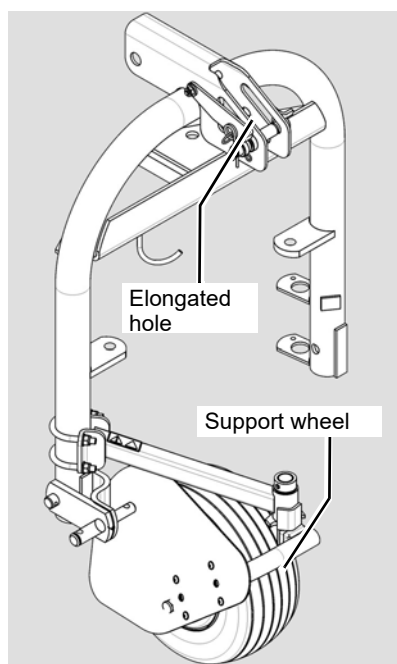

The optional support wheel on the three-point linkage provides better contour guidance.

- ▶ Please note: With the optional support wheel, insert the hitch pin for the top link into the elongated hole and secure it using a safety splint.
 - See »Coupling the top link«, page 33.
- ▶ Check the transport locking device for the support wheel.
 - See »Locking the transport locking device for the support wheel [+]«, page 48.
 - See »Unlocking the transport locking device for the support wheel [+]«, page 52.



In the work position, the top link pin must be fitted centrally in the elongated hole, so that the machine is able to adapt to the unevenness of the ground.

Accessories

Tandem axles

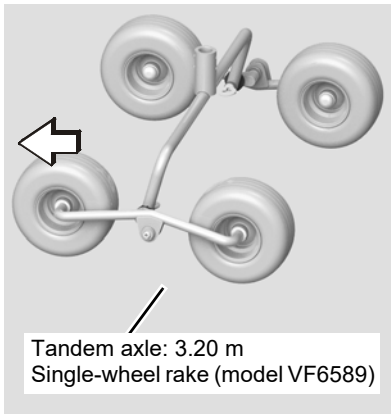

The optional tandem axles make for smoother running of the machine and improved contour guidance.

The tandem axles replace the running wheels. Separate assembly instructions are supplied.

- ▶ Long stub axle pointing forward in direction of travel.



Ensure that the running direction of the tandem axles is correct. Otherwise, damage to the machine may be caused as a result.

Warning sign kit

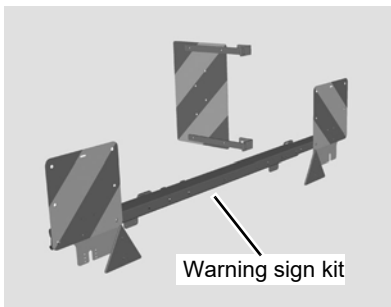

The optional warning sign kit increases safety when travelling on the road.

Lighting equipment set

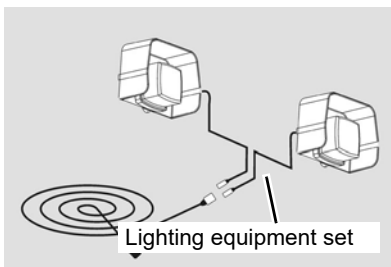

The optional lighting equipment set increases safety when travelling on the road.

Slope locking mechanism

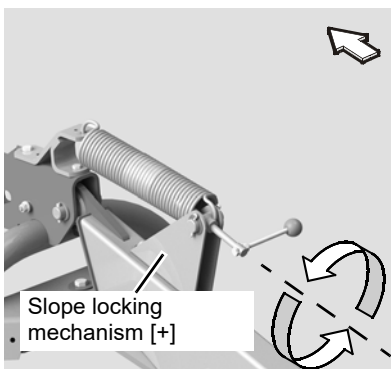

The optional slope locking mechanism improves ground contact when travelling on hills and ensures that the rotor gathers the crop reliably, even on hillside locations.

→ Setting: See »Slope locking mechanism [+]*«*, page 42.

Troubleshooting

Faults can often be eliminated quickly and easily. Before contacting Customer Service, refer to the table to check whether you can remedy the fault yourself.



In case of a fault, proceed as follows:

- ▶ Immediately stop operation.
- Switch off the PTO shaft drive.
- Switch all operating controls to the neutral or park position.
- Put the tractor's parking brake into the park position.
- Switch off the tractor engine, put the parking brake in the park position, remove the ignition key and secure the tractor against rolling away.
- Ensure the machine is standing on firm, secure and level ground, and provide additional support, if necessary.
- Secure the machine against rolling away.

The fault must be repaired before work can be resumed. Damage to the machine and serious or fatal injury may be caused as a result.

Problem	Cause	Solution
Rotor is leaving crop behind on one side and is digging too deeply into the ground on the other side.	Incorrect adjustment of rotor pitch.	→ Chapter »Preparing for use«, section »Rotor pitch«, page 39
Rotor is leaving crop behind across the entire width.	Working depth set too high.	→ Chapter »Preparing for use«, section »Rotor pitch«, page 39
Crop is heavily contaminated.	Rotor tines set too low.	→ Chapter »Preparing for use«, section »Rotor pitch«, page 39
		→ Chapter »Coupling the machine«, section »Coupling the three-point linkage«, page 32
Machine not operating cleanly at high speed	Rotor tines set too high. Uneven terrain.	→ Chapter »Preparing for use«, section »Rotor pitch«, page 39
	Speed too high to process crop mass	Reduce speed.
Rotor dragging crop along – Unclean swath form	Crop mass too large.	Reduce speed.
	Rotary speed too high.	Reduce speed.
PTO shaft coupling responding frequently	Crop mass too large or uneven.	Reduce speed.
	Rotor tines set too low.	→ Chapter »Preparing for use«, section »Rotor pitch«, page 39
Noise production during work	Loose screwed connections or worn-out tine supports.	Check tine supports and screwed connections on tines.
	Tine support bent	

Circuit diagrams

Lighting circuit diagram

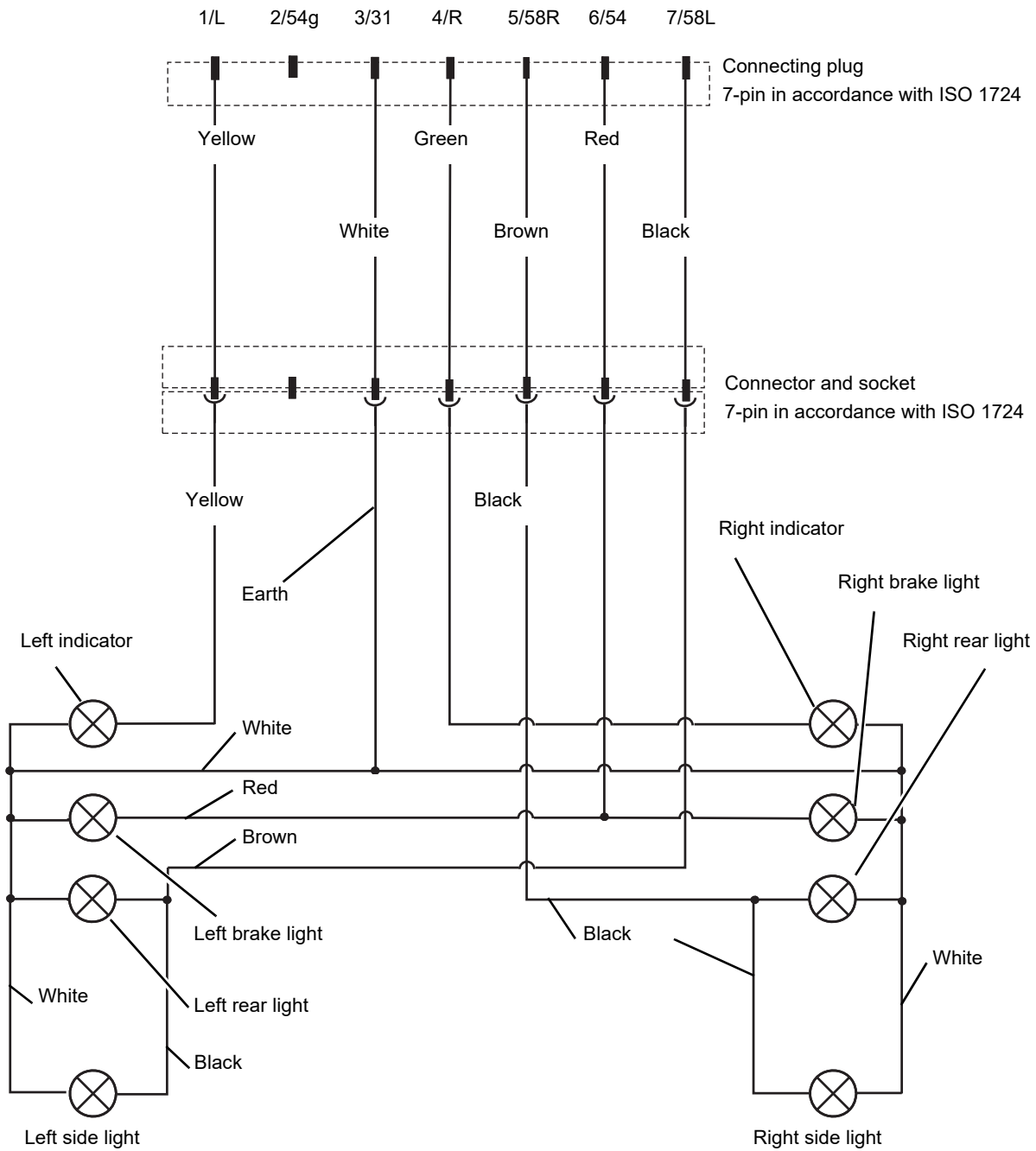

Disposal

During decommissioning, the individual parts must be disposed of properly and in an environmentally friendly manner. Please observe the waste disposal guidelines that are currently in force.

Plastic parts

Plastic parts can be disposed of in normal household waste (residual waste), depending on the laws specific to your country.

Metal parts

All metal parts can be sent for recycling.

Oil

In terms of waste legislation, environmentally-compatible hydraulic oils must be stored, collected and disposed of separately in accordance with regulations.

Rubber

Rubber parts, such as hoses or tyres, must be brought to a rubber recycling centre.

Original EC Conformity Declaration

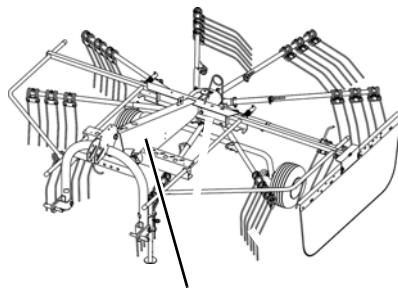

Type plate and CE marking

We

**Kverneland Group Kerteminde AS
Taarupstrandvej 25
DK-5300 Kerteminde
Denmark**

declare with sole responsibility that the product

**Vicon Index 323
Kubota RA1032
Kverneland 9032
in all equipment variants and its
accessories**

Model: VF6589

**Valid from machine number:
VF65892901-**

complies with the following relevant EU provisions:

- Directive 2006/42/EC
- Directive 2014/30/EU

The following harmonised standards have been applied:

- EN ISO 4254-1:2015
- EN ISO 4254-10:2009 + AC:2010

Kverneland Group Kerteminde AS
Kerteminde, 02.01.2021

Claus Udengaard Thomsen

CEO
and authorised representative*

* person who is responsible for compiling the technical documentation and resides in the European Community. See address above.

A			
Adjusting			
Chassis	39	Uncoupling	63
Rotor pitch	39	Maintenance	65
Working depth	41	Lubrication points	71
		Screwed connections	69
		Maintenance intervals	68
C			
Care	62	O	
Check list		Oil	
Road transport	49	Protective measures	66
Checking the scope of delivery	28	Operation	56
Circuit diagram			
Hydraulics	78	P	
Lighting equipment	78	Preparation for road transport	
Cleaning	62	Transport position	44
Conformity Declaration	80	Preparations on the field	50
Connecting the electrics	36	Work position	50
Coupling		Proper use	22
PTO shaft	35	PTO shaft	
Coupling the three-point linkage	32	Attaching	35
		Lubrication	73
D			
Designation of components	23	R	
Disposal		Road transport	43
Metal parts	79		
Plastic parts	79	S	
		Safety	7
E		Care and maintenance	18
EC Conformity Declaration	80	Pictorial symbols	9
Explanation		Uncoupling	17
Maintenance terms	67	Single-wheel rake	22
		Speed	48
F		Swath former	
Fitting the tine supports	53	Adjusting the direction of travel	55
		Adjusting the height	55
I		T	
Inserting the parking stand	34	Target group	4
		Technical specifications	
L		Dimensions in work position	25
Lubrication points	71	Machine equipment	27
Machine	71	Tractor equipment	26
PTO shafts	73	Tractors with quick-release couplings	32
		Tractors without quick-release coupling	33
M		Tyres	74
Machine		Tyre pressure	74
Putting away after the season	64		
Setting down	63		