

Technical Service Manual

Power Harrow M-series H-series S-series 3m 3.5m 4m

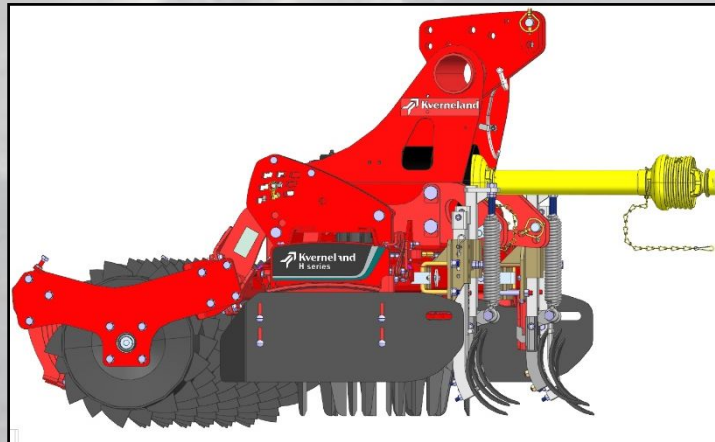

Date: 01.02.2021

Machine type: Power Harrow M-series H-series S-series 3m - 3.5m - 4m

Address: Kverneland Group Soest GmbH.
Coesterweg 42
59494 Soest
Germany

Receiver: Technical Service

Details: Technical machine information, adjustments and failure finding

Serial number: \geq serial number ACPOHxx3339 (04.01.2021)

Content

General data and equipment.....3

- Road transport
- Working position
- Construction
- Optional equipment glossary
- Rollers options
- Lighting Equipment
- Leveling bar

Getting started.....23

- Connecting power harrow to tractor

Maintenance and Troubleshooting.....26

- Adjusting side deflectors
- Replacing tines
- Changing gearbox speed
- Changing tine carrier
- Checking gearbox oil level

Attachment.....39

- Oil and grease characteristics
- Bolt tightening torque tables
- Resetting operation of tine carriers' "TIMING",
- Test stand

M Series – General data and equipment

Technical Data	M series		
Working width (m)	2.5		3.0
Transport width (m)	2.5		3.0
PTO - Input speed (rpm)	PTO shaft with auto clutch 1-3/8" Z6 (Walterscheid) 540/1000 rpm		
Rotor Speed (rpm)	311 (optional: 358 with 540 rpm / 351 with 1000 rpm)		
Min / Max Power requirement (KW)	60 - 105		
Maximum allowed Power (hp PS)	140		
Gearbox overload protection	2000 Nm (540U/min) 1800Nm (1000U/min)		
Number of rotors	10		12
Number of tines	20		24
Tine dimension (mm)	12 x 280		
Tines fitment	Standard Bolted / Quick-Fit as option		
Weight with Packer Roller 500mm (kg)	1350		1550
Working depth adjustment	Mechanical by bolts		
Three point linkage	Cat. II & III & IIIN		

H Series – General data and equipment

Technical Data	H series		
Working width (m)	3.0	3.5	4.0
Transport width (m)	3.0	3.5	4.0
PTO - Input speed (rpm)	PTO shaft with auto clutch 1-3/8" Z6 (Walterscheid) 1000 rpm		
Rotor Speed (rpm)	336 (362,450 optional)		
Min / Max Power requirement (KW)	60 - 130		
Maximum allowed Power (hp PS)	180		
Gearbox overload protection	2000 Nm per lateral drive automatic clutch		
Number of rotors	12	14	16
Number of tines	24	28	32
Tine dimension (mm)	15 x 315		
Tines fitment	Quick-Fit as standard		
Weight with Packer Roller 500mm (kg)	1610	1850	2100
Working depth adjustment	Mechanical by bolts		
Three point linkage	Cat. II & III & IIIN		

S Series – General data and equipment

Technical Data	S series			
Working width (m)	3.00	3.50	4.00	4.50
Transport width (m)	3.00	3.50	4.00	4.50
PTO - Input speed (rpm)	PTO shaft with auto clutch 1-3/8" Z6 (Walterscheid) 1000 rpm			
Rotor Speed (rpm)	298 (365,435 optional)			
Min / Max Power requirement (KW)	60-180			
Maximum allowed Power (hp PS)	250			
Gearbox overload protection	2500 Nm per lateral drive automatic clutch			
Number of rotors	12	14	16	18
Number of tines	24	28	32	36
Tine dimension (mm)	18 x 330			
Tines fitment	Quick-Fit as standard			
Weight with Packer Roller 500mm (kg)	1900	2080	2290	2560
Working depth adjustment	Mechanical by bolts			
Three point linkage	Cat. II & III & IIIN			

General data and equipment

M series / H series / S series

Road transport



Transport Height:
H = 500 mm minimum

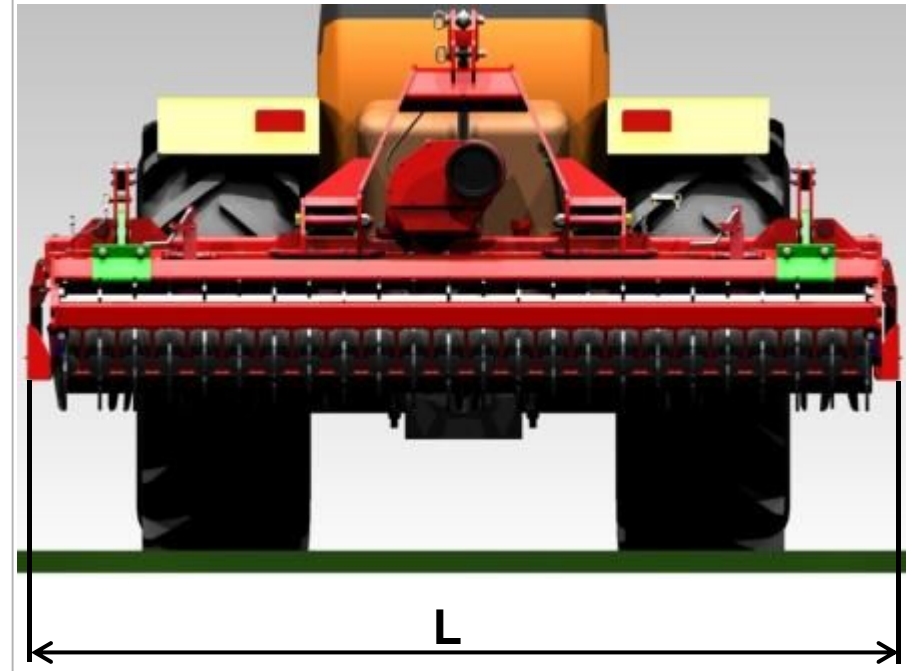

M- / H- / S-series				
Working Width	3.00 m	3.50 m	4.00 m	4.50 m
Transport Width	3.00 m	3.50 m	4.00 m	4.50 m

General data and equipment

M series / H series / S series

Working position



Working position: Higher position

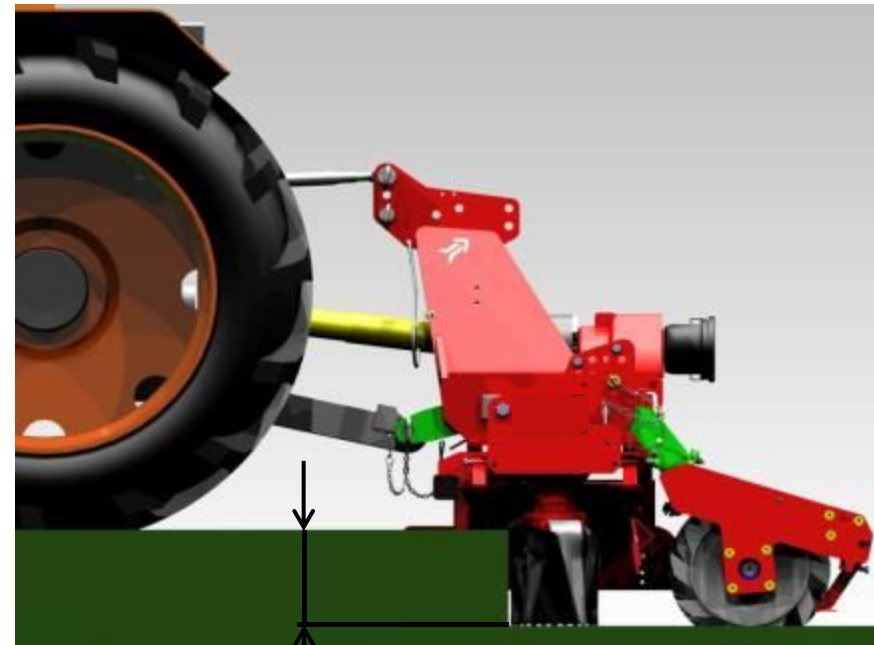

Maximum cutting depth

Working position: Lower position

Maximum cutting depth: M-series: 280 mm

H-series: 315mm S-series: 330mm

General data and equipment

M series / H series / S series

Construction

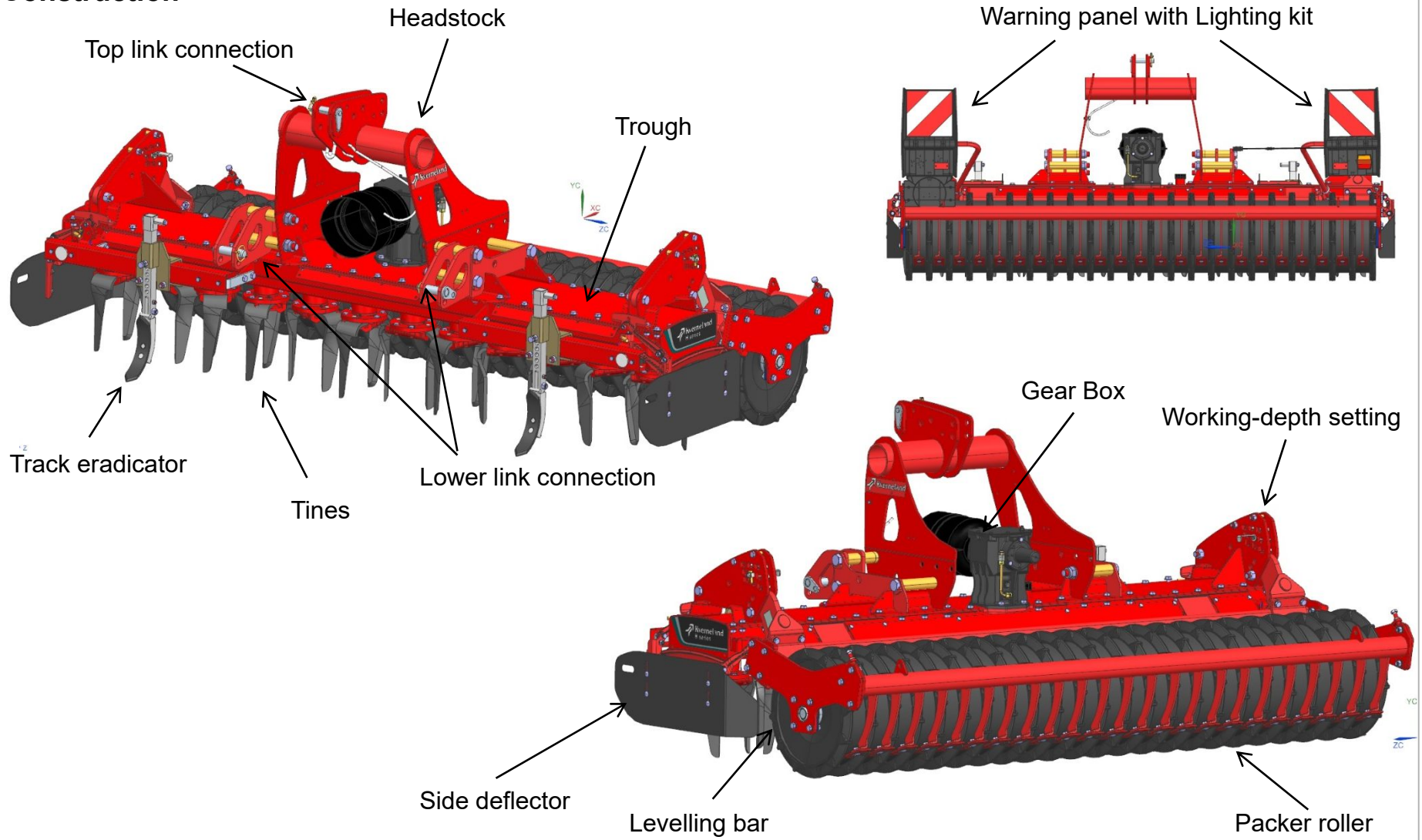

General data and equipment

M series / H series / S series

Construction

Headstock

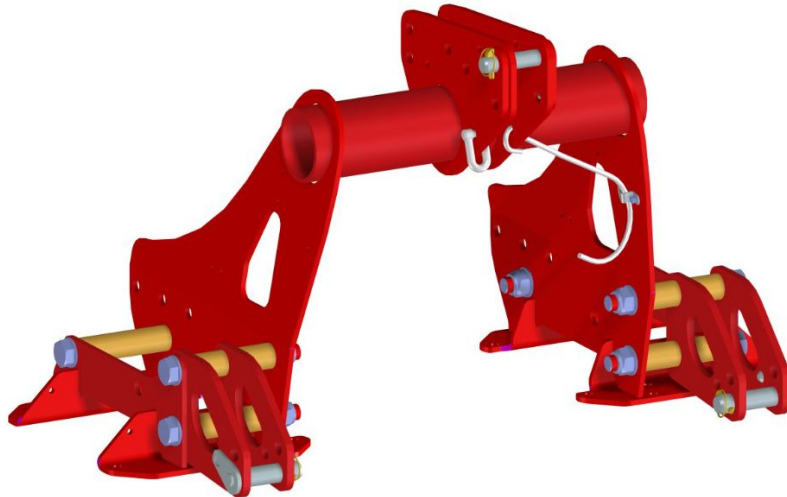

- Tough headstock
- Overload tested in Klepp laboratory
- Standard connection for hydrolift and Kverneland triangle
- Cat. 2 / Cat. 3N / Cat.3
lower link connections

Production start: middle of 2019

Construction

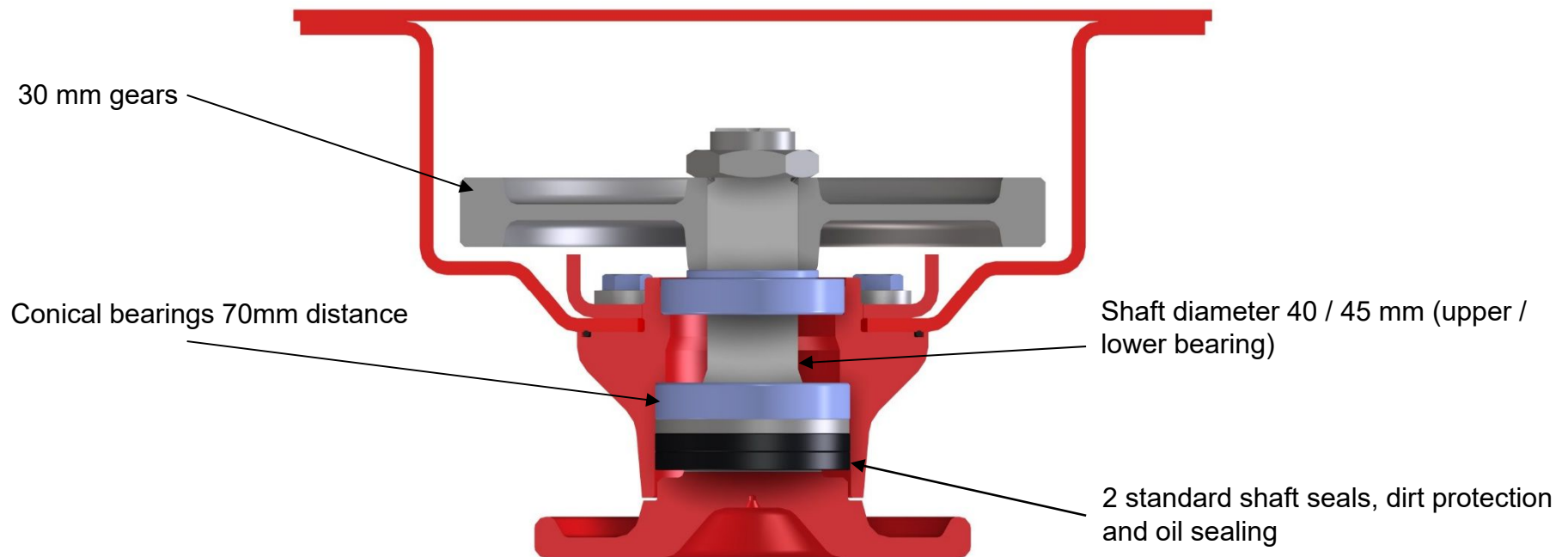

General data and equipment

M series - Trough

Construction



- Two conical bearings with a large distance and rotor clearance
- Trough dimension
140 x 400 mm (6 mm sheet metal)
- Bolted Tines Standard (Quick-Fit as option)
Tine dimension 12 x 280 mm
- Bearing distance 70mm

Construction

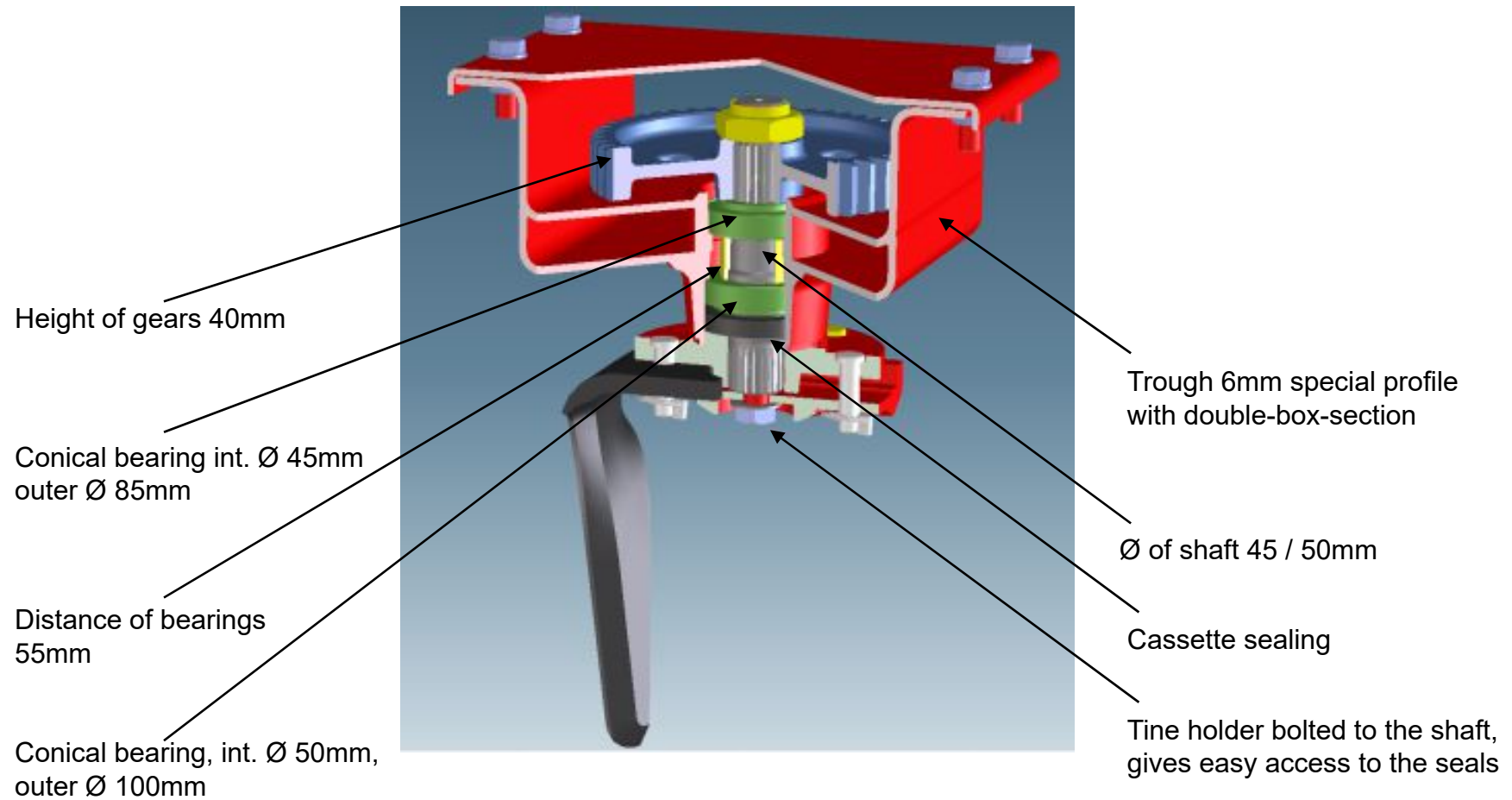

Construction



- Self supporting structure with double-box-section
- Conical bearing system
- High rigidity even when loaded
- Quick-Fit Tines as Standard
Tine dimension 15 x 315 mm
- Simple clear design
- Easy and low maintenance

Construction



New gearbox “Rögelberg”
with “Bevel” transmission system

- More space for the PTO shaft
- Efficient power train
- Less weight

**Production start: 0-series 2020,
Limited series spring 2021
Full production autumn 2021**

Construction

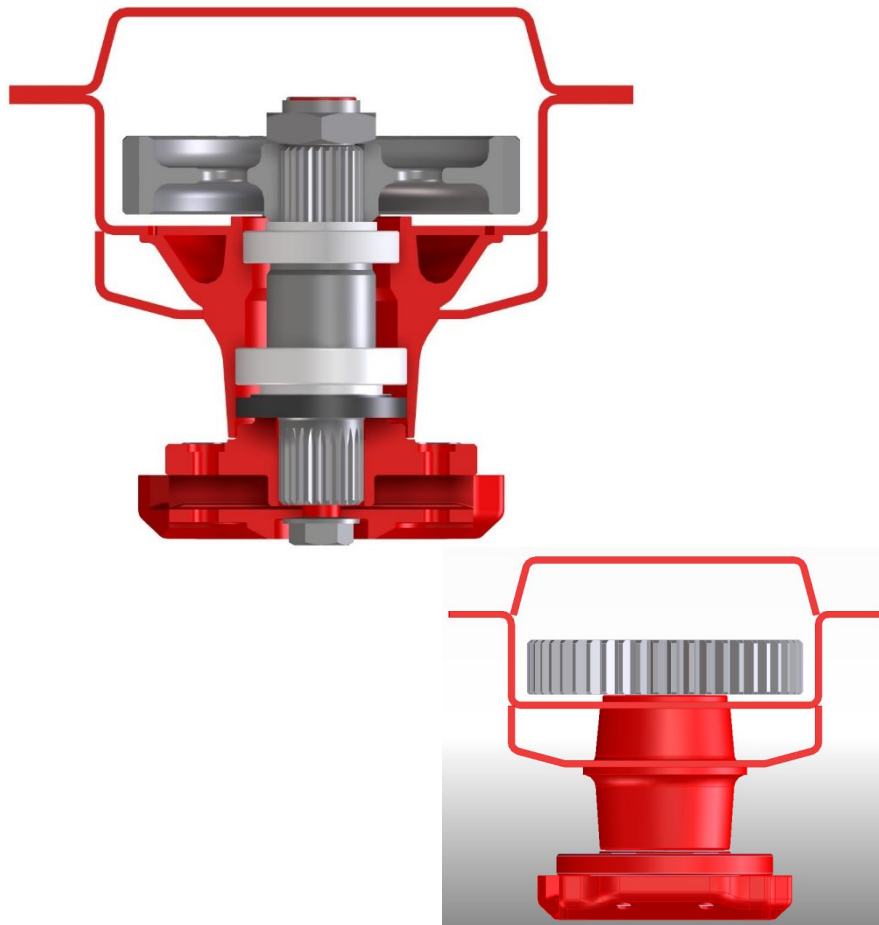

- Trough as SANDWICH DESIGN profile
- Reinforcement plate
- Trough dimension: 200x400mm
- Ø 50mm/60mm shaft
- Bearing distance: 84.5mm
- Bearings 110-120mm
- Rotor clearance: 90.5mm
- Hardened gears
- Large clearance 125mm between trough and tine holder

Construction

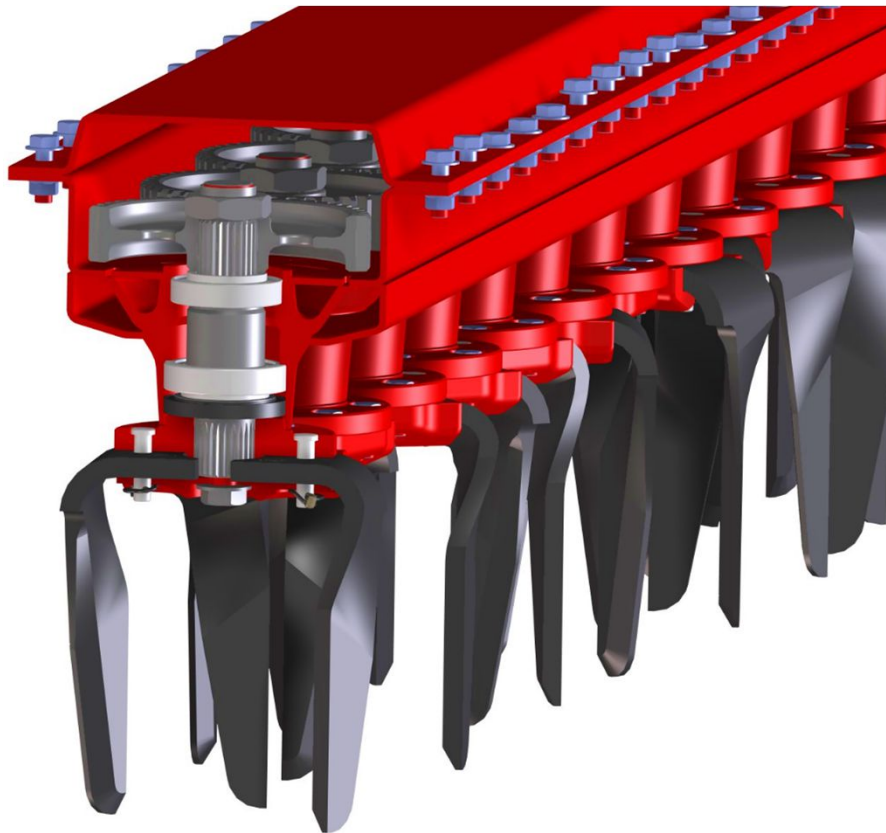

- Self supporting structure
- Conical bearing system
- High rigidity even when loaded
- Quick-Fit Tines as standard
Tine dimension 18 x 330 mm
- Simple clear design
- Easy and low maintenance

General data and equipment

Construction



Safety Clip 6x25mm

Pins fixed at top and bottom:

No bending, no stress on the clip

- Tines are fixed by pin and safety-clip (Quick-Fit system as Standard offer for H- and S-series, for M-series as option)
- No tools necessary to change tines

Wide tine holder

- Reduces stress and wear of tine and tine pocket
- Different type of tines; standard shape, positive angle and carbide treated for longer working life

General data and equipment

EURO connection with parallelogram

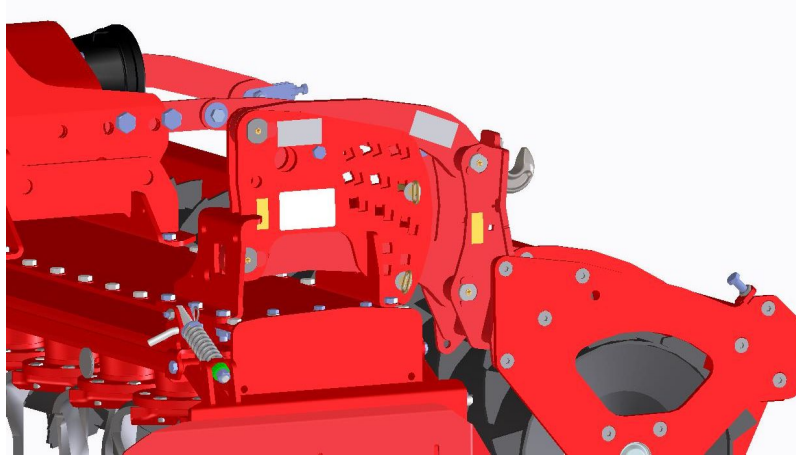

STANDARD connection with single arm

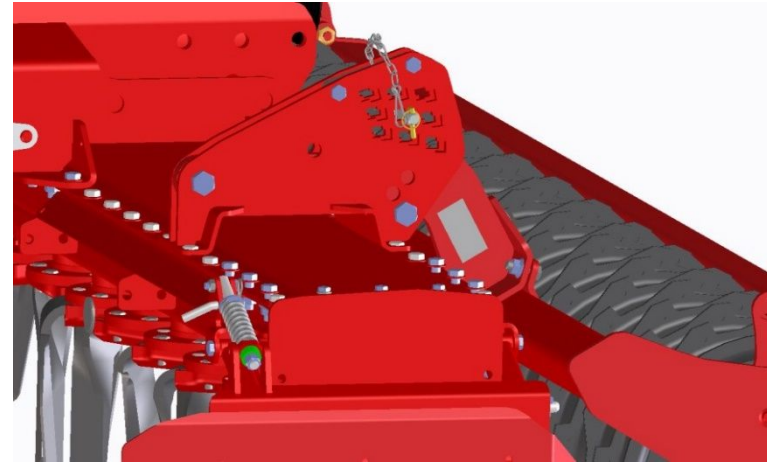

PRO connection (until 06.2019)

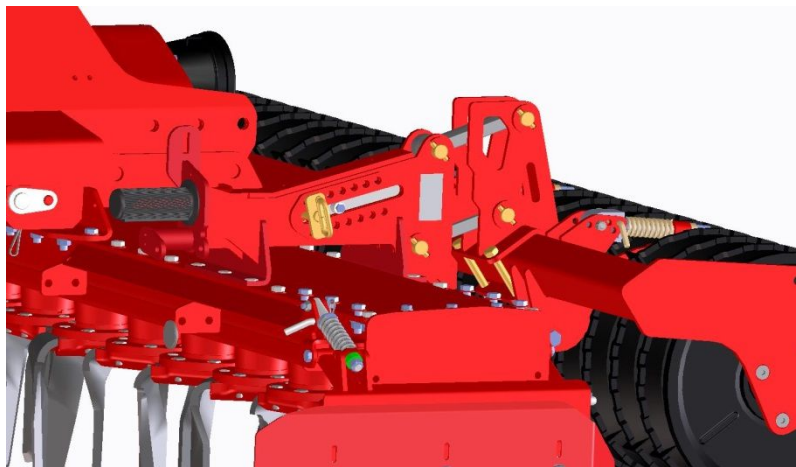

MC connection (until 06.2020)

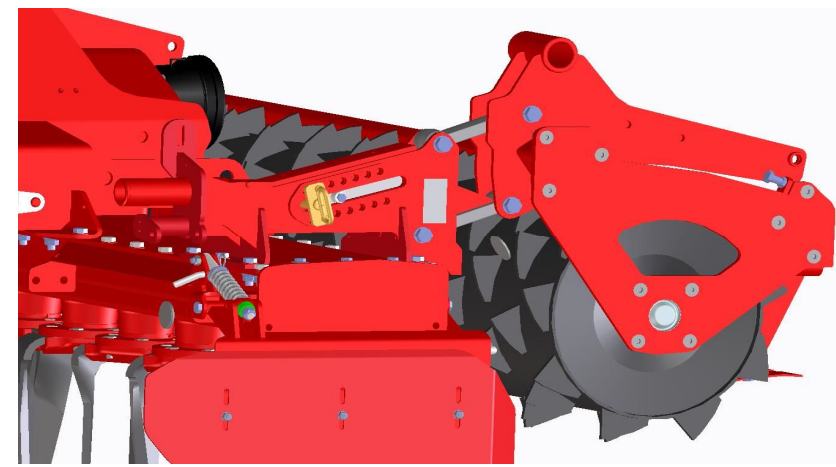

General data and equipment

Tines



Quick fit tool

Quick fit tine



Quick fit tool

Quick fit **positive angle** tine



Quick fit tool

Quick fit tine with **carbide** insert



Quick fit tool

Quick fit **positive angle** tine with **carbide** insert

General data and equipment

Tines

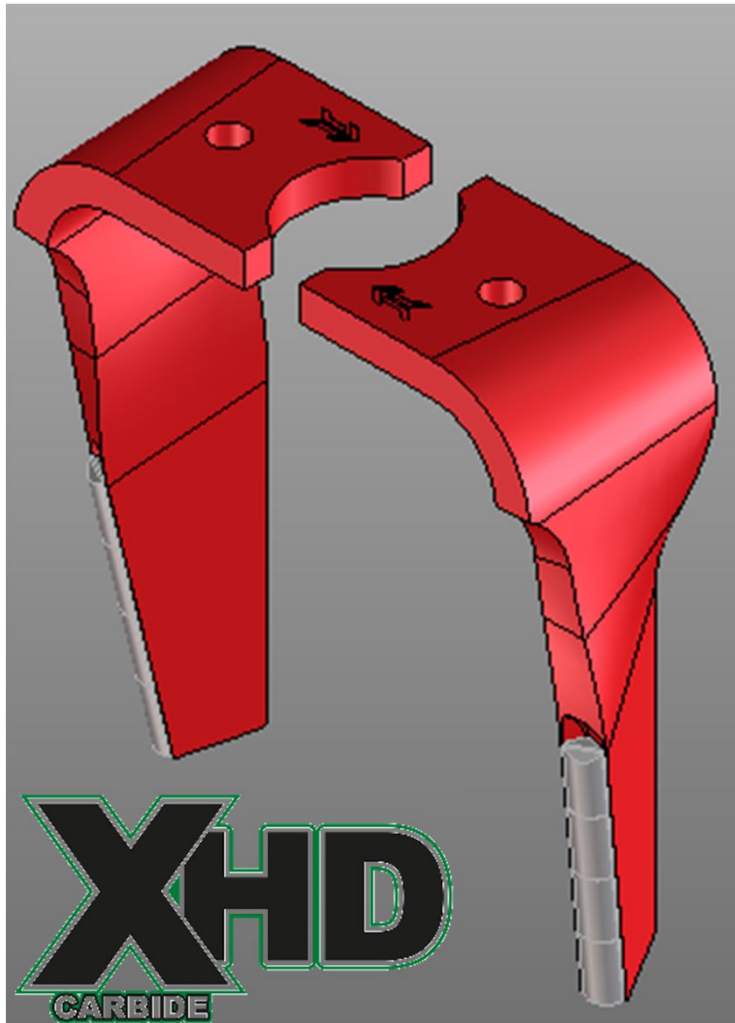

The new **XHD Tines** generation

Available only for:

- H-Series and S-Series
- F30 and F35 model
- Extra long lifetime

Only available via Spare Parts

General data and equipment

Optional equipment

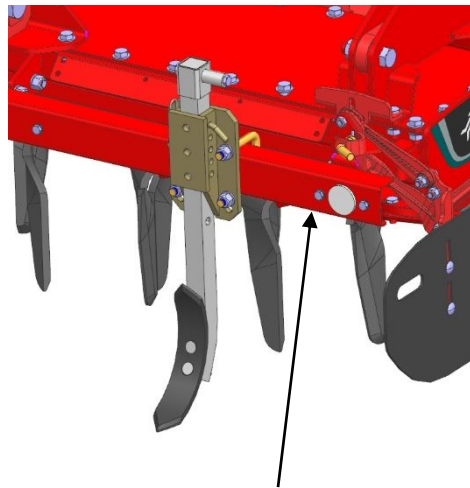

Track eradicator bar

Rigid track eradicator

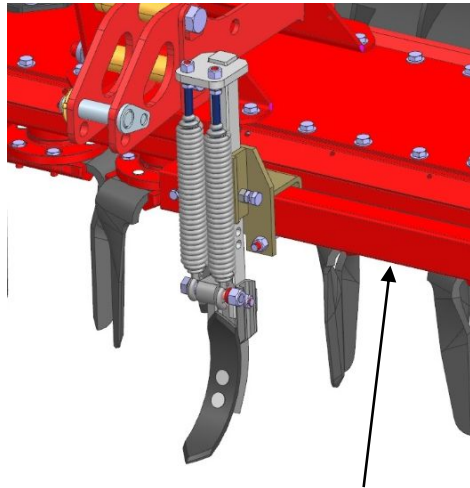

Track eradicator bar

Spring track eradicator

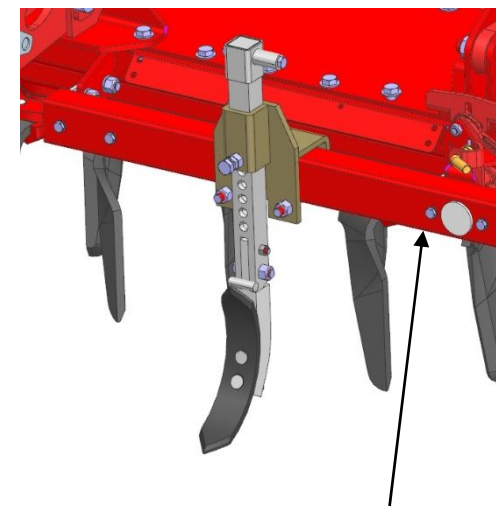

Track eradicator bar

Shear bolt track eradicator

1 or 2 eradicators can be assembled at each side

General data and equipment

Optional equipment

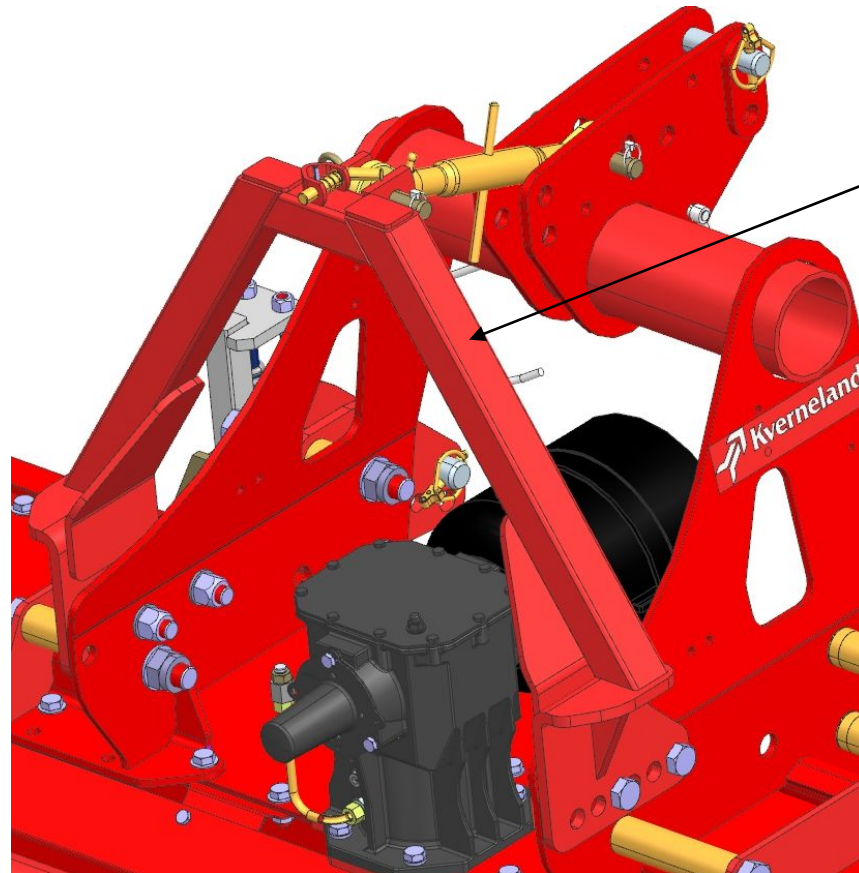

seeder assembly support / mounting triangle
for DA and S-drill



General data and equipment

Optional equipment

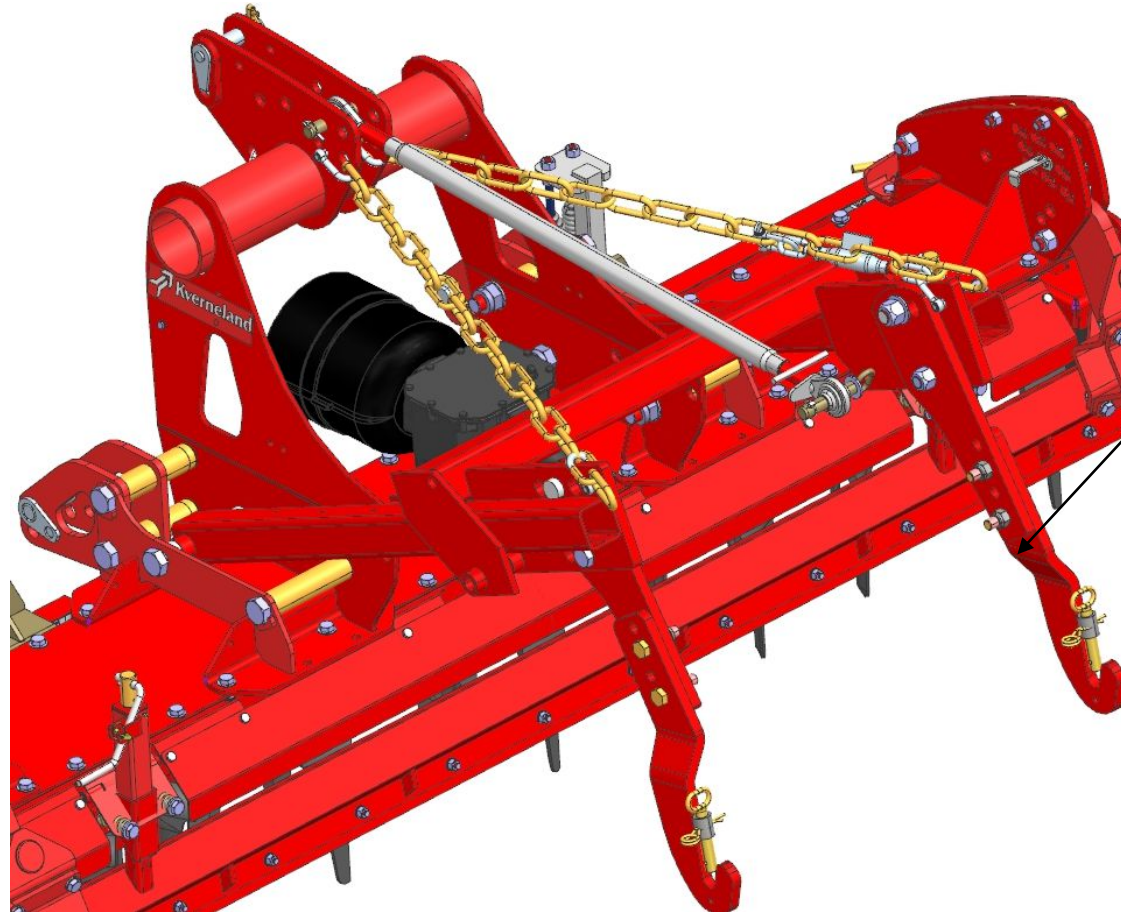

Mechanical seeder assembly hitch

Lifting capacity 1400 kg

General data and equipment

Optional equipment

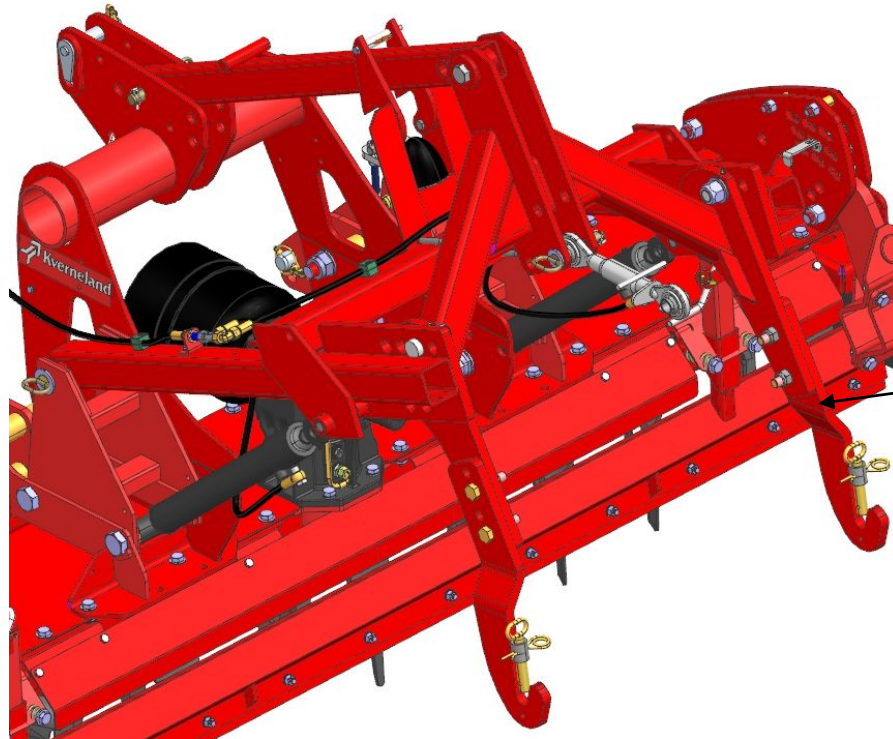

Hydraulic seeder assembly hitch

Lifting capacity 1600 kg

Lifting capacity 2500 kg only for S-series



General data and equipment

Optional equipment

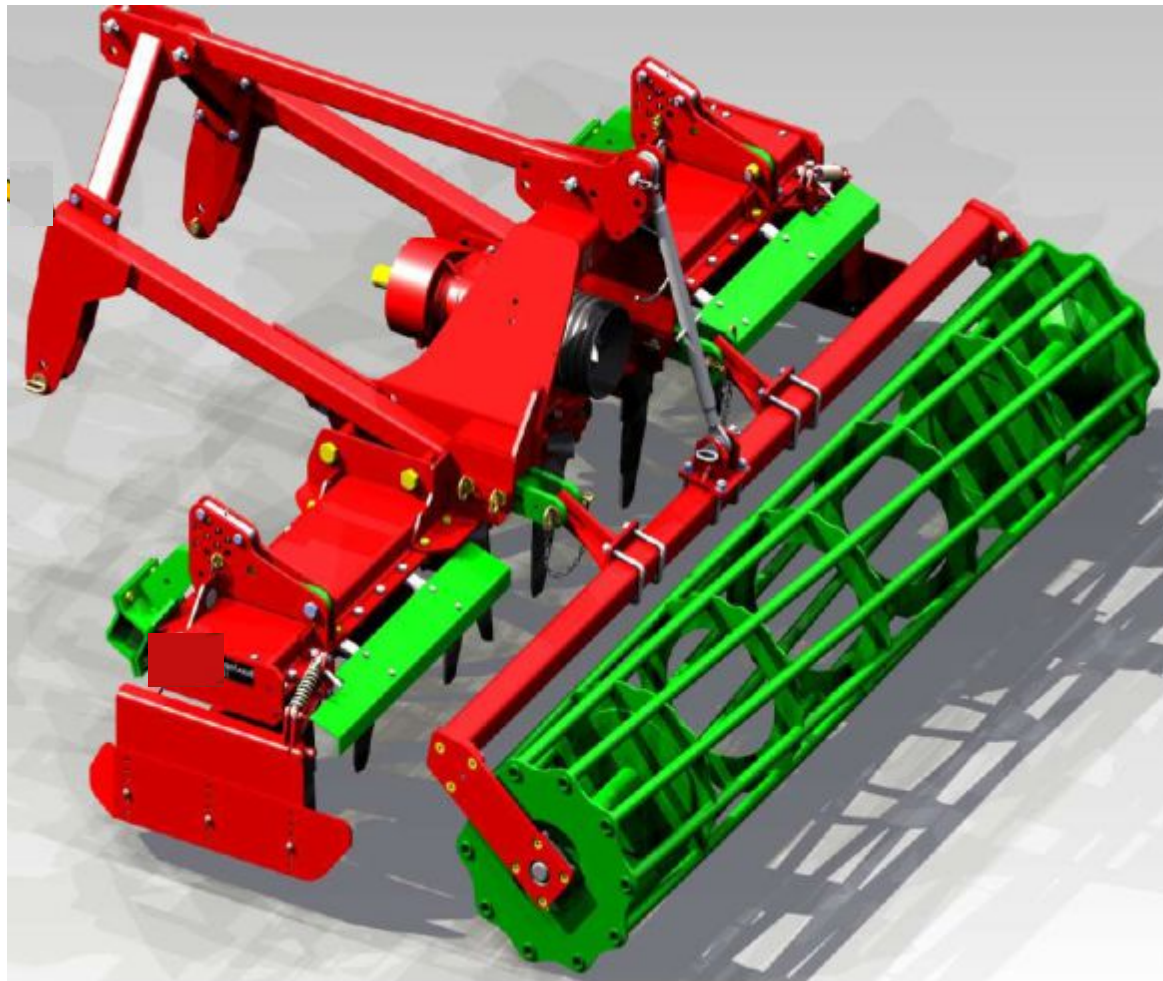

Front Hitch Kit

with cage-roller 2.5 m for adjusting the working-depth

Driveline GKN Autom. clutch 1800 Nm
1-3/8" Z6 L=1110mm

Available for M- and H-series

Tractor with Front PTO necessary

General data and equipment

Lighting Equipment

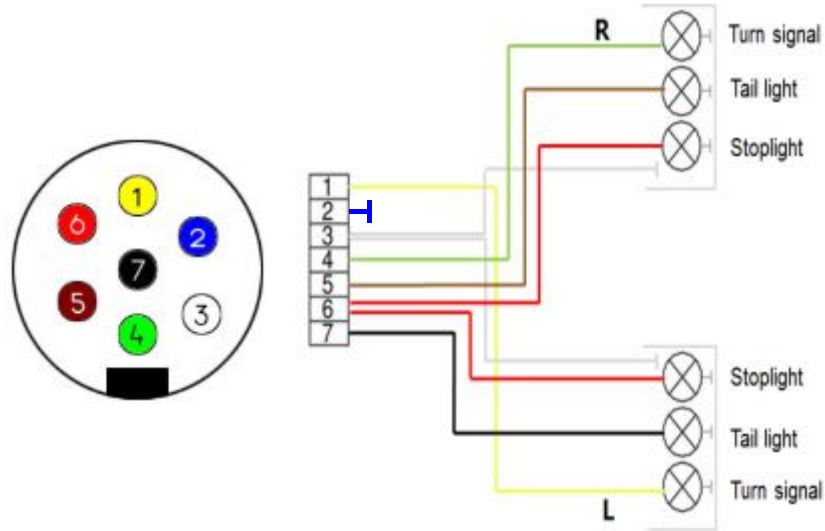

cable layout-7 pin			
Number	Colour	Terminal	Function
1.	yellow	L	turn signal left
2.	---	54g	---
3.	white	31	ground
4.	green	R	turn signal right
5.	brown	58R	tail light right
6.	red	54	stoplight
7.	black	58L	tail light left

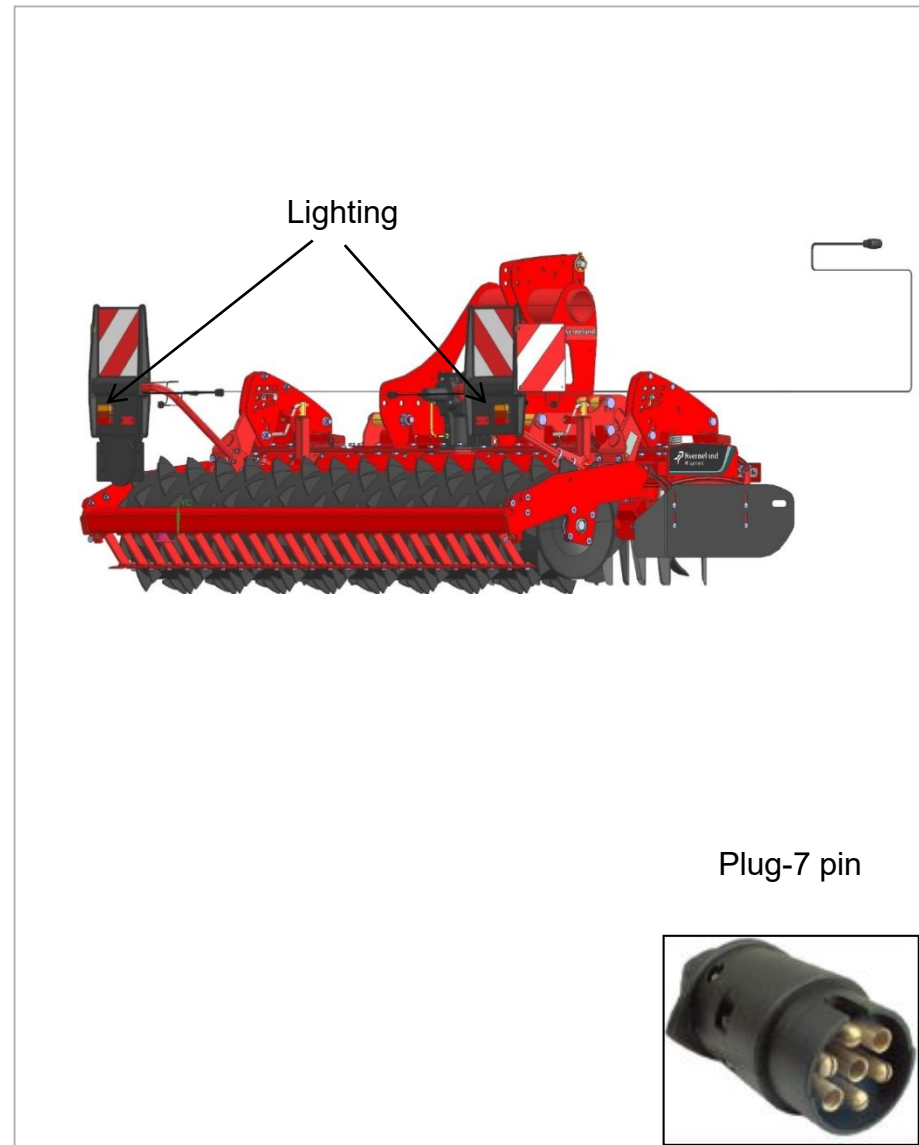

Rollers options

Cage roller \varnothing 550mm



LIGHT TO MEDIUM

Toothpacker roller \varnothing 575mm



LIGHT TO MEDIUM TO HEAVY

New Actiline roller \varnothing 550mm, availability in summer 2021



LIGHT TO MEDIUM TO HEAVY

Actipack roller \varnothing 560mm



MEDIUM TO HEAVY

Cracker roller \varnothing 550mm



MEDIUM TO HEAVY

General data and equipment

Rollers options

550 mm diameter **cage roller**

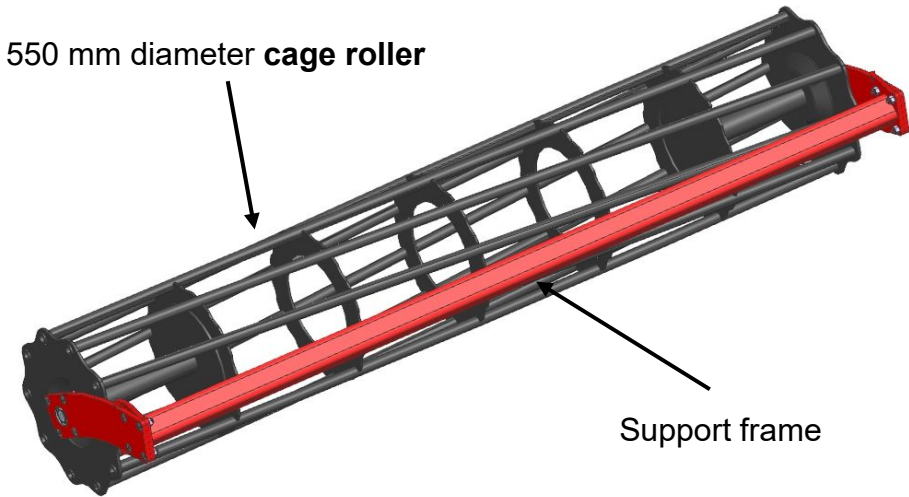

560 mm diameter **actipack roller**

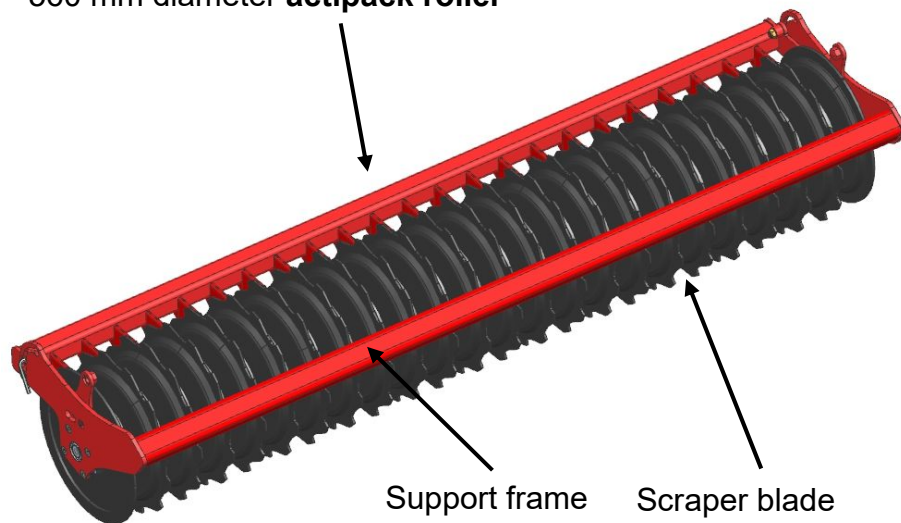

General data and equipment

Rollers options

575 mm Diameter **Toothpacker roller**

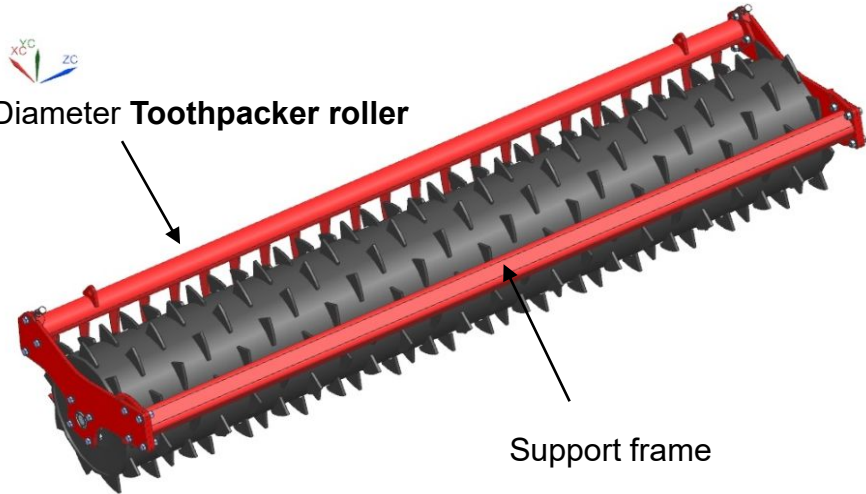

Support frame

550 mm Diameter **Cracker roller**

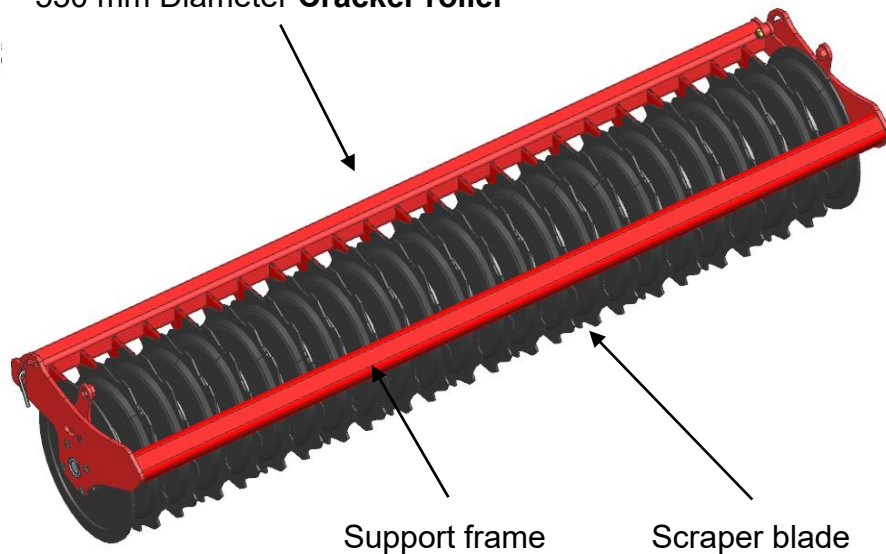

Support frame

Scraper blade

Rollers options

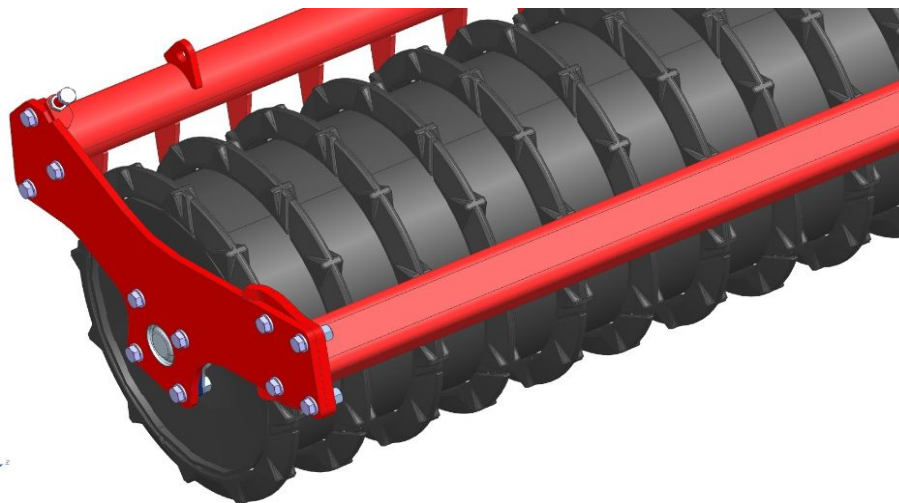
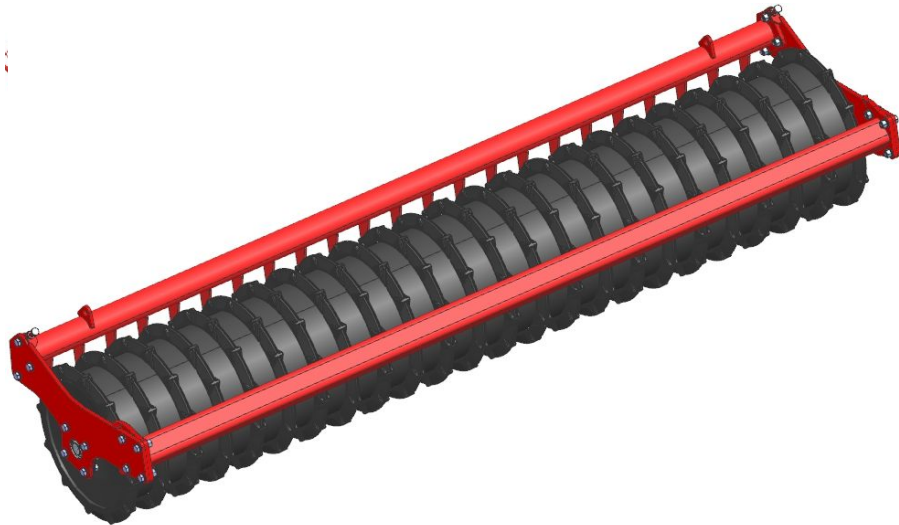

Actiline ø 550mm - 185kg/m

- Trapezoidal roller with relatively narrow crest width of 40mm.
- Stripe-wise consolidation and V shape furrow in front of the CX-II seed coulter bar for a perfect seed placement and even field emergence.
- Supporting water holding capacity and oxygen exchange.
- Optimum performance on light to heavy soil.
- Good carrying capacity with full self-cleaning effect.
- Crests support the constant drive of the roller and avoid slip in light or tough and wet conditions.
- Two different ring distances of 12.5cm and 15cm.
- Carbide-coated scrapers as option.
- Standard or EURO-connection (15cm version excl. with EC-connection).

General data and equipment

Levelling bar position

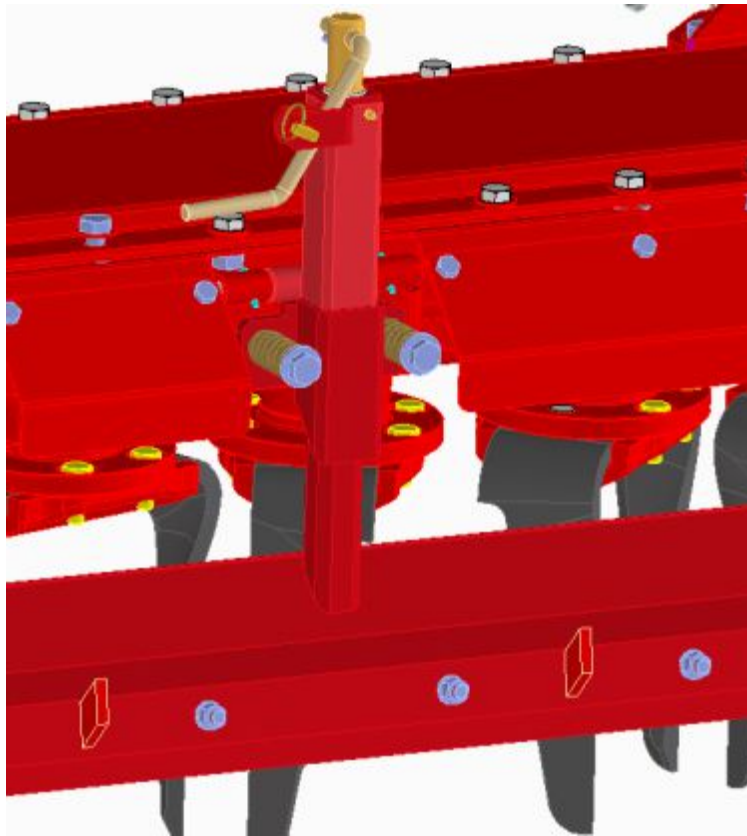

- Infinite adjustable with spindle
- Spring loaded to prevent overload
- Strong bracket with 4 bolts
- Negative angle for a better soil flow
- Scale for better alignment of each side



Getting started

old version headstock

Connecting power harrow to tractor

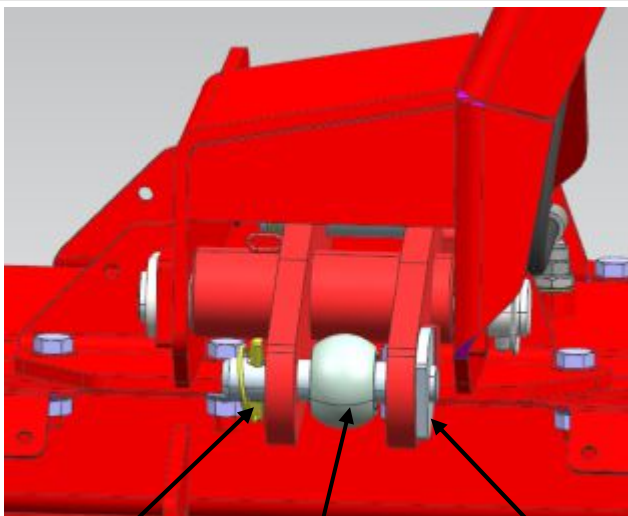
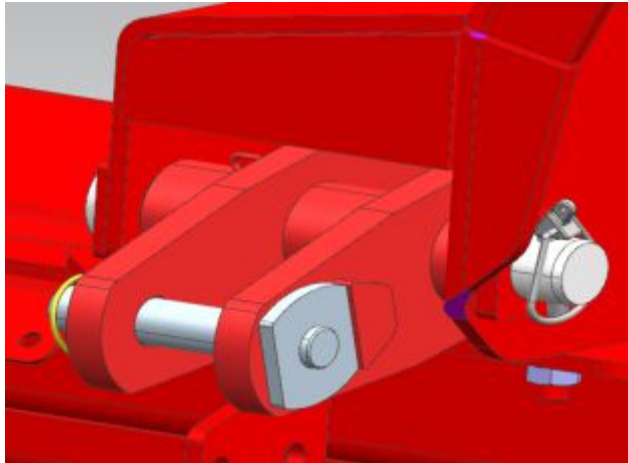

Safety pin Spherical joint Lower pin hitch

H-series category II lower hitch

Step 1

- Disassembly the lower pins hitch, including the safety pins
- Insert the spherical joints , then insert again the lower pins hitch and the safety pins

Getting started

old version headstock

Connecting power harrow to tractor

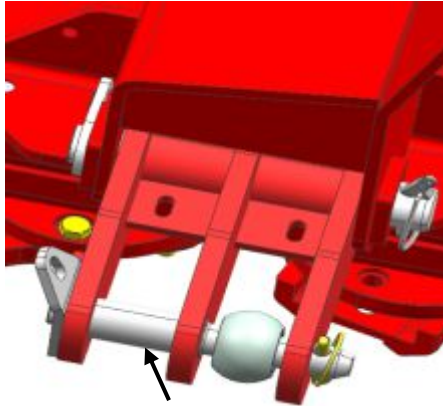

Final lower hitch assembly II category

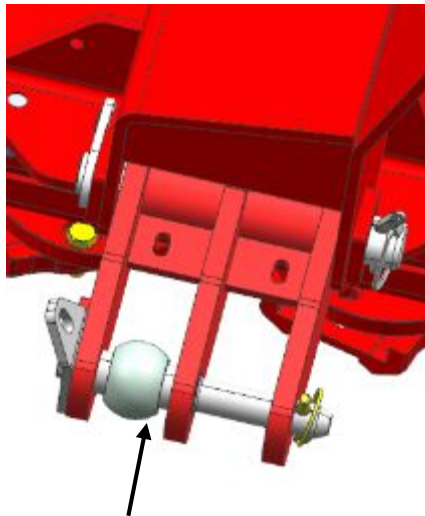

Final lower hitch assembly III category

H-series category II & III lower hitch

Step 1

- Disassembly the lower pins hitch, including the safety pins
- Insert the spherical joints , then insert again the lower pins hitch and the safety pins

New version headstock

Connecting power harrow to tractor

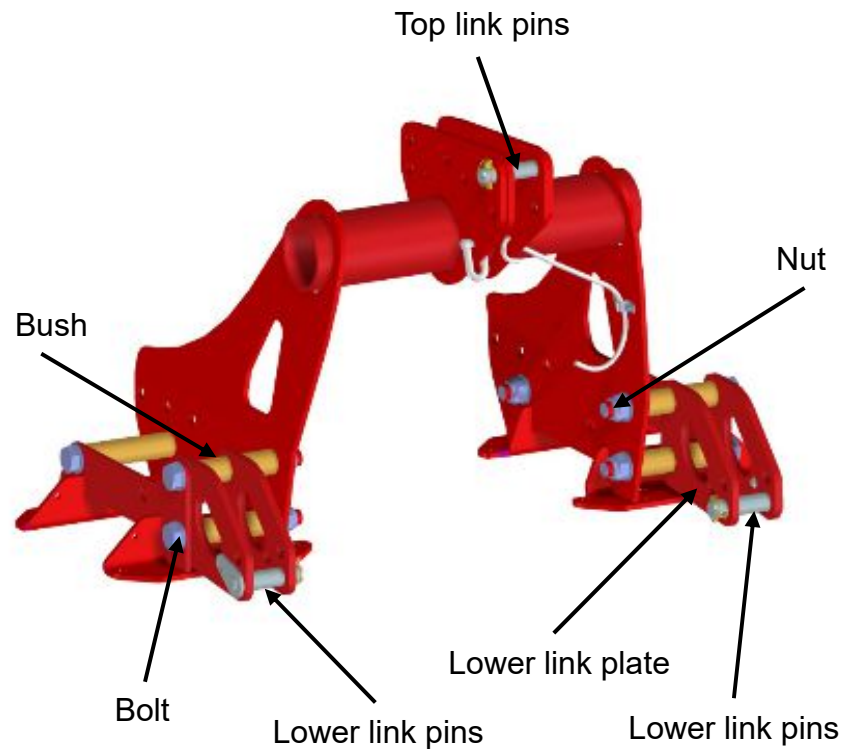

Step 1

- Disassembly the lower pins hitch, including the safety pins
- Undo and remove the nuts
- Remove the bolts, bushes and lower link plates
- Insert the bolts, bushes and lower link plates in accordance with the selected category
- Tighten the nuts to a tightening torque of **1400 Nm**
- Insert the lower link pin from the selected category
- Secure the lower link pin using the linchpin
- Replace the top link pin in accordance with the selected category
- Secure the top link pin using linchpin

Getting started

New version headstock

Connecting power harrow to tractor

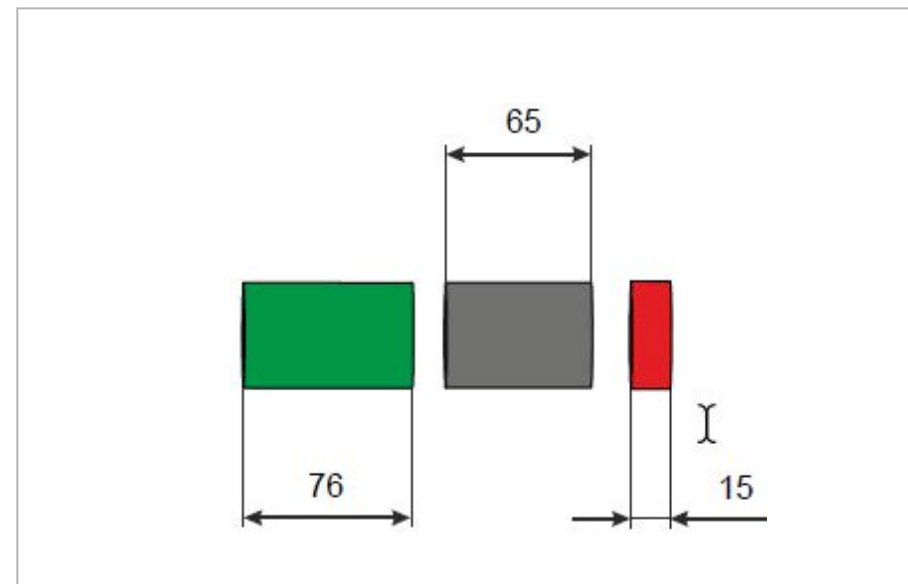
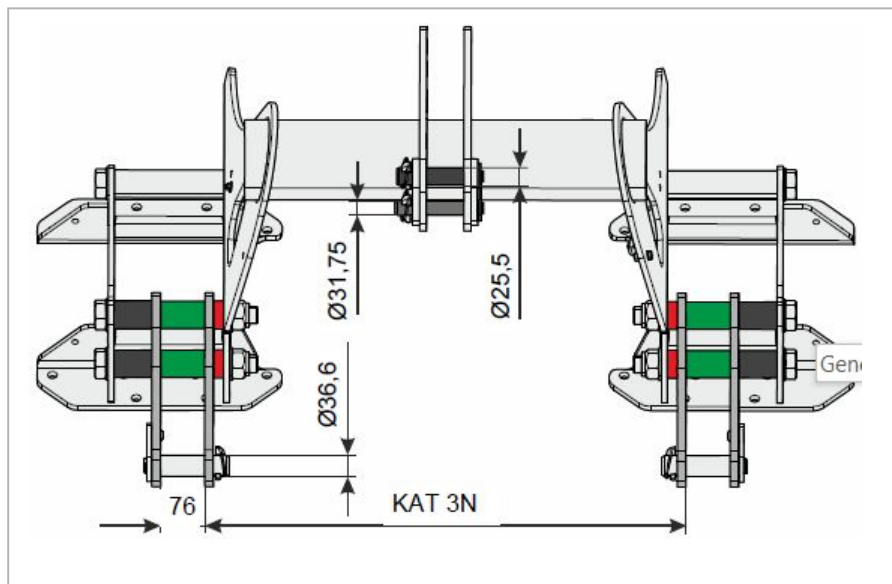
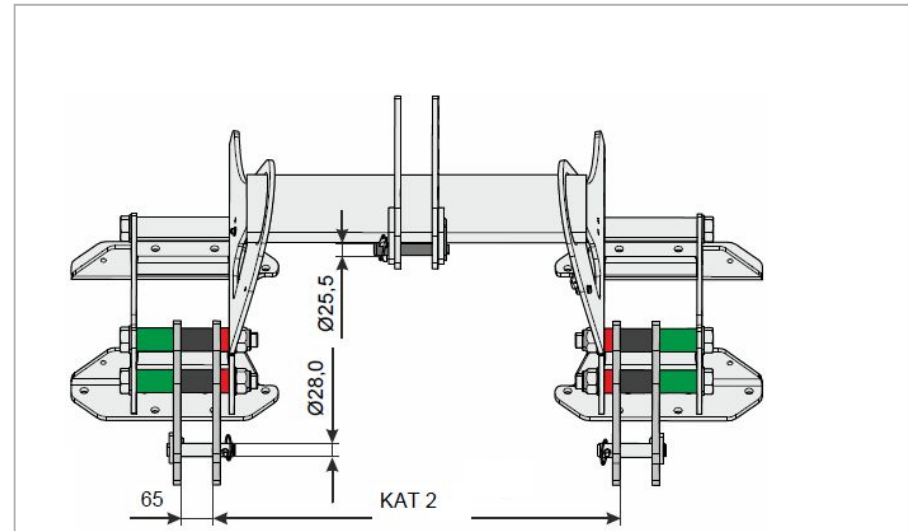
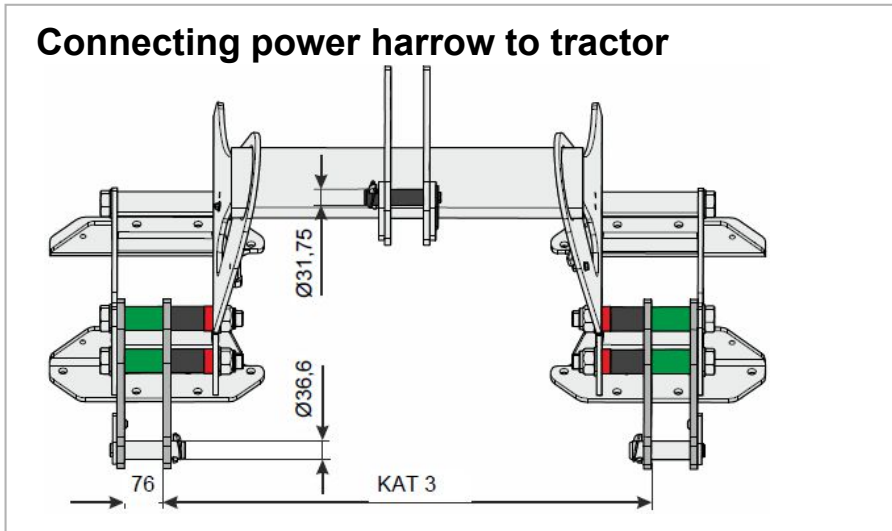

Getting started

Connecting power harrow to tractor

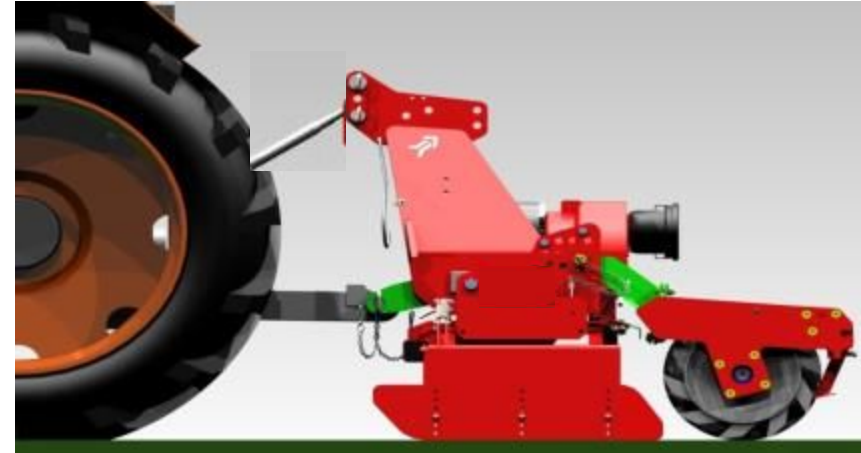
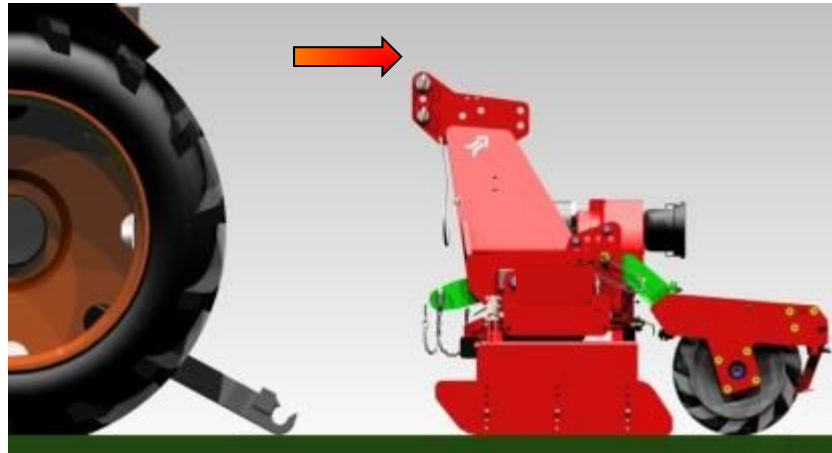

Step 2

- Approach the tractor to the power harrow, while is in parking position , with the lower hitch arms lowered
- Lift up the lower hitch arms until are fully engaged on the spherical joints
- Disassembly the top link pin including the safety pin
- Insert the top link bar , then insert again the top link pin and the safety pin.

Maintenance and Troubleshooting

Adjusting side deflectors

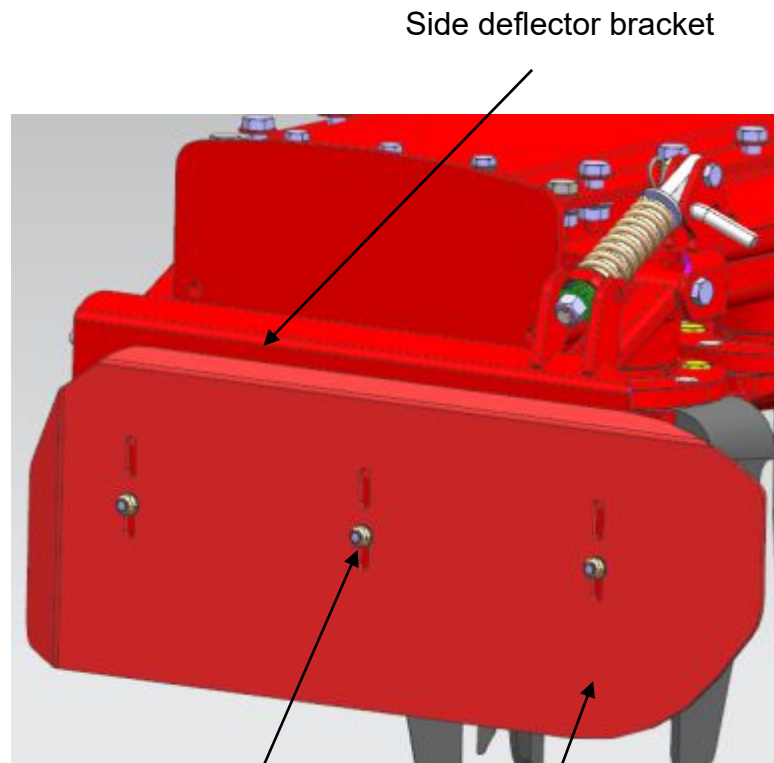

Tighten 40 Nm



- Side deflector must be adjusted so that a wall of earth is not created at the sides of power harrow
- Movement with spring-protected parallelogram
- The position of the shield-extension depends on the working depth of power harrow.

Replacing tines

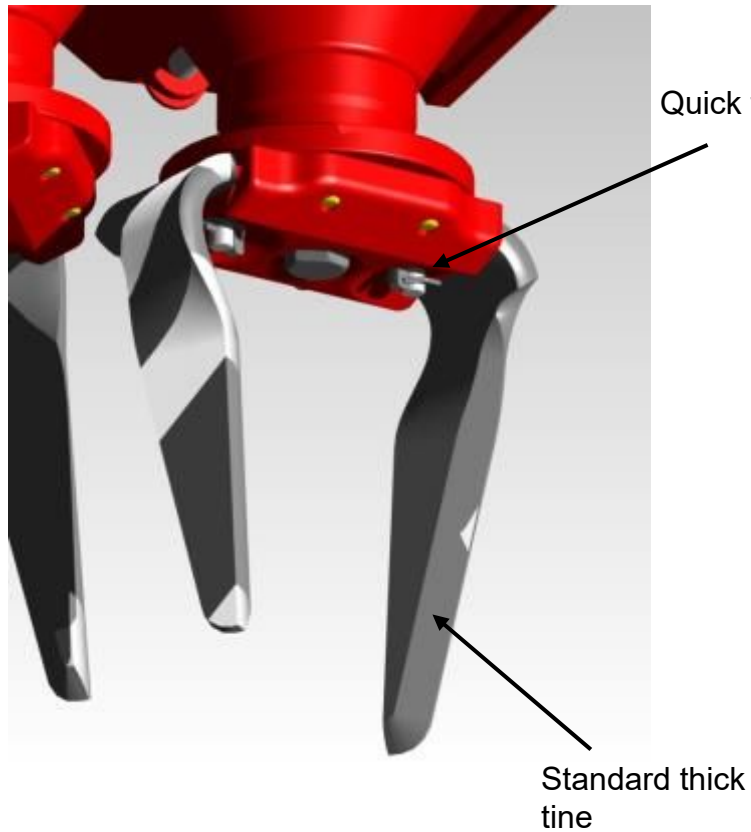

Quick fit tine



- Rotate the quick safety pin ring to unlock the pin itself



- Remove the quick safety pin.

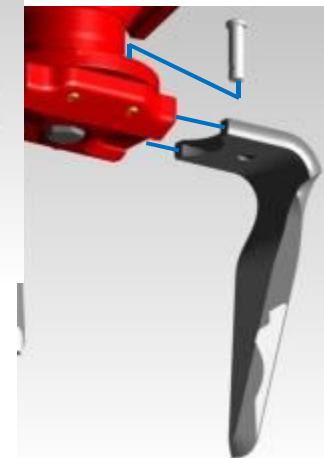

- Remove the tine locking pin, then slide sideward the tine.

Maintenance and Troubleshooting

New „Bevel“ gearbox

Changing gearbox speed

- To change the working speed follow carefully the following instructions.



PTO shaft cover

Gearbox

Changing gearbox speed Step 1

- Open the PTO shaft cover , then loosen the hexagonal head screws.
- Remove the screws and Gear-Box cover
- Remove the locking clip and then replace the gears

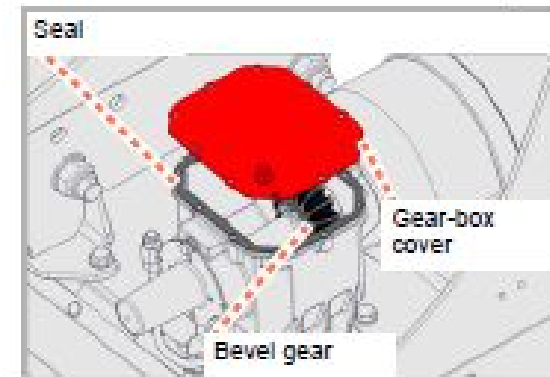

Gear ratio to changing gearbox speed

Model	Input shaft	Output shaft	Rotor speed (rpm) with tractor PTO speed of 1000 rpm
H series 3-3.5-4 m	Z=20	Z=23	344
	Z=23	Z=20	455



After the gearbox speed Changing, the overload protection on PTO must be adjusted only by Walterscheid.

Changing gearbox speed Info & cautions

- Wait until all the moving parts are completely stopped.
- Raise the power harrow and then tilt it forward to prevent oil leakage when disassembling the gearbox cover.
- Lock the tractor hydraulic system to prevent accidental lowering of the linkage.
- Shut off the tractor engine.
- Wait until the oil temperature has cooled down, after the work oil temperature could be very high and there is a high risk of burns.

Maintenance and Troubleshooting

old version gearbox

Changing gearbox speed

- To change the working speed follow carefully the following instructions.



Gearbox

PTO shaft cover

Changing gearbox speed Step 1

- Open the PTO shaft cover , then loosen the hexagonal head screws.
- Remove the screws, the washers and then remove the PTO shaft cover



PTO shaft cover

Washer

Hexagonal head screw

Maintenance and Troubleshooting

old version gearbox

Changing gearbox speed Step 2

- Remove the hexagonal head screws and then remove the gearbox cover and the gearbox gasket.
- Be very careful during gasket dis-assembly and reassembly

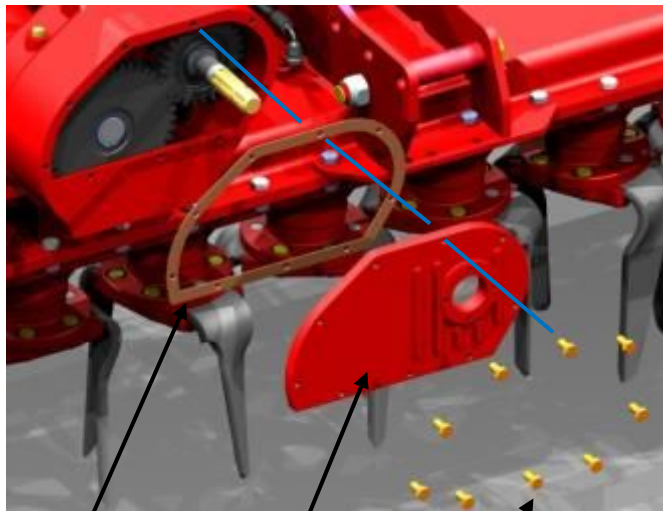

Gearbox gasket

Gearbox cover

Hexagonal head screw Use
threadlocker Loctite Type
243

Tighten 90 Nm



Changing gearbox speed Step 3

- Remove the circlips and then replace the gears

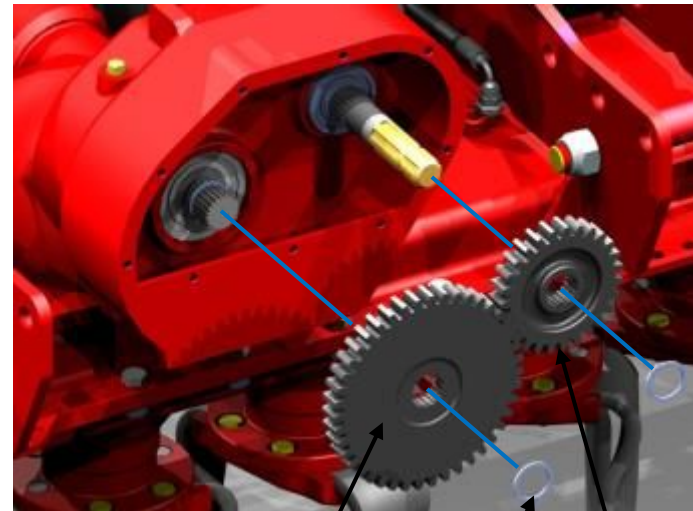

Output gear

Circlip

Input gear

Gear ratio to changing gearbox speed

Model	Input shaft	Output shaft	Rotor speed (rpm) with tractor PTO speed of 1000 rpm
H series 3-3.5-4 m	Z=23	Z=33	336
	Z=24	Z=32	362
	Z=27	Z=29	450



After the gearbox speed Changing, the overload protection on PTO muss be adjusted only by Walterscheid.

Changing gearbox speed Info & cautions

- Wait until all the moving parts are completely stopped.
- Raise the power harrow and then tilt it forward to prevent oil leakage when disassembling the gearbox cover.
- Lock the tractor hydraulic system to prevent accidental lowering of the linkage.
- Shut off the tractor engine.
- Wait until the oil temperature has cooled down, after the work oil temperature could be very high and there is a high risk of burns.

Maintenance and Troubleshooting

Changing tine carrier - Overview

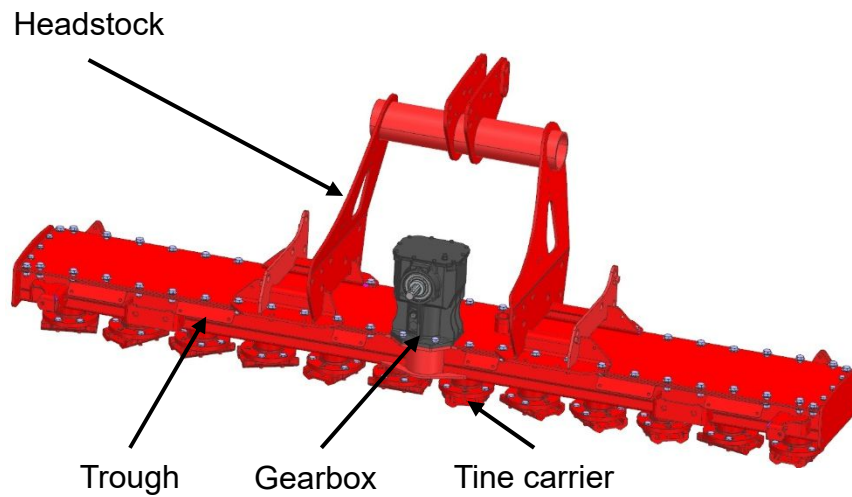

New „Bevel“ gearbox

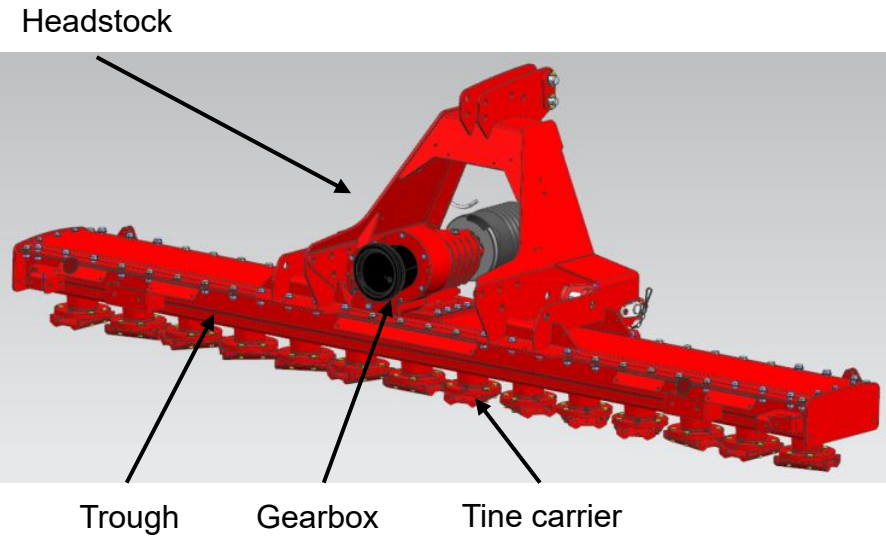

Old version gearbox

Maintenance and Troubleshooting

New „Bevel“ gearbox

Changing tine carrier Step 1

- Loosen the self locking nuts.
- Remove the hexagonal head screws and the washers

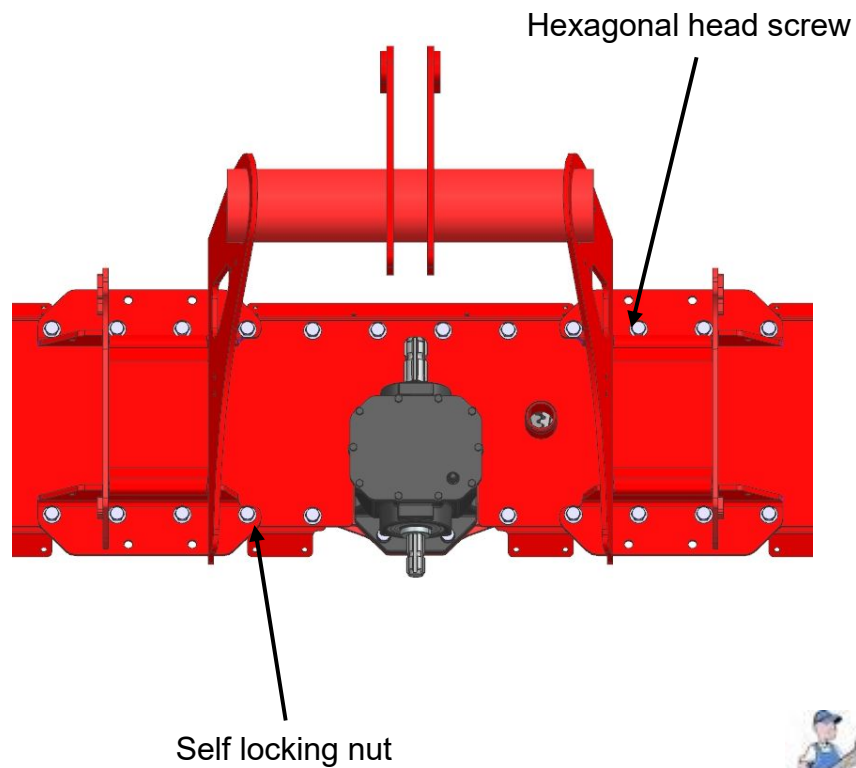

Tighten 300 Nm



Changing tine carrier Step 2

- Lift up the headstock

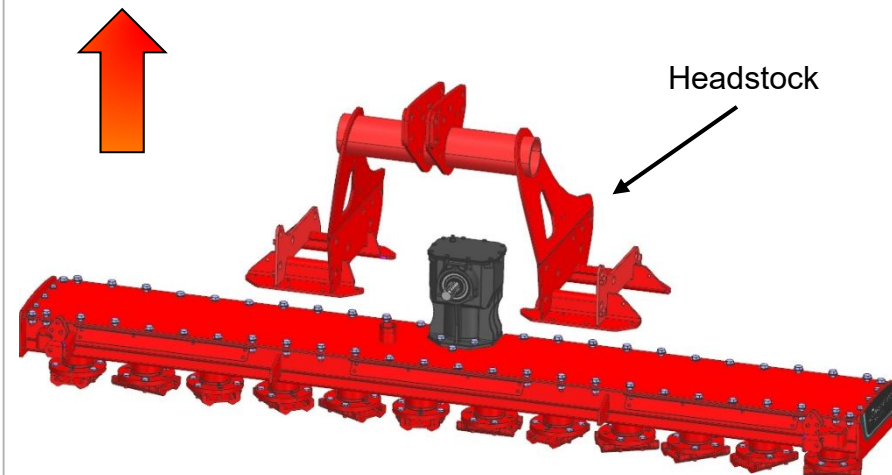

New „Bevel“ gearbox

Changing tine carrier Step 3

- Loosen the hexagonal socket cylindrical head screw

Hexagonal head screw use permabond 118

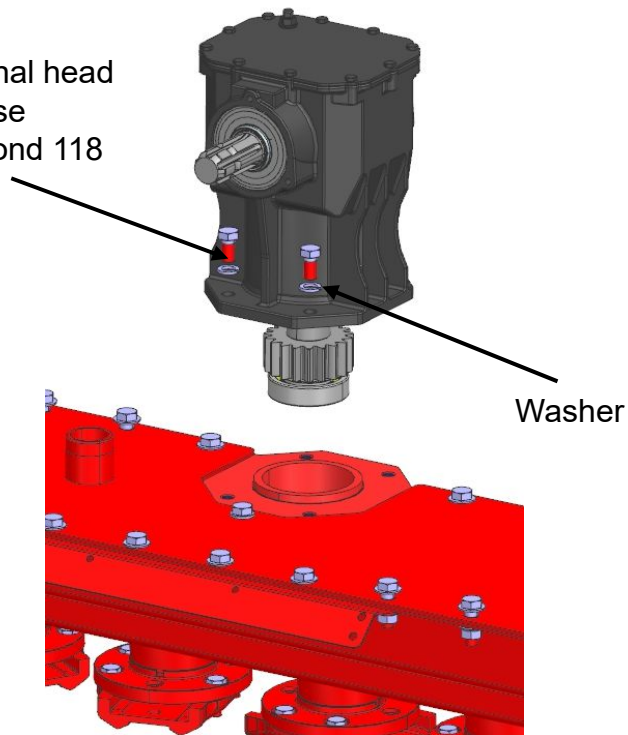

Tighten 160 Nm



Changing tine carrier Step 4

- Lift up the gearbox and remove the gearbox base



Gearbox

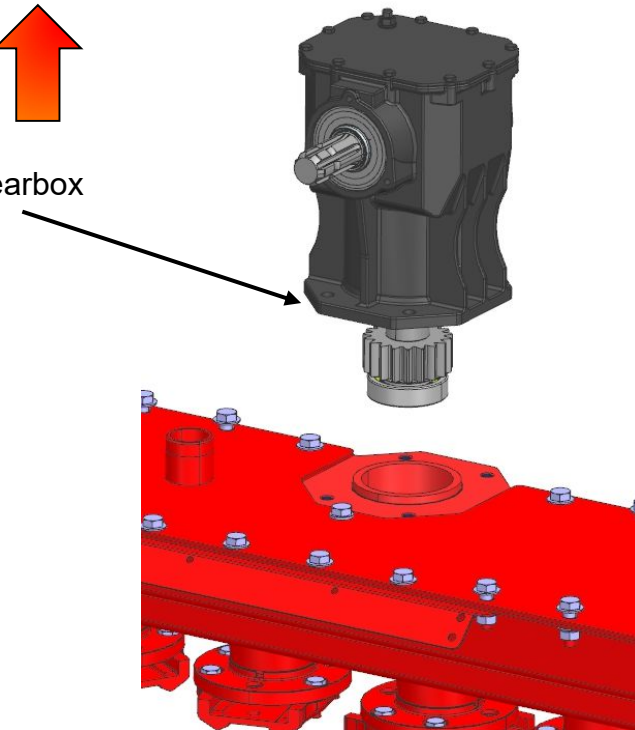

New „Bevel“ gearbox

Changing tine carrier Step 5

- Loosen all the self locking nuts, then remove the screws and the washers
- Loosen the hexagonal head screws

Tighten 85 Nm

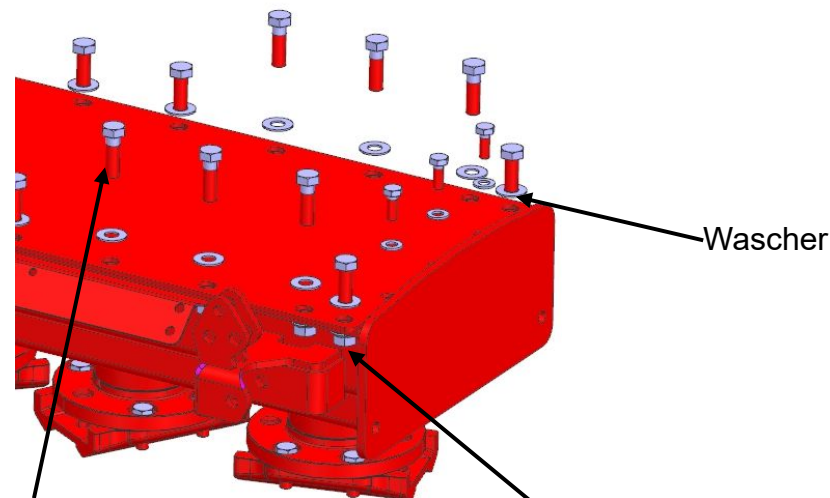

Wascher

Hexagonal head screw
Use threadlocker loctite
type 243

Self locking nut

Tighten 300 Nm



Changing tine carrier Step 6

- Remove the upper trough casing then remove the transmission shaft

Upper trough casing

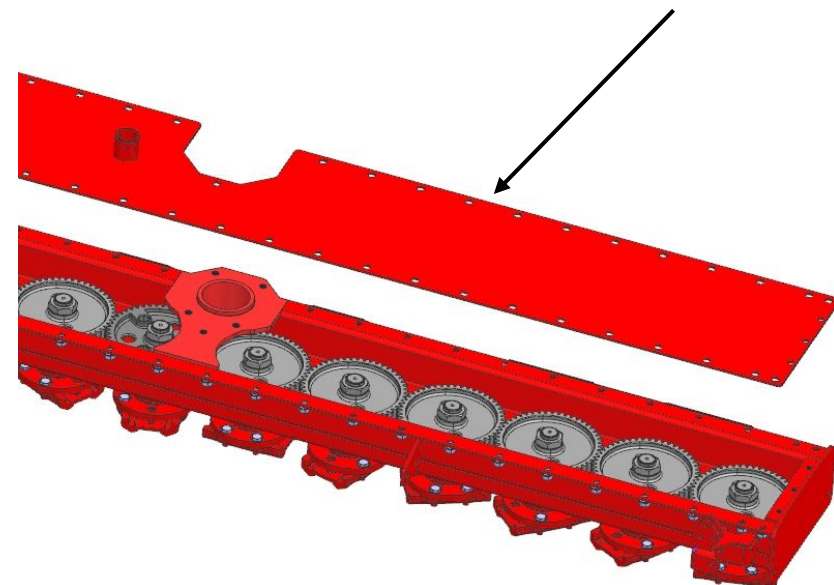

Maintenance and Troubleshooting

Old version gearbox

Changing tine carrier Step 1

- Loosen the self locking nuts.
- Remove the hexagonal head screws and the washers

Washer

Hexagonal head screw

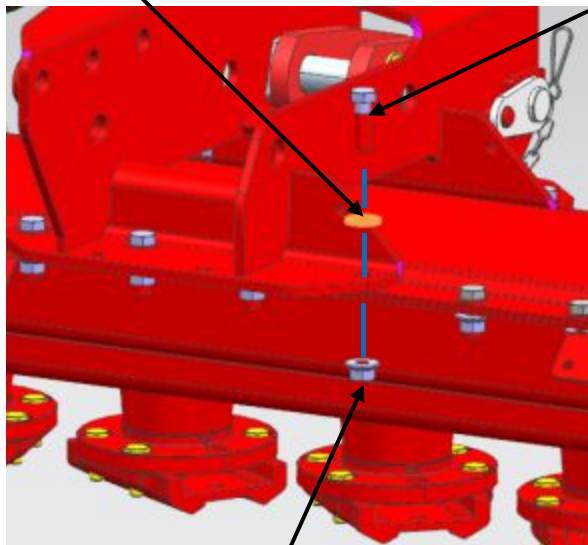

Self locking nut

Tighten 300 Nm



Changing tine carrier Step 2

- Lift up the headstock

Headstock

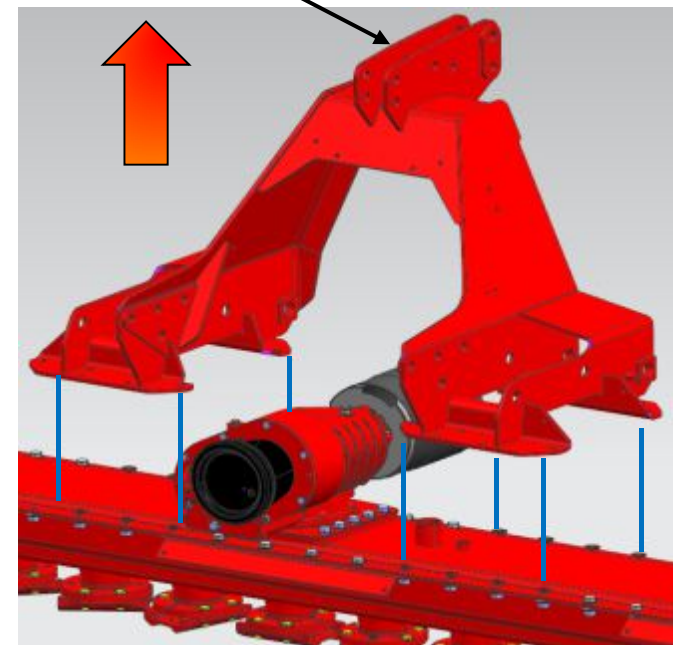

Maintenance and Troubleshooting

Old version gearbox

Changing tine carrier Step 3

- Loosen the hexagonal socket cylindrical head screw

Hexagonal head screw use permabond 118

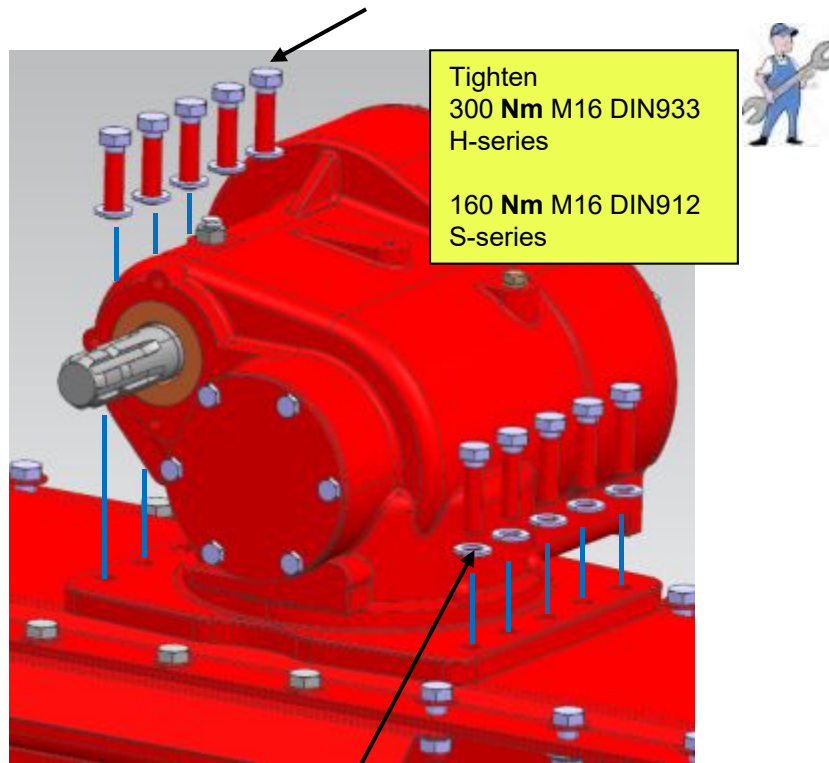

Washer

Changing tine carrier Step 4

- Lift up the gearbox and remove the gearbox base

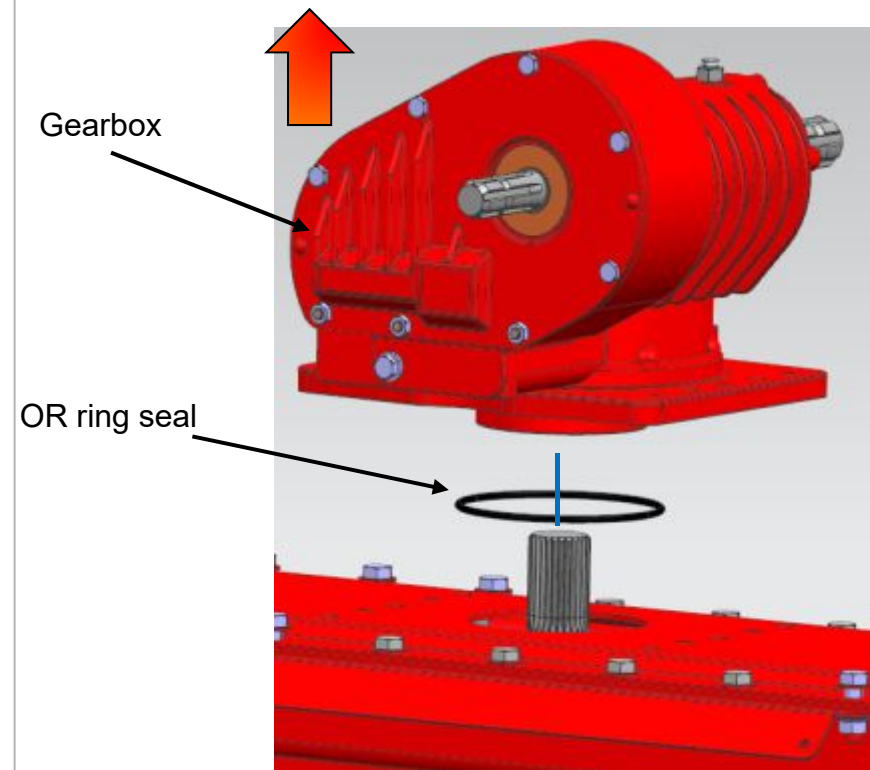

Changing tine carrier Step 5

- Loosen all the self locking nuts, then remove the screws and the washers
- Loosen the hexagonal head screws

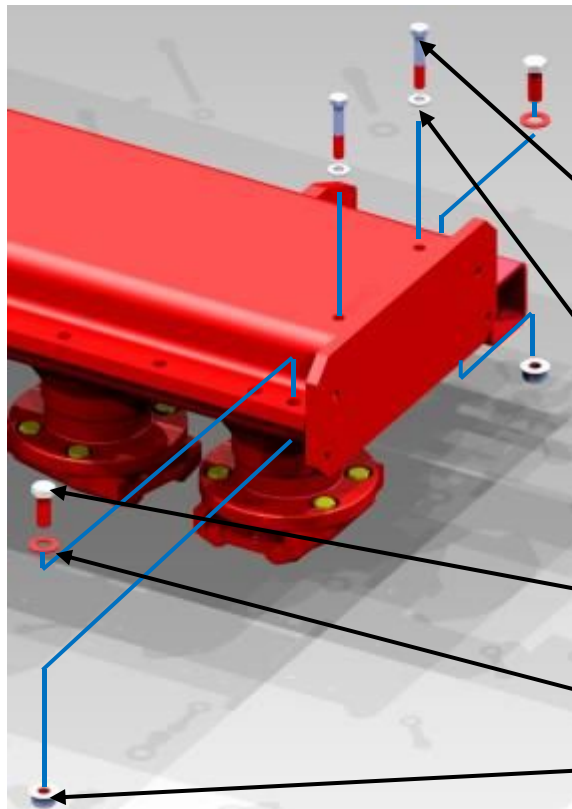

Tighten 85 Nm

Hexagonal head screw
Use threadlocker loctite type 243

Wascher

Transmission shaft

Hexagonal head screw

Washer

Self locking nut

Tighten 300 Nm



Changing tine carrier Step 6

- Remove the upper trough casing then remove the transmission shaft

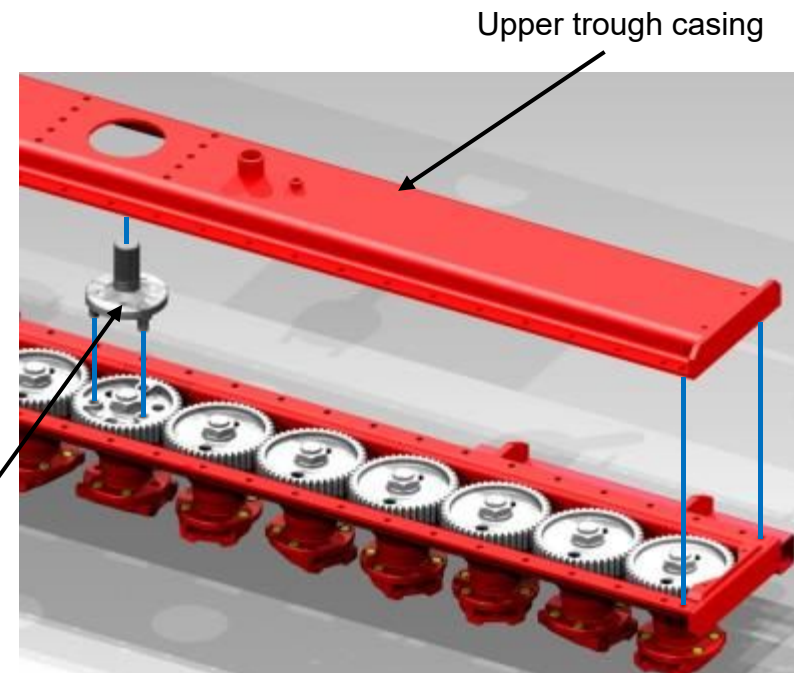

Maintenance and Troubleshooting

Changing tine carrier Step 7

- Loosen the upper nut, then remove the gear

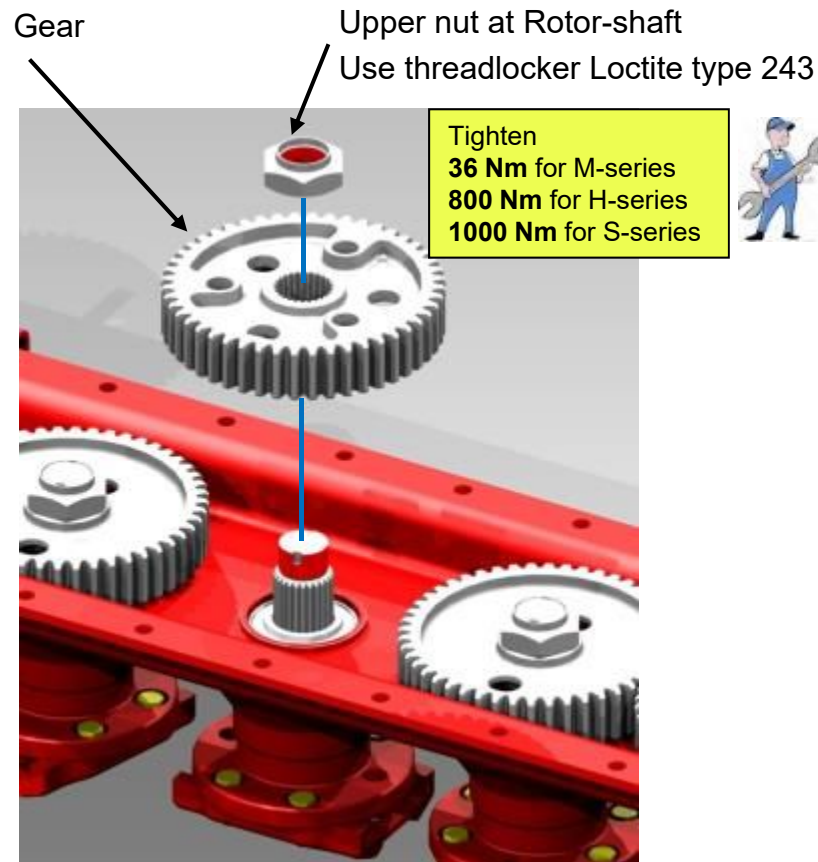

Changing tine carrier Step 8

- Remove the hexagonal head screws, then remove the quick tine holder, the lower hexagonal head screw and the spring washer.

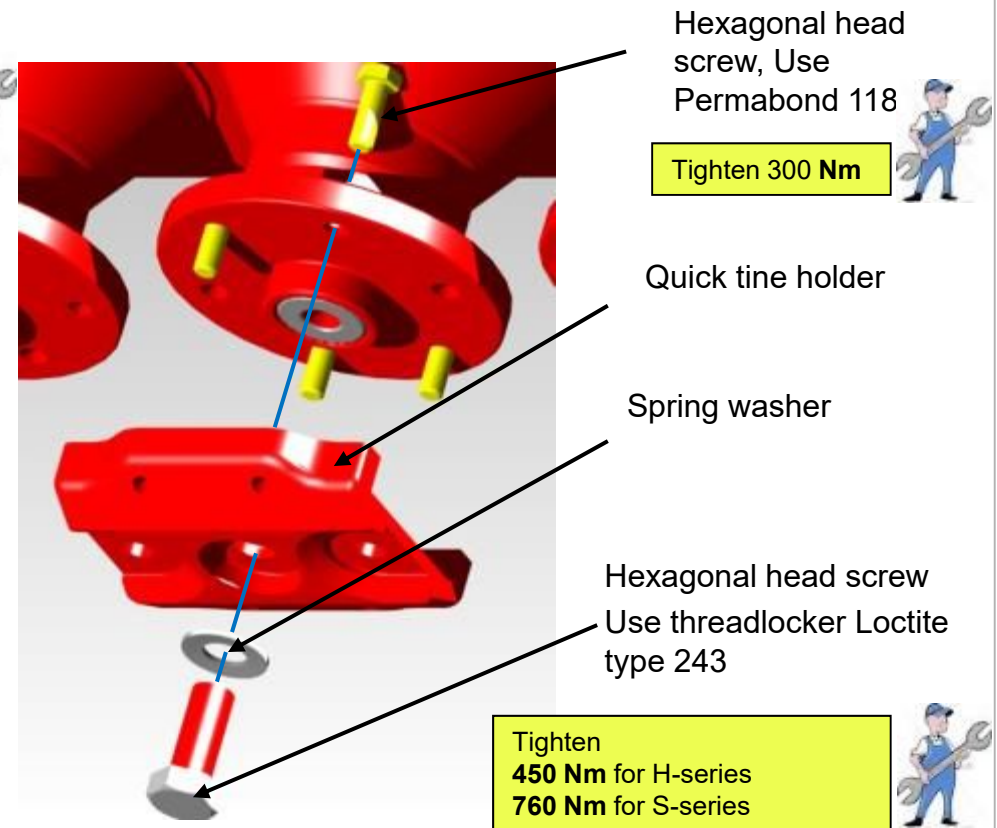

Maintenance and Troubleshooting

Changing tine carrier Step 9

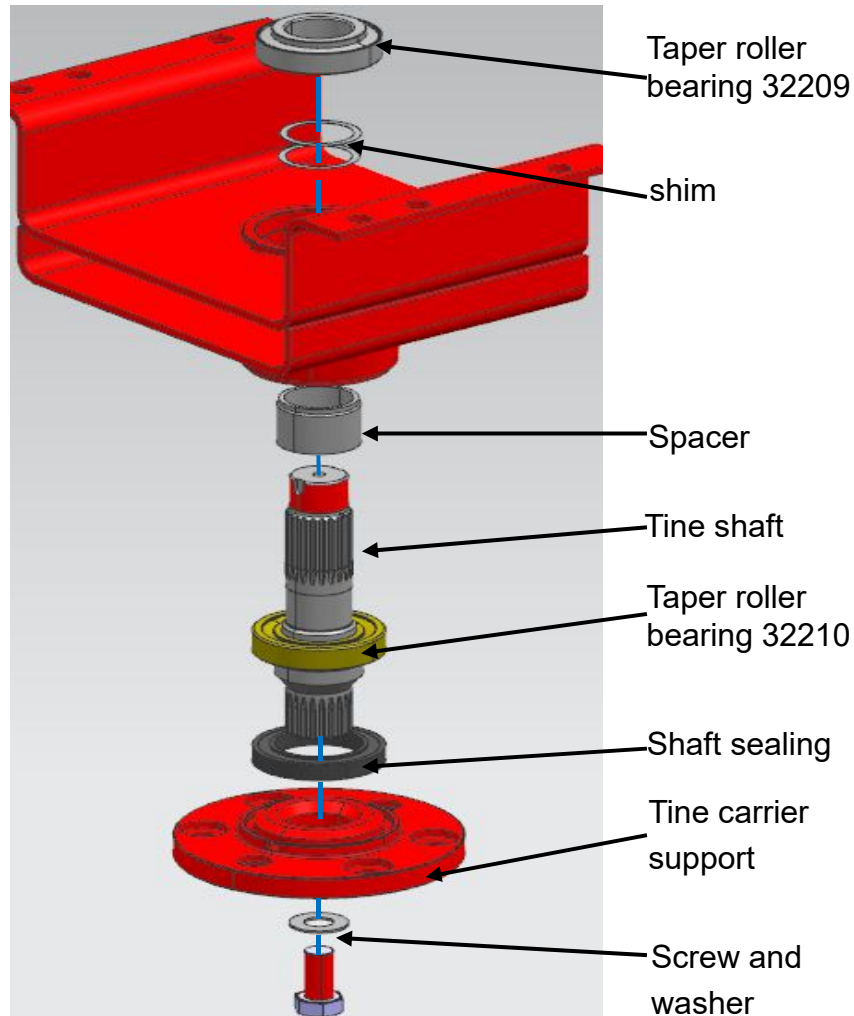

- Use tool (1) to demount the shaft sealing and the bearings from the rotor support
- Use tool (2) to demount the tine shaft from the rotor support



IMPORTANT NOTE:

During the tine carrier disassembly and re-assembly **ALWAYS** use proper tools to avoid damages to shaft seals and taper roller bearings.

ALWAYS keep the parts clean and lightly greased.

New „Bevel“ gearbox

Checking gearbox oil level

Oil level indicator

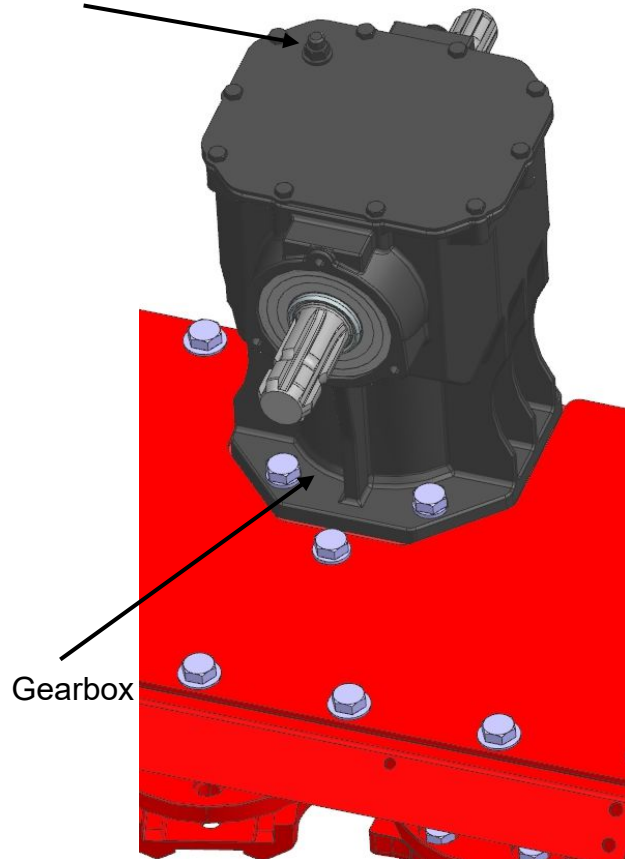

Gearbox

- The machine must be in horizontal position before checking the oil level.
- Remove the oil level indicator, the oil level must match the mark on the level shaft.
- If necessary, replenish the transmission oil using a funnel
- Insert the oil level indicator
- Check the tightness of the oil level indicator after each maintenance
- First oil change: 30 hours
- Oil change interval: 200 hours

Model	Oil type	Quantity
H series 3-3.5-4 m	Mineral oil SAE 140-EP JSO V6 460 DIN 51517	2.1 L

Old version gearbox

Checking gearbox oil level

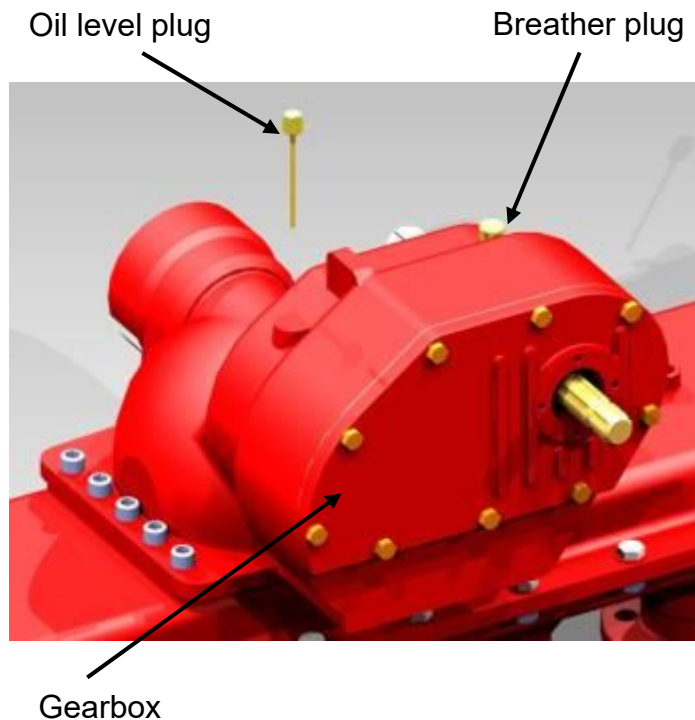

- The machine must be in horizontal position before checking the oil level.
- Remove the level oil plug , the oil level must match the mark on the level shaft.
- If necessary, top up oil level using a funnel
- First oil change: 30 hours
- Oil change interval: 200 hours

Model	Oil type	Quantity
H series 3-3.5-4 m	Mineral oil SAE 140-EP JSO V6 460 DIN 51517	6.5 L

Maintenance and Troubleshooting

Checking trough grease level

- The machine must be in horizontal position before checking the transmission grease level.
- Remove the filler cap.
- If necessary, top up grease level.

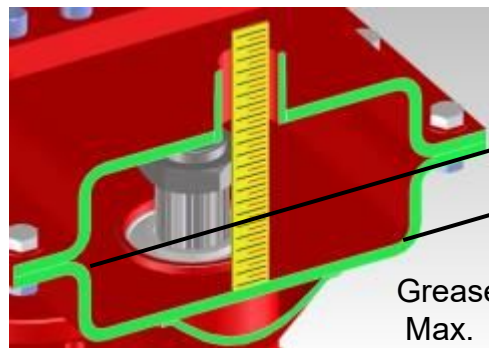
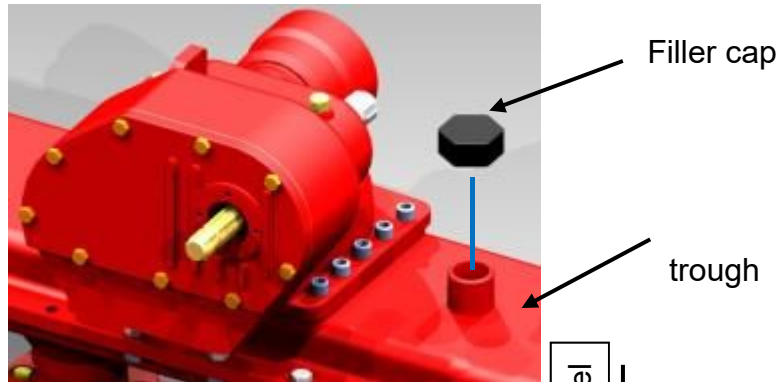

Grease level:
Max. 16 mm
Min. 9 mm

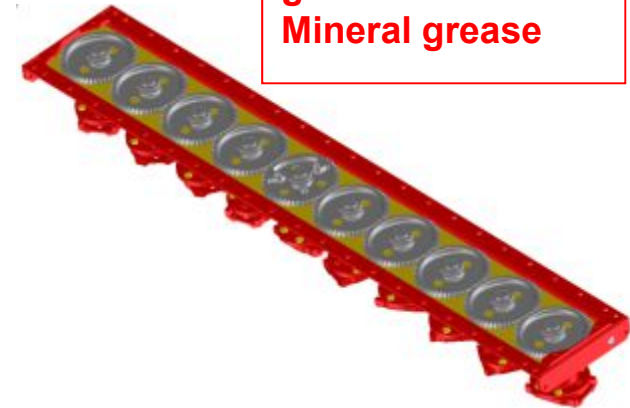

Att.on!!
We advice do not mix up
The Synthetic grease with Mineral grease

Grese type: Lithium grease SAE 140 EP NLG100
GOOK DIN 51826

Model	Quantity (kg) for each trough
H-series 3 m	18 kg
H-series 3.5 m	21 kg
H-series 4 m	24 kg

Attachment

Gearbox Oil Characteristic	
Grade	ISO VG 320
Description	EP Gear Oil
Specifications	ANSI/AGMA 9005-94
Approvals	DIN 51517 Part 3 - CLP
Homologations	ISO-L-CKD
Applications	Gearbox

General Grease Type	
Grade	EP NLGI 00 G00K
Description	Multipurpose Grease
Specifications	DIN 51826
Approvals	K2K-20
Applications	Roller Bearings Plain Bearings Trough Lubrication



IMPORTANT NOTE

Do not mix Oils of different types and specifications : this could cause malfunctions and serious damages to items



IMPORTANT NOTE

Do not mix Greases of different types and specifications and do not use Greases with lower specifications

Attachment

Bolts tightening torque tables

ISO table fine thread bolts			
Bolt size	Bolt quality		
	8.8	10.9	12.9
	Tightening torques in Nm		
M6	9,9	14	17
M8	24	34	41
M10	48	68	81
M12	85	120	145
M16	210	290	350
M20	425	610	710
M24	730	1050	1220
M12x1.5	75	89	125
M14x1.5	125	150	205
M16x1.5	190	220	310
M18x1.5	270	320	450
M20x1.5	380	450	630
M22x1.5	510	600	850
M24x1.5	670	800	1120
M27x1.5	990	1170	1640



Attachment

Resetting operation of tine carriers' "TIMING",



60° 45° 30° 75° 0° -75° -30° -45° -60° -15°

Timing process:

1. Remove all tine carriers.
2. Assemble one central tine carrier and rotate it so that the tines are in-line with the axis of the trough (reference rotor).
3. Assemble the two adjacent tine carriers with a phase angle of between +5° and +15°. Procedure: position the tine carrier at 90° to the reference tine carrier and rotate it until you find the **first possible** assembly position. **The phase angle must not exceed 15°**. If it is not possible to find a position between 5° and 15° rotate the tine carrier 180° and try again. NB The alignment of three adjacent tine carriers must be convergent (or divergent), not parallel. (Fig.1)
4. Rotate the newly assembled tine carrier so that it is in-line with the trough (as in step 2)
5. Assemble the next adjacent tine carrier so that the phase angle is between -5° and -15°. (Fig.2)
6. Proceed in this way for all remaining tine carriers.

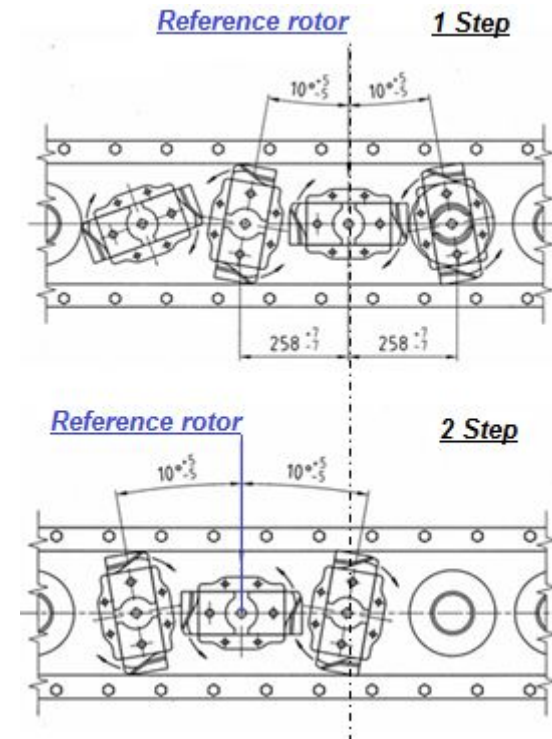

Attachment

Test-Stand in the factory



Check points:

- The type and the quantity of oil are right
- Test time: Min. 30 mins
- During the test, if the noise development is normal (Noise level < 70 dbA)
- After 30 mins test, the temperature in the bearing position don't allow above 90 °C. The checking follow every bearing
- After 30 mins test, the temperature in the Gearbox don't allow above 95 °C