

MA000726115 Comer Disc clutch D44 Calibration mode

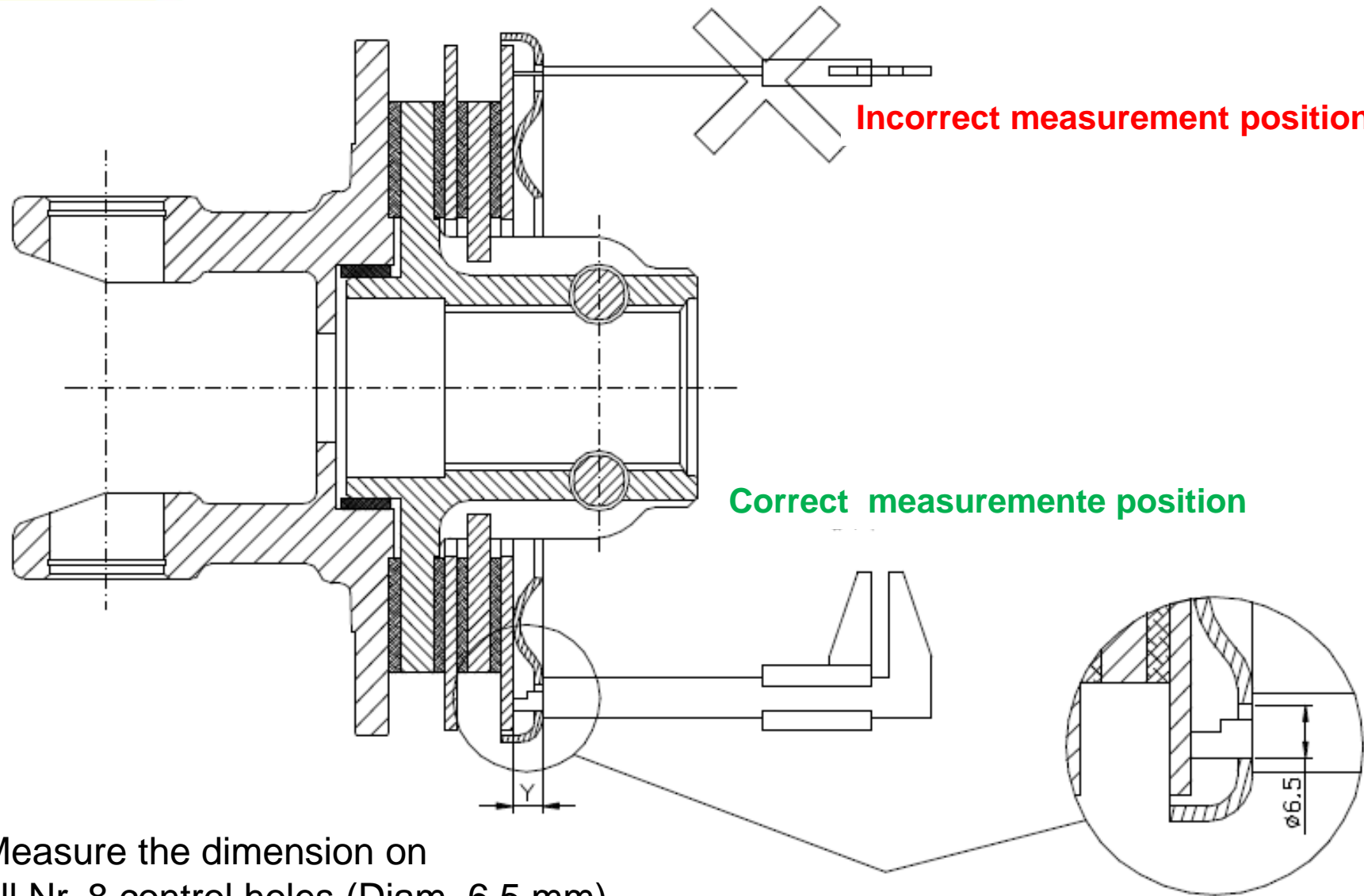

Measure the dimension on
all Nr. 8 control holes (Diam. 6.5 mm)

MA000726115 Comer Disc clutch D44 Adjustment table

D4

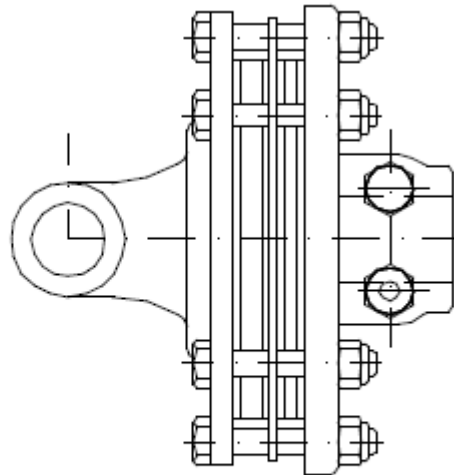

<i>Y. mm</i>	From N*m
5.7	120
5.2	150
4.7	180
4.3	200

Correct measurement

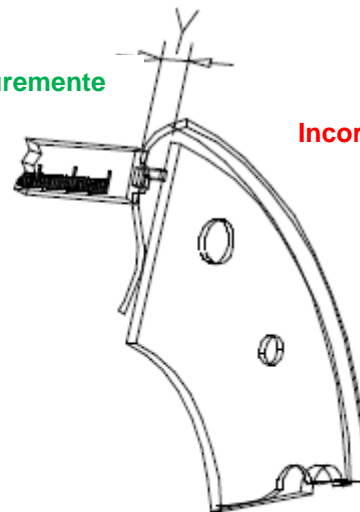

Incorrect measurement

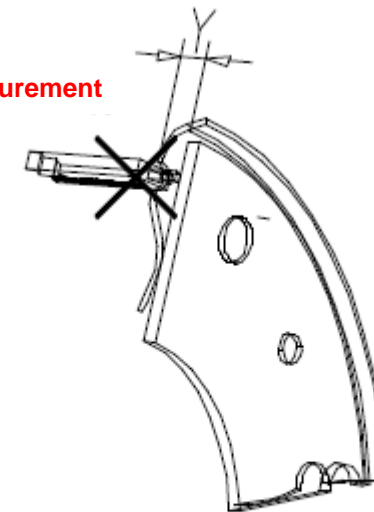

Y = height of the measurement holes