

Service manual CTC



Date March 2018

Subject **Service training CTC**

Details CTC range

Table of contents

1. Overview	3	5. Adjustments	19
2. CTC	4	5.1 Before transport	19
3. Generality	5	5.2 Before work	20
3.1 Generalities on tine	5	5.3 Working depth	21
3.2 Tine flexibility	6	5.4 Parallel lifting	22
3.3 Tine holder	7	5.5 Depth with parallelogram	23
3.4 Tine protection	8	5.6 Depth with double disc gang	24
3.5 CTC tine : Bolted shares	9	5.7 Front wheels	25
3.6 CTC tine : Knock-on	10	5.8 FCD/FMD on CTC	26
3.7 CTC tine : Carbide equipment	11	5.9 Levelling discs and levelling tines	27
3.8 CTC Tine : Deflectors range	12	5.10 Combi disc	28
4. Accessories	13	5.11 Lateral disc & tines	29
4.1 Linkage	13	5.12 Double disc gang	30
4.2 Wheels and wagon	14	5.13 Actipack/Actiring knives	31
4.3 Control wheels	15	5.14 Actiflex	32
4.4 Front discs	16	5.15 U-bolts on rollers	33
4.5 Rear accessories	17	5.16 Tyres pressure	34
4.6 Rollers	18	6. Maintenance and lubrication	35
		6.1 Greasing	35
		6.2 Wearing parts on tines	36
		6.3 Wearing parts on accessories	37
		6.4 Wearing parts on rollers	38
		6.5 Wearing bush	39
		6.6 Depth cylinders	40
		7. Hydraulic diagrams	41 -
			45

1. Overview



Front wheels depth control

Front Cutting Disc / Front Mixing Disc

3 rows of tines
- 270 mm spacing
- 870 mm under beam clearance
- 50 to 300 mm working depth

Rear accessories with parallelogram

Roller and depth control



- Frame 100x100mm
- Central frame 200 x 200mm
- 2 folding sections
- Under beam clearance the frame 870 mm
- CLC tine
- Non-Stop safety device with spring blade or share bolts system
- Tines spacing : 270 mm
- Up to 30 cm depth

	CTC					
	Fold					
Models	CTC 427	CTC 420	CTC 527	CTC 520	CTC 627	CTC 620
Working width (m)	4,00	4,00	5,00	5,00	6,00	6,00
Number of tines	15	17	17	23	21	29
Transport width (m)	3					
Frame (mm)	100x100x8					
Linkage	Cat III & IV					
Working depth (cm)	5 - 30 cm					
Number of rows	3 spacing 270mm	4 spacing 200mm	3 spacing 270mm	4 spacing 200mm	3 spacing 270mm	4 spacing 200mm
Under beam clearance (mm)	870					
Weight (with NS safety tine/cage roller/ 3 rows 270 mm)	4550		4800		5200	
Horsepower Mini/Maxi (Hp)	160/ 300		180/ 350		200/ 400	
Homologation (DREAL / TÜV)	Yes					

* NS = Non-Stop

3.1 Generalities on tine

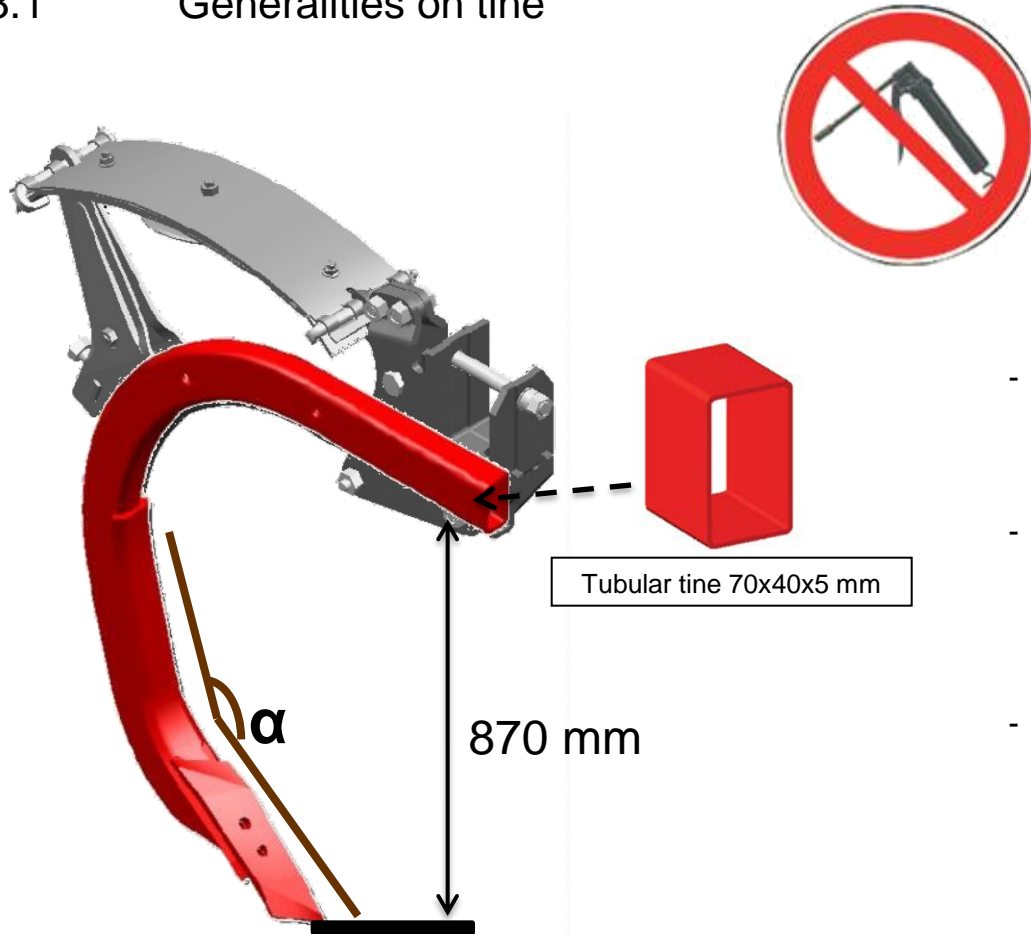

- Robust design with no grease nipple at all = **no maintenance**
- The tine made up of two working angles ensures effective penetration and ensures efficient and homogeneous mixing.
- The height under beam clearance of 870mm is ensuring blockage free operation

3.2 Tine flexibility



- All parts from the tine are heat treated
- The KVERNELAND tubular tine allows flexibility and a light weight.
- High vibration capacity providing intensive crumbling effect.
- Design made out of a tube enabling the C shank to move side ways +/- 14 cm with the short tine, and +/- 20 cm with the long tine.
- Complete Non-Stop tine, without share, is only 35 kg

3.3 Tine holder



- The tine holder is a patented system. The U of the holder is clamped to the frame by a single bolt
- To ensure a good tightening (pinch) and to maintain the elements in place on the frame, the torque must be maintained at 600 Nm.
- This U is formed in a plate of 100mm wide; it provides a good base of the tine on the tube.
- The light tine can be easily removed to adapt the machine to the working conditions or tractor available.

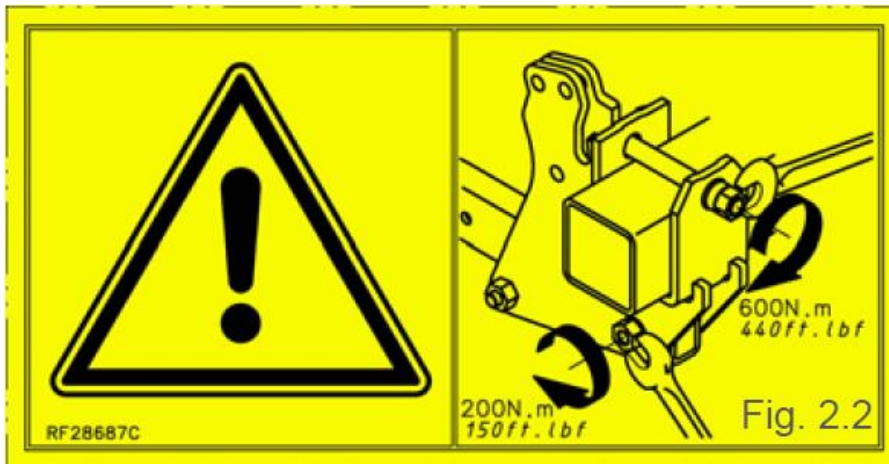

3.4 Tine protection

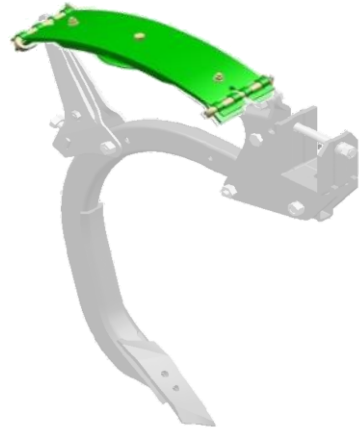



Shear Bolted security

- The shear bolt leg design is providing a Vibromat effect
- A 2T pressure is applied at the breaking point to ensure a clean breaking of the bolt
- the tine being made from a tube is flexible enough to allow the point to trip 10 cm back before the bolt breaks.

Spring blade	Release effort	View of spring	CTC
HD KK084304	640 kg		✓
HD+ KK089680	640 kg		✗

3.5 CTC tines : Bolted shares

Types	Description
<p data-bbox="360 344 561 379">Plough point</p> 	<p data-bbox="1212 344 1549 379">Standard share 60mm</p> <ul data-bbox="1189 462 1570 605" style="list-style-type: none"> - Reversible plough share - Low cost prices - Heat treated
<p data-bbox="360 772 685 808">Plough point + wings</p> 	<p data-bbox="1141 772 1622 808">Standard share + 300mm wings</p> <ul data-bbox="1120 891 1638 1033" style="list-style-type: none"> - Adapted to shallow working depth - Good mixing effect - Heat treated





3.6

CTC tine: **KNOCK-ON**





Fast and easy metal change







Types	Description
KO 80 	<ul style="list-style-type: none"> - Width 80 mm - Used to work 10 to 35 cm depth
KO 150 	<ul style="list-style-type: none"> - Width 150 mm - Used to work 8 to 25 cm depth
KO 250 	<ul style="list-style-type: none"> - Width 250 mm - Used to work 3 to 15 cm depth
KO 320 	<ul style="list-style-type: none"> - Width 320 mm - Used to work 3 to 15 cm
KO 80 + Quantum 	<ul style="list-style-type: none"> - Width 345 mm - Used to work 3 to 15 cm

3.7 CTC tine : Carbide equipment

- Extremely long life
- Resist against stony conditions

Types	Descriptions
<p>Tiger point 80 mm</p> 	<ul style="list-style-type: none"> - Width 80 mm - Used to work 10 to 35 cm depth
<p>Tiger point 80 mm + Quantum</p> 	<ul style="list-style-type: none"> - Width 345 mm - Used to work 3 to 15 cm

3.8 CTC tine : deflectors range

Range of deflectors					
	65 mm tine protection	80 mm deflector	80 mm twisted deflector	100 mm deflector	100 mm twisted deflector
Models available	All	All	All	All	All
Width (mm)	65	80	80	100	100
Depth (cm)	10 to 35	3 to 30	3 to 30	3 to 15	3 to 15
Mixing effect	✓	✓✓	✓✓	✓✓✓	✓✓✓

4.1 Linkage



Hydraulic parallel lifting



Ball coupling
ø 80 mm



Fix eye
ø 50 mm



Pivoting pulling
eye ø 50 mm

The machine can be equipped with a pulling eye bolted on the draw bar:

- the machine is mounted with a hydraulic cylinder in order to lift it parallel to the soil.



Simple telescopic bar



Cross shaft Cat.III and IV

Cross shaft required with a simple telescopic bar

4.2 Wheels and wagon

2 different sizes of tyres is possible:

- 400/60 R 15,5
- 480/45 R 17



Wagon connected to the frame with 60x125 cylinder. It ensures the lifting.

CTC equipped with a rear accessory and roller :

- The roller provides depth control.
- The wagon is raised during work.

the machine is equipped with double disc gang :

- Depth is controlled by the wheels of the wagon with additional hydraulic stop valve.

4.3 Control wheels



CTC are equipped with front control wheels as standard :

- Size is 340/55 R 16.
- Regulate working depth on complete width
- Reduce stress on frame
- The setting is done mechanically by turnbuckle.

4.4 Front discs

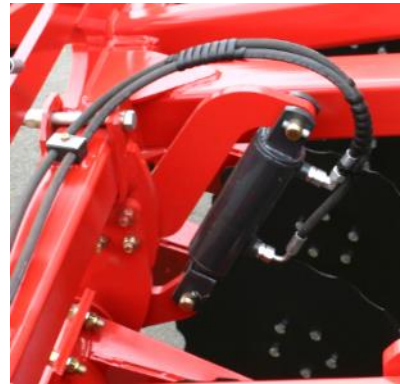

Front Cutting Discs (FCD)



Front Mixing Discs (FMD)





The cutting discs system:

- Located before the first row of tines.
- Discs diameter 450mm
- Notched straight discs, mounted on rubber springs
- Ideal to work in the presence of a large amount of residues
- Cut residues and open the way of the tine.
- Hydraulic depth with cylinders





The mixing discs system:

- Located before the first row of tines.
- Discs diameter 450 mm
- Notched curved discs, mounted on rubber springs
- The arm is the same arm of the Qualidisc farmer and the disc is curved to enable a mixing before tines.
- Straight discs diameter 450mm in the middle (in "A")
- Hydraulic depth with cylinders

4.5 Rear accessories

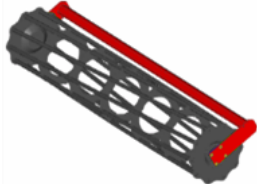
Types	Descriptions
<p>Levelling discs</p> 	<ul style="list-style-type: none"> - Notched disc (Ø 460 mm) - Rubber spring loaded, to follow the ground and protect <ul style="list-style-type: none"> - Depth control provided by roller - Good levelling even with residues
<p>Levelling tines</p> 	<ul style="list-style-type: none"> - Levelling tines system - Depth control provided by roller <ul style="list-style-type: none"> - Good levelling - Effective in light soil
<p>Double disc gange</p> 	<ul style="list-style-type: none"> - Good incorporation of plant residues - Angle adjustable to ensure a good mixing <ul style="list-style-type: none"> - Depth control provided by wheels - For heavy soils or operations in late autumn - Cloddy surface to protect the soil during winter
<p>Combi disc</p> 	<ul style="list-style-type: none"> - Combination of a single disc gang and roller - Good compromise between mixing and levelling - Effective in important plant residues such as maize

4.6 Rollers

Type of roller	Description
Cage roller 	<ul style="list-style-type: none"> - Diameter 550 mm - Great for light soils - Good work in dry conditions - The most economical roller - Weight : 94 Kg/m
Double cage roller 	<ul style="list-style-type: none"> - Diameter 400 mm - Great for light soils - Good compromise between crumbling and depth control - Weight : 169 Kg/m
Actiflex 	<ul style="list-style-type: none"> - Diameter 540 mm - For all soil types - Intensive mixing effect - Good compromise between recompaction and cost - Low sensibility to wearing soil - Weight : 160 Kg/m
Actiring 	<ul style="list-style-type: none"> - Diameter 540 mm - Light to medium soil - Good crumbling power - Sensitive in stony conditions - Weight : 169 Kg/m
Actipack 	<ul style="list-style-type: none"> - Diameter 560 mm - Suitable for soils medium to heavy. - Effective in soil clods, sticky or wet - Very good quality of recompaction - Scrapers anti-jam - Weight : 230 Kg/m

5.1 Before transport



Without parallel lifting

- Put the spindle in a fixed hole of the telescopic bar to lock during the transport. The operation is facilitated by using the second pin provided.
- Set the grey bush so as to have the frame horizontal in transport position, raise the machine and place the second pin in fixe hole.
- Raise the machine completely then fold it.
- Make sure the automatic hook is securely locked.
- Fix the safety fork on the cylinder rod.
- Lower the machine to keep only about 2 to 3 cm distance between the safety fork and the cylinder.

Always close the hydraulic safety valve before transport.



With parallel lifting

- Raise the machine completely then fold it using the hydraulic functions.
- Make sure the automatic hook is securely locked.
- Fix the 2 safety forks on the 2 cylinders rod.
- Lower the machine to keep only about 2 to 3 cm between the safety fork and the rear cylinder. Put the fork in contact to the cylinder at the front.

Always close the hydraulic safety valve before transport.



Never lift completely the machine on transport to allow a suspension effect by the accumulator.

5.2 Before work

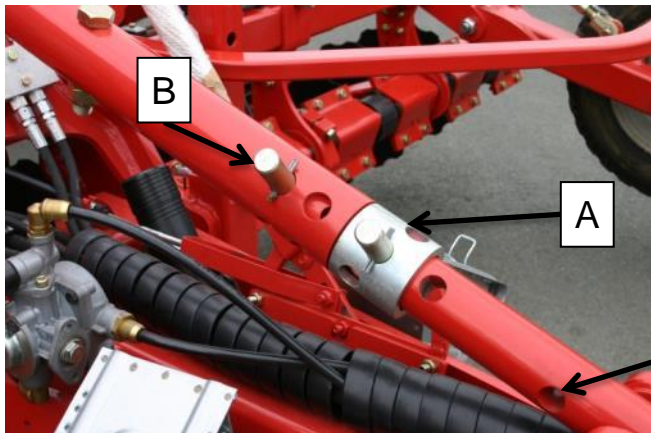

Proceed as follow to switch the machine in work position :

- Remove safety forks (B) and place on the lower hole (C)
- Store them on suitable supports
- Open the hydraulic safety valve
- Lift and unfold machine
- Down the machine to the ground
- Put the adjustment pin in one hole of the grey bush (A)
- Raise the machine
- Adjust grey bush (A) to keep 2-3 cm from telescopic tube

5.3 Working depth

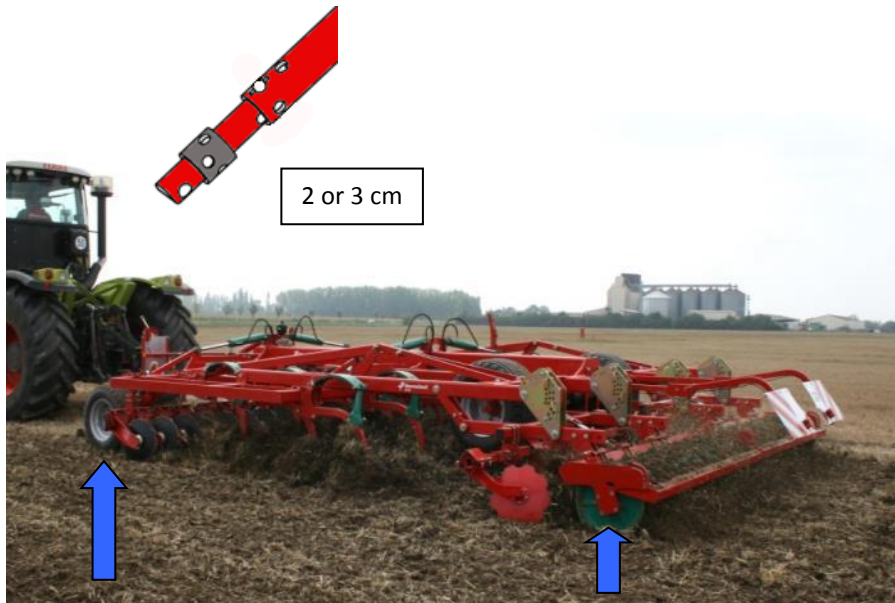

CTC equipped with accessory & roller

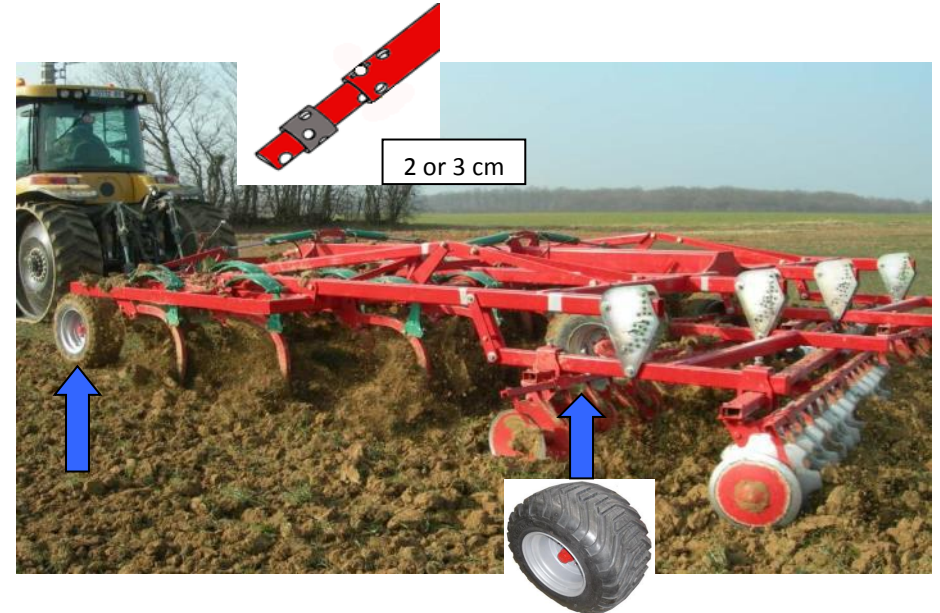



CTC equipped with double discs gang

There are 2 different systems to control the depth, depending of the rear accessories

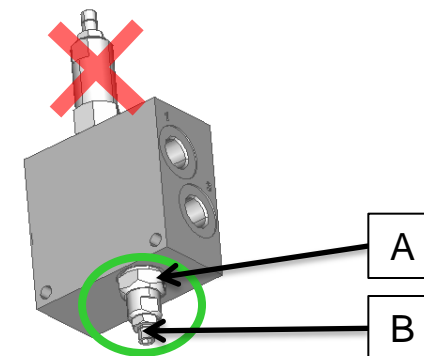
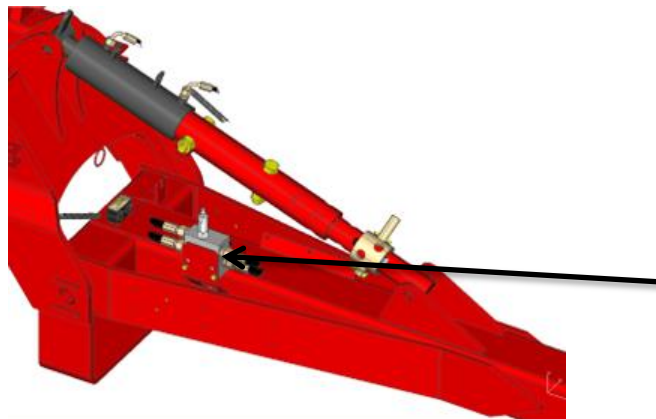
5.4 Parallel lifting



During lifting operations of the machine, if the latter rears too much, it is possible to make an adjustment. This adjustment is sensitive. Proceed in small steps (1/4 turn of the tap).

- Loosen the locknut (A).
- Rotate the limiter screw (B):
 - To raise the rear more rapidly: 
 - To raise the front more rapidly: 
- Once the adjustment is done, retighten the locknut.

5.5 Depth with parallelogram

Important, at work, the machine must always be horizontal.

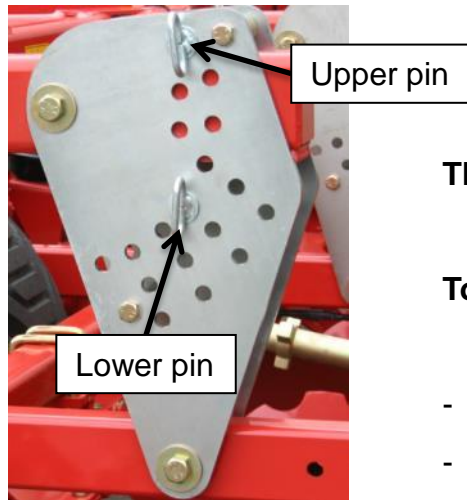

Parallelogram setting

The depth is controlled at the rear by the parallelogram.

To adjust the parallelogram:

- The lower pin determines the working depth
- It is possible to always have a pin above the arm to prevent movement headland turns
- Maintain accessory in up position allows a load transfer on the rear of the machine
- During transport it is recommended to remove the upper pins to allow accessory repositioning

5.6 Depth with double disc gang



With the double disc gang:

To set the stop valve in « A », proceed as follows:

- Raise the machine.
- Adjust the depth by positioning the hydraulic stop bar « A » on the corresponding hole.
- Lower the machine: the wagon will stop at the required depth.
- Try at work and correct according to the result. (The frame of the machine must be level to work).

5.7 Front wheels

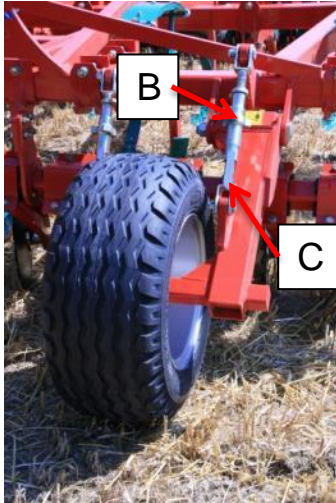

Front wheels:

- Lift the machine
- adjustment turnbuckle « B » by using the 27 spanner
- Adjust each wheel in the same way
- Check the length of the rod in « C ». This must not exceed 720 mm

5.8 FCD/FMD on CTC



Adjusting the pressure on the discs:

- Use the hydraulic cylinder
- To have a good cutting effect, recommended depth must be adjust from 3 to 8 cm

Compensation for disc wear:

- Remove bolts « A » and « B » located on each attachment
- Place the bolts on « B » and « C »
- Tighten the bolts

5.9 Levelling discs and levelling tines

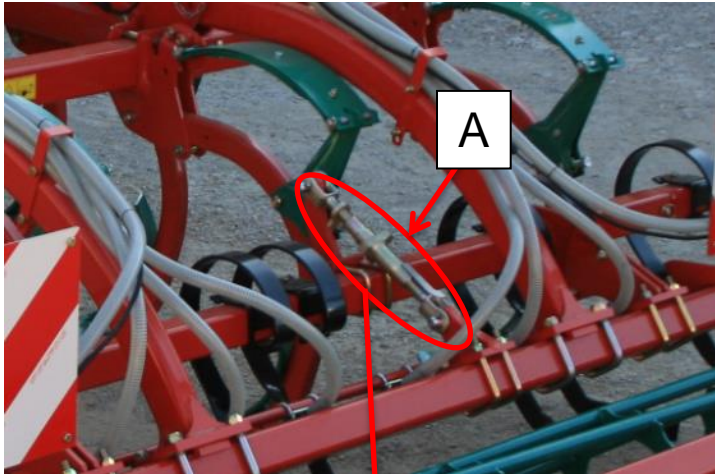

The levelling discs or levelling tines are centrally adjusted with adjusting rod (1 per section).

To adjust:

- Lift the machine
- Turn the adjustment rod in « A » using the 27 open-end spanner
- Adjust the discs or tines so that they touch the ground without penetrating it.
- Test and correct the adjustment depending on the quality of levelling achieved
- Too deep work can create ridge. Discs must work only on the notches area
→ 2-3 cm
- Check the distance between the rod axes. It must not exceed 520 mm

5.10 Combi disc

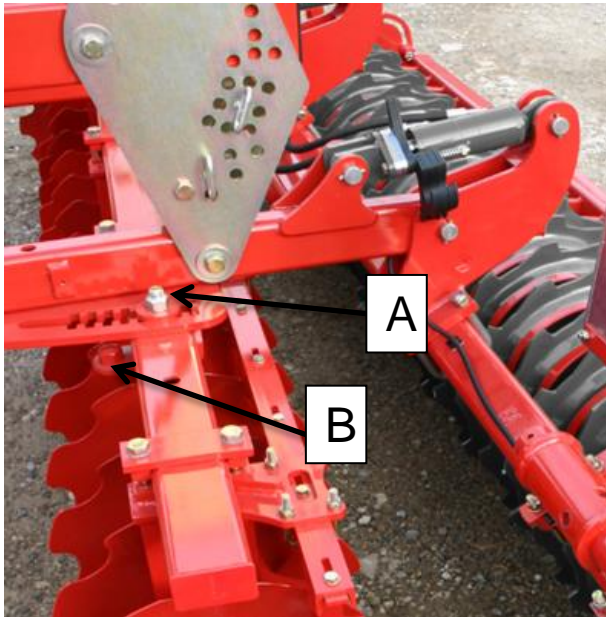

Depth setting on Combi disc:

- Lift the machine
- Open hydraulic cylinder
- Add or remove plastic spacers to adjust the working depth
- Adding spacers reduces the working depth
- Removing spacers increases the working depth
- Apply the same setting to all cylinders

Setting the angle of the combi-disc:

Some positions indicated on the setting plate might not be available depending of the accessories mounted on the machine

- Check if the angle is compatible with the machine configuration
- Unscrew the lock nut « A » using the spanner n°36 in order to release the indexing system
- Place the spanner n°36 on the handling assistance nut « B » and rotate the gang of the discs to the suitable angle
- Make sure that the indexing system is located at a predefined position and retighten the lock nut « A »

5.11 Lateral discs & tines

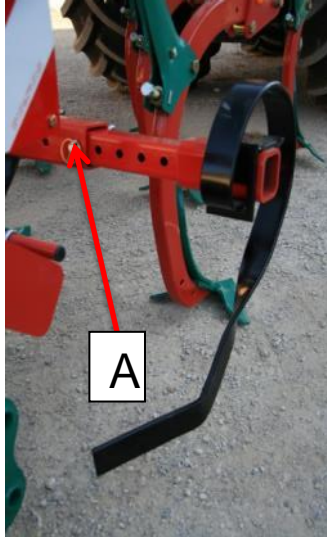

To adjust outside levelling tine and levelling disc :

- Remove the lateral adjustment spindle « A »
- Adjust the sideways position of the outside tines / discs
- Place the adjustment spindle
- Test and correct the adjustment if needed

To adjust border disc on Combi disc:

- Remove the spindle « B »
- Slide the border disc inside tube to adjust the distance of the edging disc with respect to the projection of the soil flow
- Place the spindle « B »

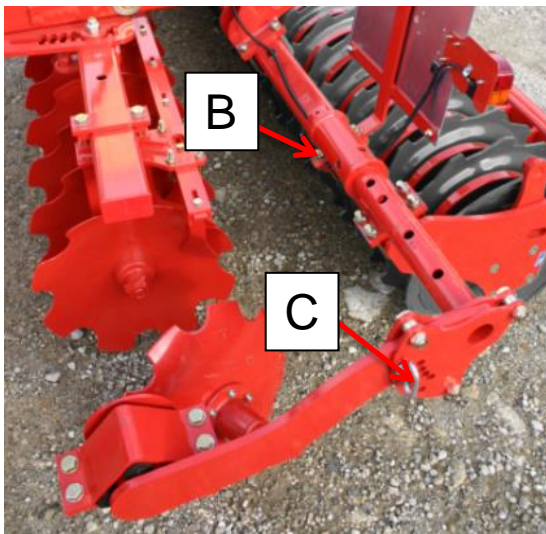

To adjust the height of the disc:

- Remove the spindle « C »
- Up or down the disc
- Engage the spindle « C » in one of the positions
 - Highest hole : high working depth of the Combi disc
 - Lowest hole : low working depth of the Combi disc
- Adjust the discs so that they touch the ground without penetrating it
- Test
- Adjustment is also directly link to working speed

5.12 Double disc gang



The method to set the angle of the double disc gang is the same than for the combi disc

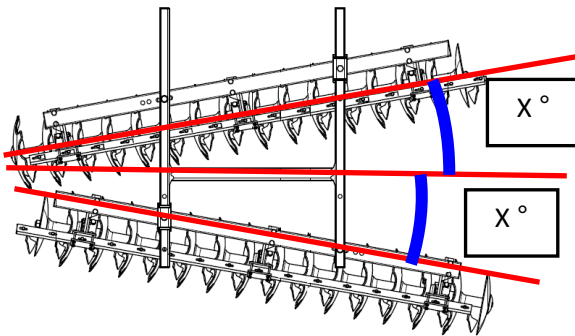

The working angle on double disc gang can be adjusted depending on the type of soil.

The angle should be set the same for both gangs (see drawing). In this way, the front gang is not more loaded than the rear.

5.13 Actipack/Actiring knives

For a finish levelled and crumbled / seedbed preparation:

- The height of knives must be adjusted in function of the ground, but also to the desired finish.
- Set the knives in position N° 1 (see drawing)
- Set working depth.
- Try the machine and check the work: if necessary increase pressure on knives (change position → N°2 or N°3).

Settings advice:

Light soil or sandy soil: knives raised (OFF)

Soil cloddy, clay: knives in the down position (1,2 or 3)

For a coarse finish / planting after winter or long period:

This surface condition can be requested if it is a work before winter or if the field should be left as is, subject to precipitation before seeding. So we want a coarser surface condition to avoid crusting. To do this, raise up the knives and put them in the OFF position (retracted).

To adjust the roller (see the pictures):

- Loosen the countersunk screw with the small wrench
- On the other side, insert the long Kv wrench in the welded nut to maintain the rear rail
- Loosen the countersunk screw
- Choose the position (1,2,3,Off) with the long Kv key
- Tighten the countersunk nut of the right and left side

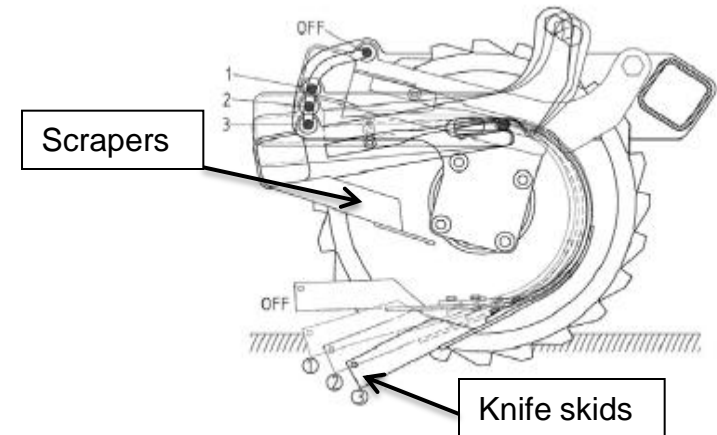

Position « 3 »



Position « Off »



Position « 1 »

5.14 Settings on Actiflex

For a finish levelled and crumbled / seedbed preparation:

We advise not to remove the levelling blades indicate in point A

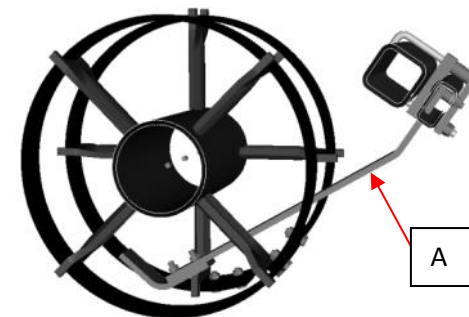

For a clod field before winter time:

We advise you to remove the levelling blades:

- Loosen nuts B on all U bolts (3 to 6 supports depending on the width)
- Remove levelling bar

To reset the levelling blades, apply the reversed procedure

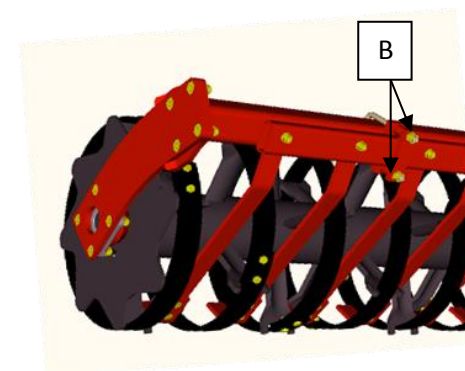
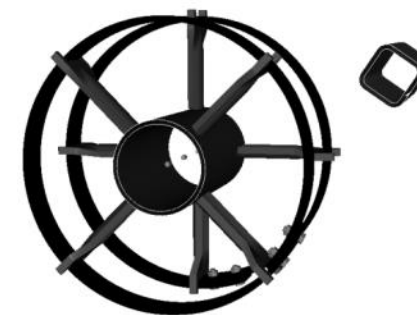

5.15 U-bolts on rollers

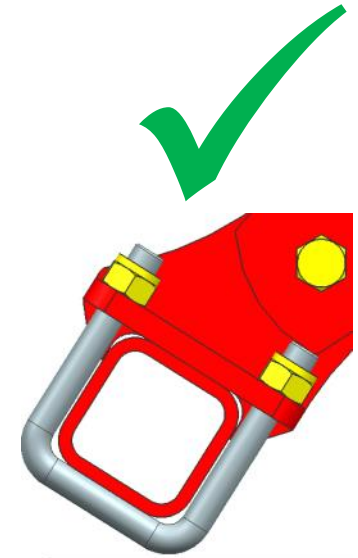
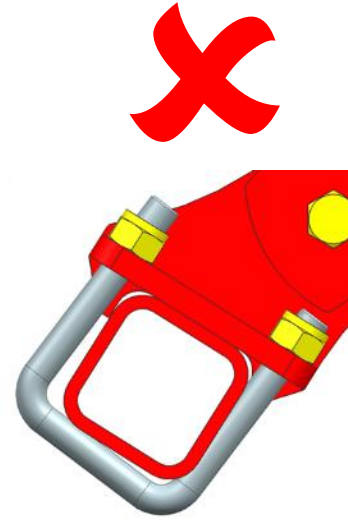
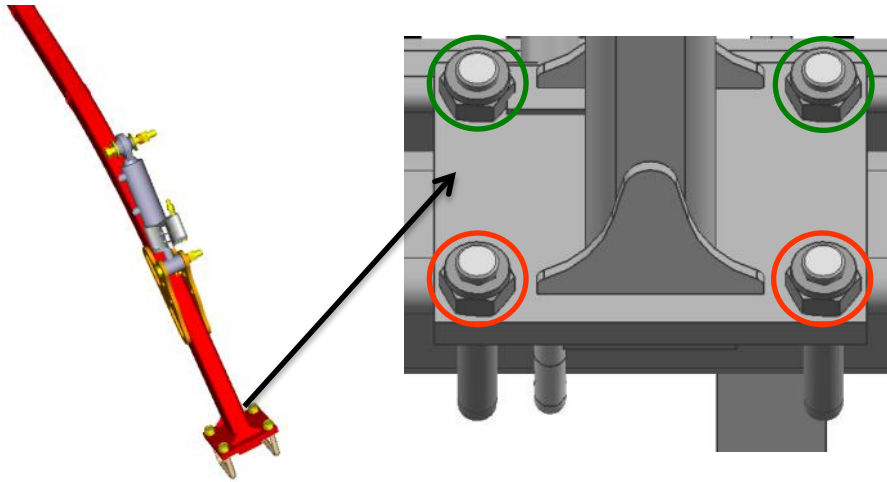

Tightening procedure:

- Screw green nuts in contact to plate
- Tighten red nuts to preconized torque → 667 N.m / 492 ft.lbf
- Tighten green nuts to preconized torque → 667 N.m / 492 ft.lbf

5.16 Tyres pressure

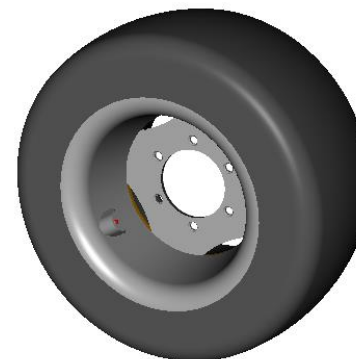

Tyre size	Pressure
400/60 - 15,5	3,6 bars (52 psi)
480/45 - 17	3 bars (44 psi)

Tyre size	Pressure
340/55-16	4 bars (58 psi)

Recommended torque gudgeon M18x150
→ 270 N.m (199 ft.lbf)

6.1 Greasing

This pictogram is placed next to all greasing points.



Drawbar + folding sides : Every 40 hours

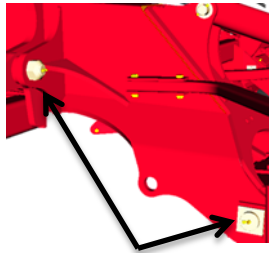

Disc : Every 40 hours



Front wheels : Once a years



Disc gang : Every 40 hours



Wagon : Every 20 hours

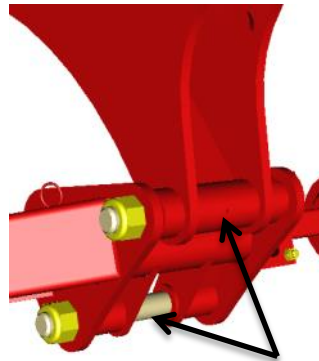

Transport wheels : Once a years

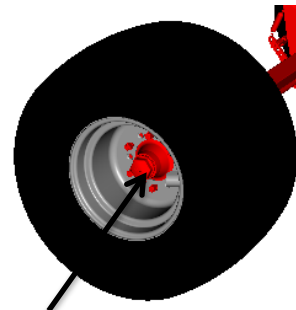

Linkage : Every 20 hours

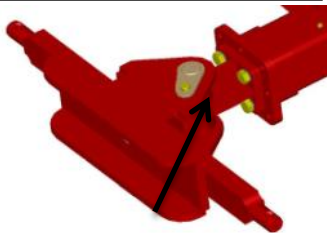

Double cage rollers : once a day



6.2 Wearing parts on tines

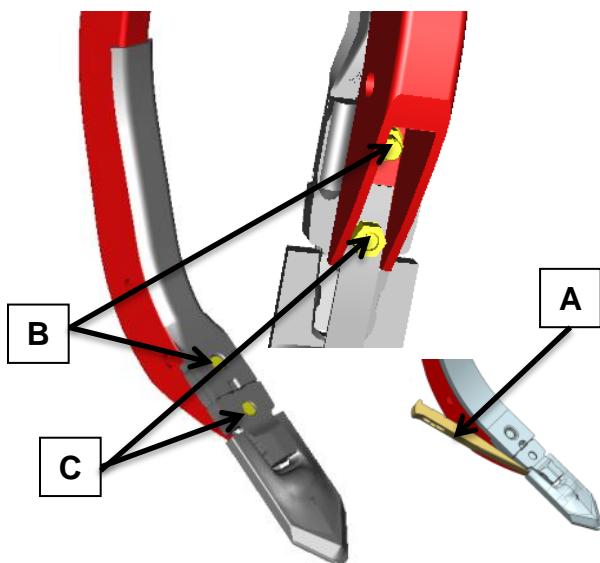

Knock-on replacement:

Share:

- Remove the share with the tool and an hammer. See the position of the tool in « A »

Deflector:

- Remove the bolt in « B »
- Change the deflector
- Replace the bolt
- Tighten the bolt

Holder:

- Remove bolts « B » and « C »
- Change the holder
- Replace the bolt
- Tighten the bolt

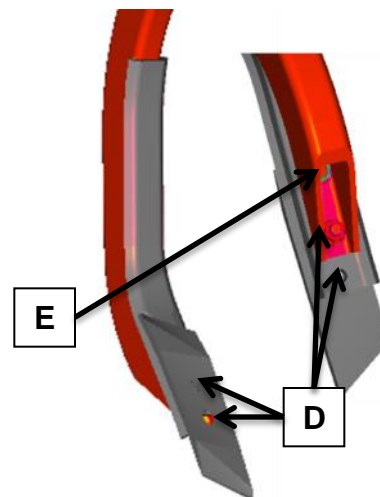

Plough point/deflector replacement:

Share:

- Remove bolts in « D »
- Change the share
- Replace bolts
- Tighten bolts

Deflector:

- Remove bolt in « D » and « E »
- Change the deflector
- Replace bolts
- Tighten bolts

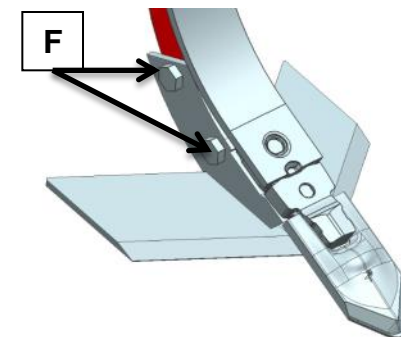

Quantum replacement:

- Remove bolts in « F »
- Change the Quantum
- Replace bolts
- Tighten bolts

6.3 Wearing parts on accessories

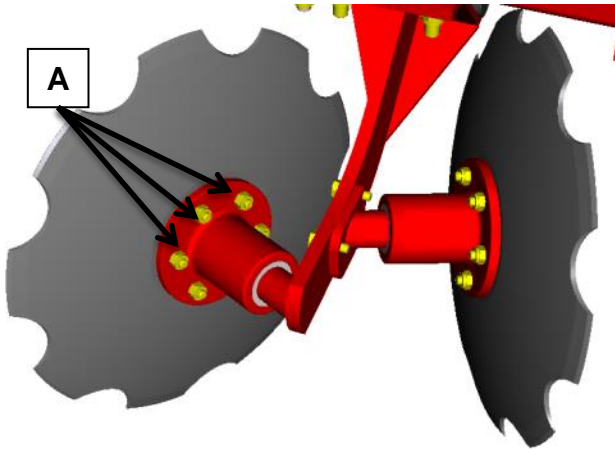

Disc of hollow disc replacement:

- Remove bolts « A »
- Change the disc
- Replace bolts
- Tighten bolts

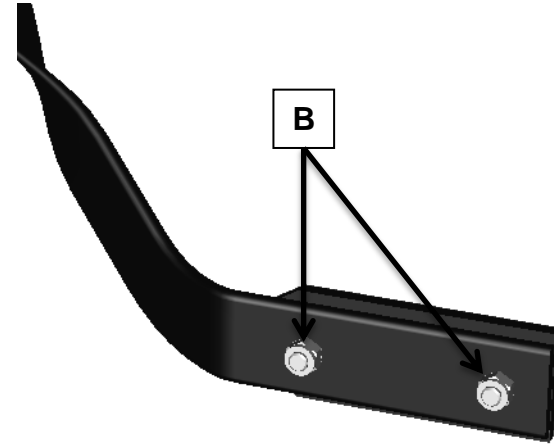

Extension of levelling tine replacement:

- Remove bolts « B »
- Change the extension
- Replace bolts
- Tighten bolts

6.4 Wearing parts on rollers

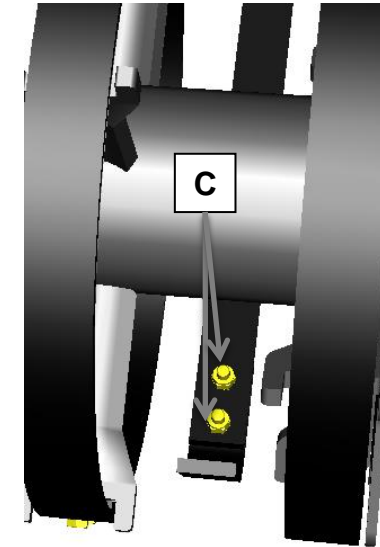
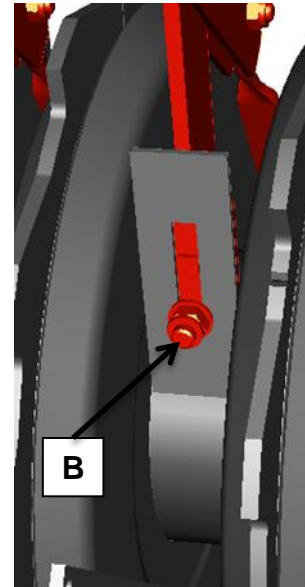
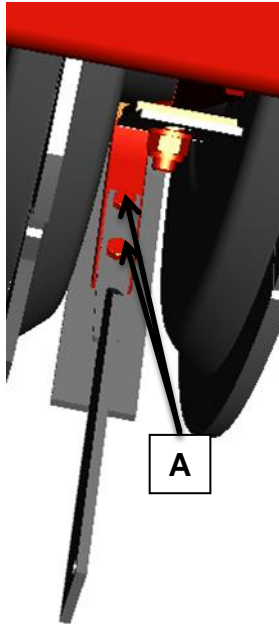

Skid on Actiring/Actipack replacement:

- Remove bolts « A »
- Change the skid
- Replace bolts
- Tighten bolts

Scrapper on Actipack replacement:

- Remove the bolt « B »
- Change the scrapper
- Replace the bolt
- Tighten the bolt

Wearing part on Actiflex replacement:

- Remove bolts « C »
- Change the wearing part
- Replace bolts
- Tighten bolts

6.5 Wearing bush

Wearing bush : replace bushes if significant play appears on a ringed articulation

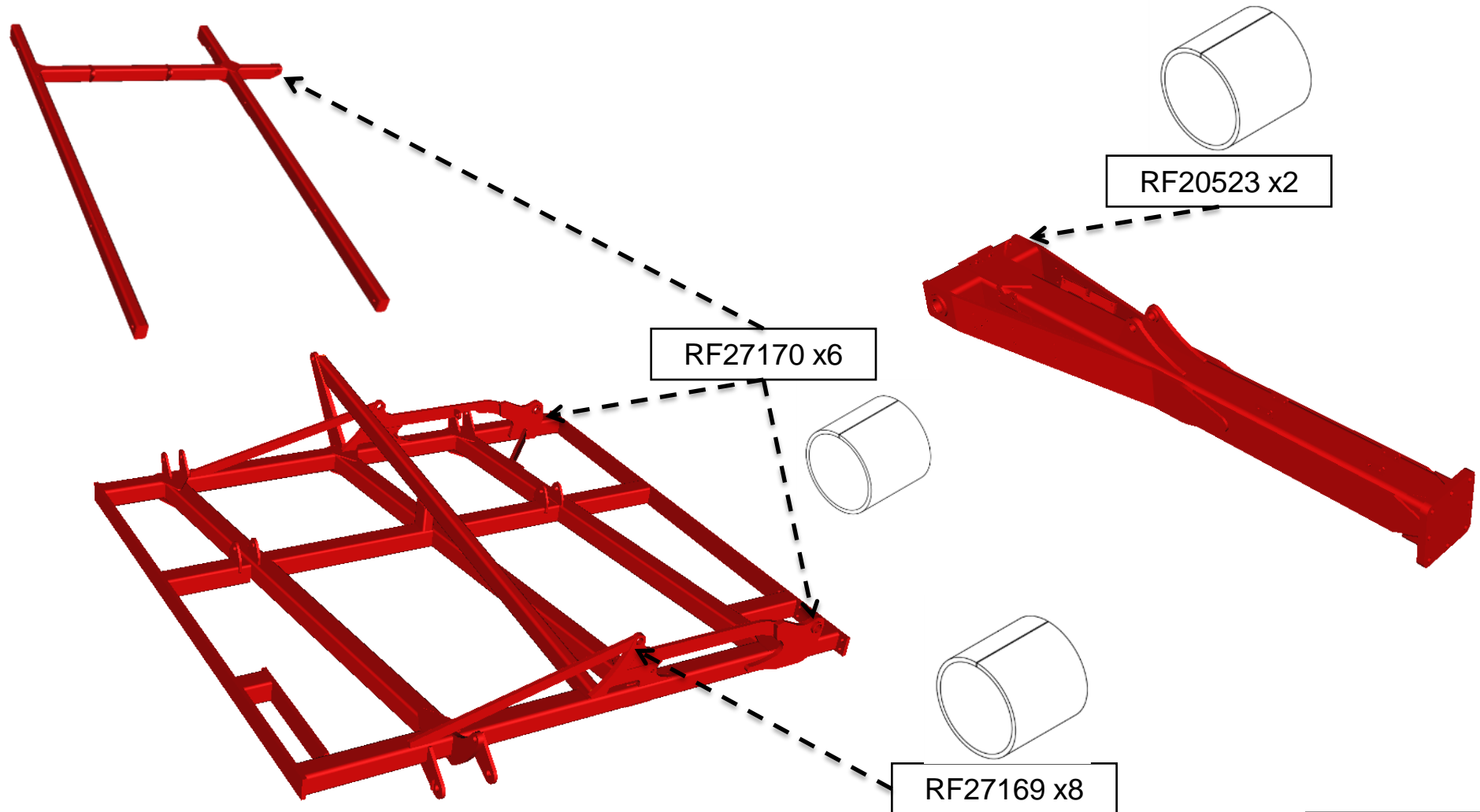

6.6 Depth cylinders

For the depth cylinders :

The kit A or B can be originally installed on the cylinder and can be delivered by Spare Parts under the same part number. Main difference is on piston seals.



RF2986486



RF3182686

Hydraulic



	Kit "A"	Kit "B"
Overview from piston		
Number of seals in total	9	10
Seals used for piston	4	5

7. Hydraulic diagrams

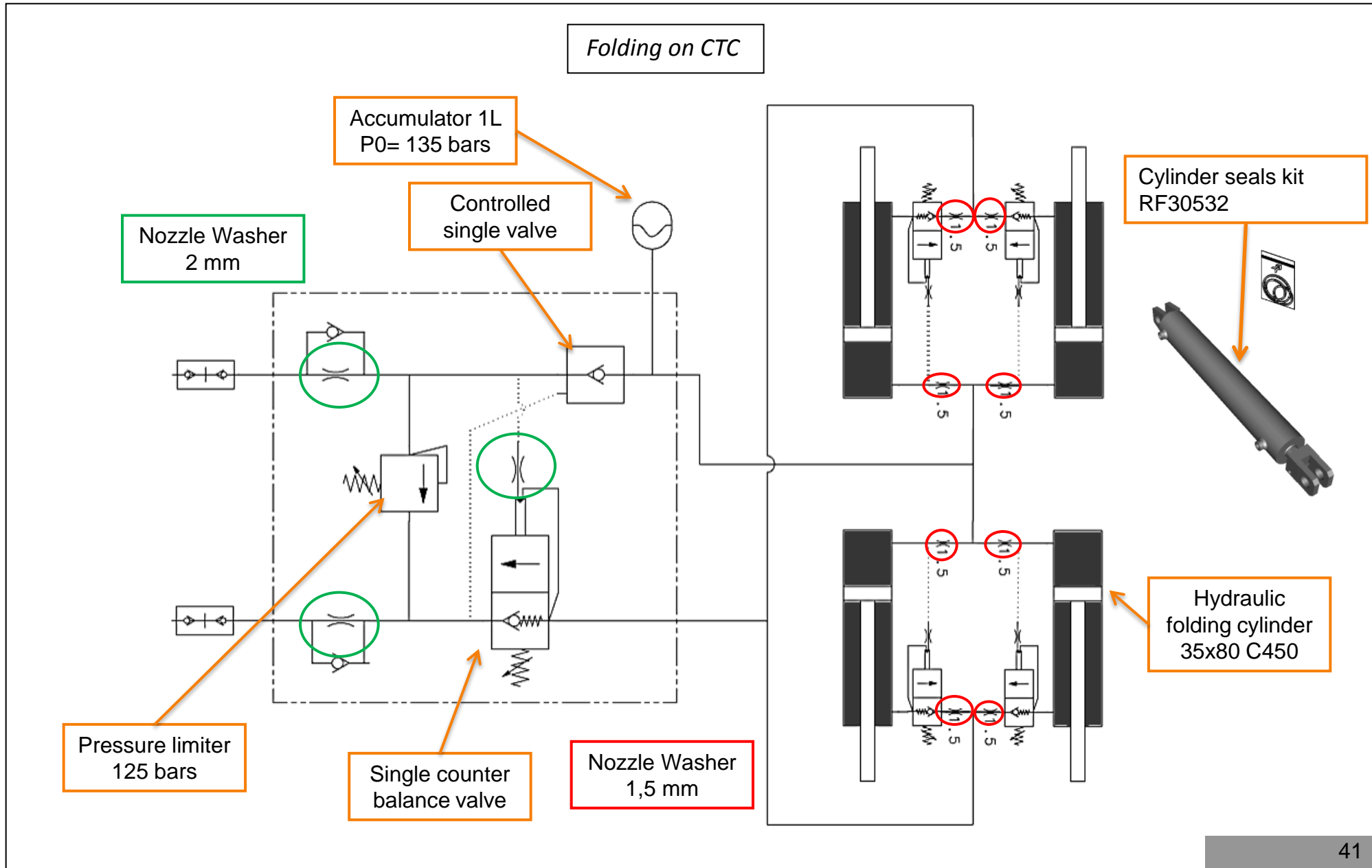

Depth setting of combi-disc

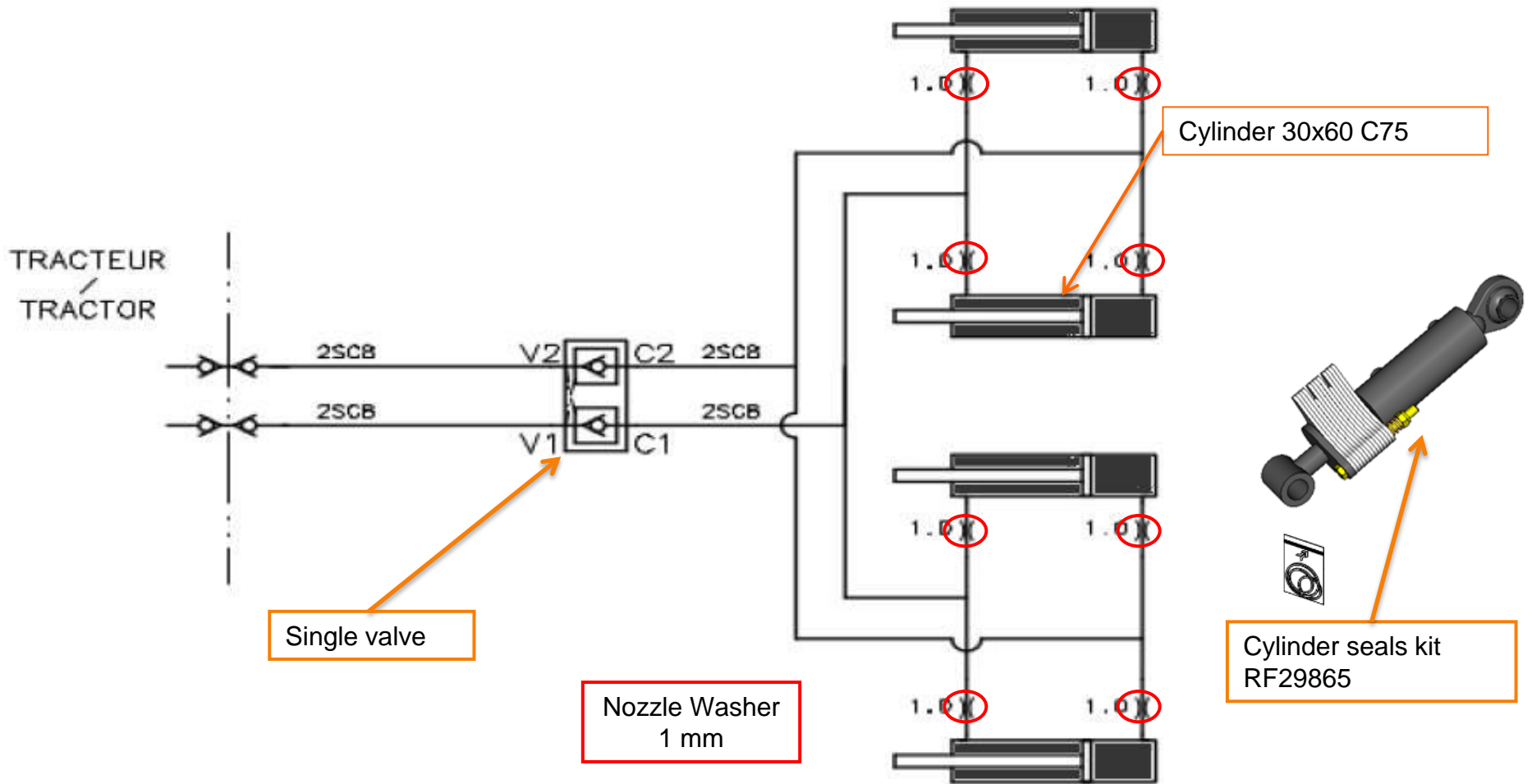

Depth setting of combi-disc with 2 function electrovalve

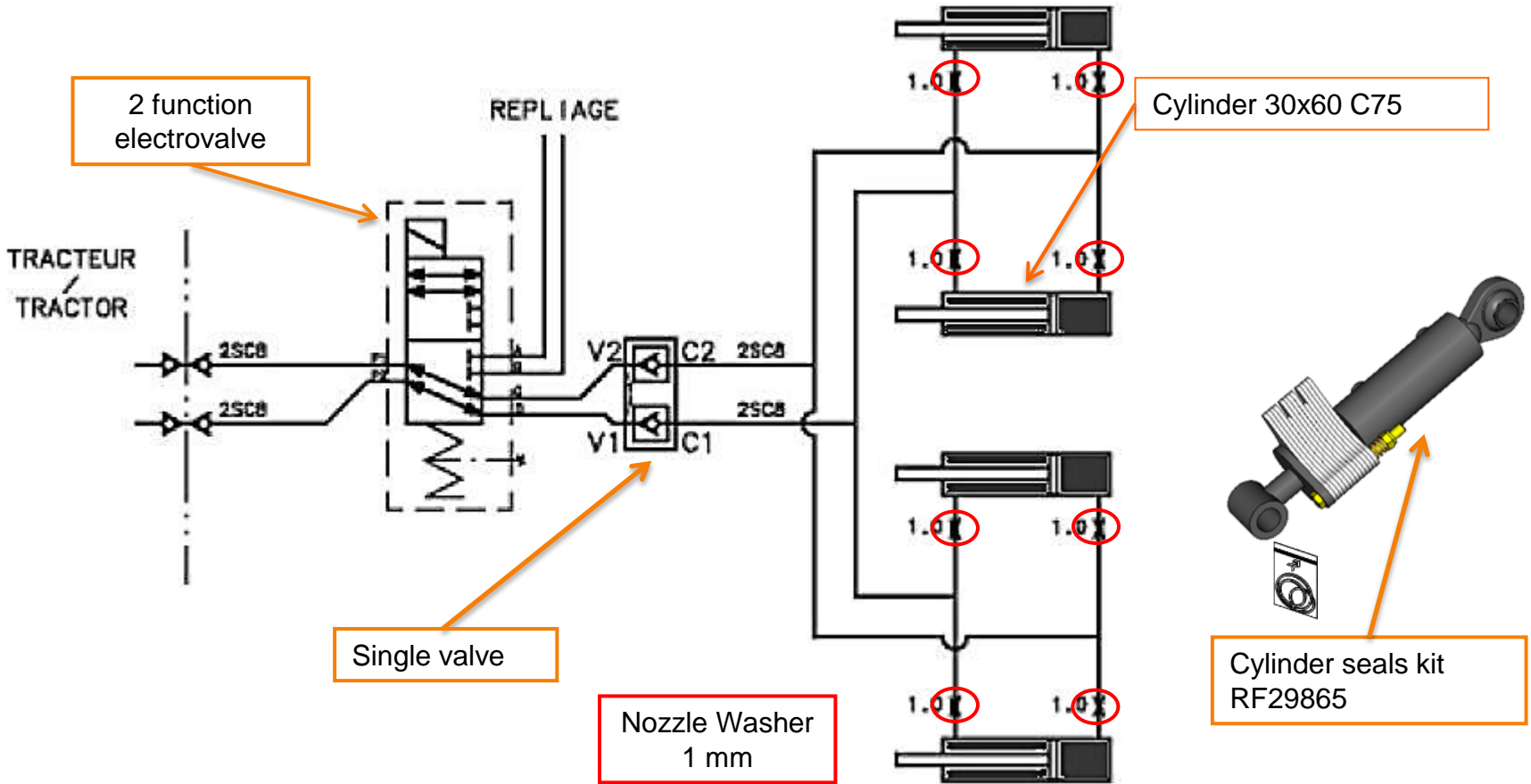

Lifting on CTC

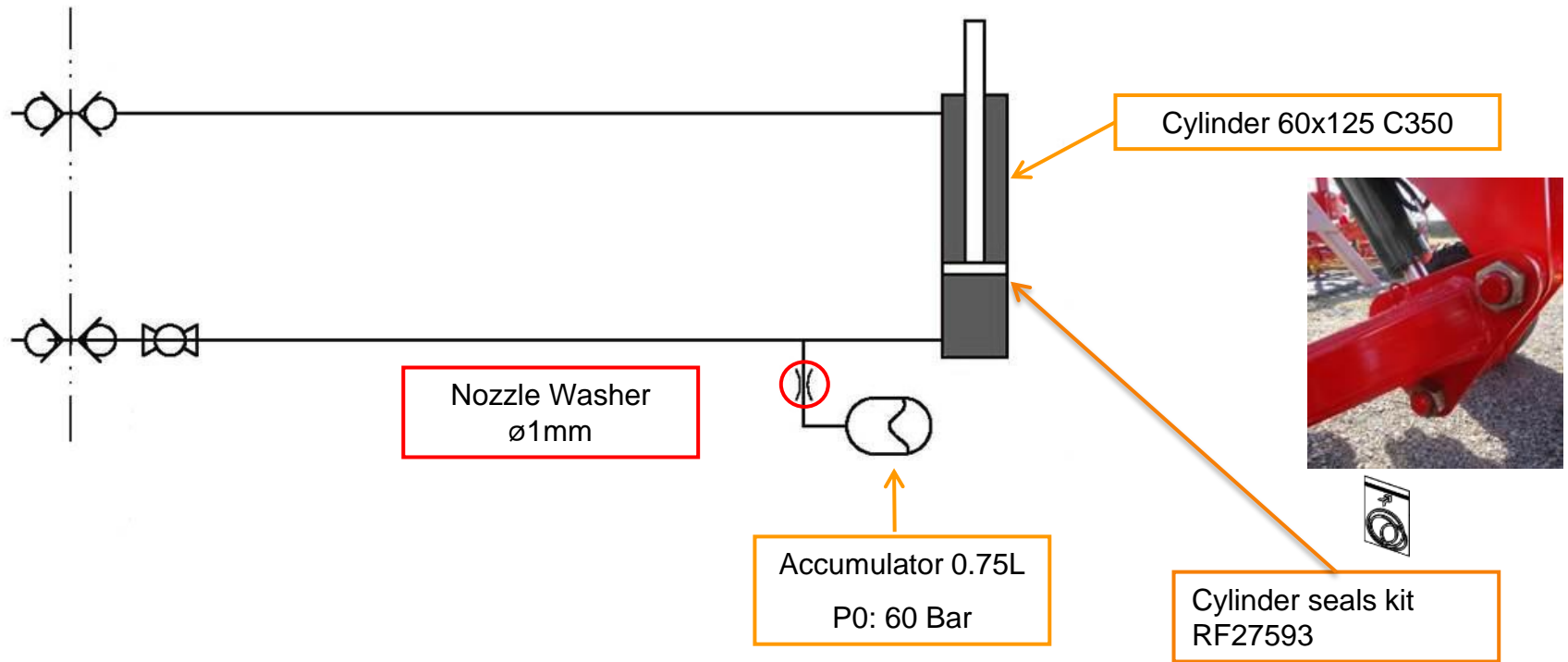

7. Hydraulic diagrams

