

A-915-01

## Rebuild of Cutterbar

[B-Hub only]

Date printed	01.2019
Language	EN
Kit number	-
Document number	A-915
Index	2018-01

Brand:

**Kverneland**

**Vicon**

**Kubota**

**Deutz-Fahr**

Model:

All Models

All Models

All Models

All Models

Subject:

**Rebuild of Cutterbars (B-Hub only)**

Kverneland Group Kerteminde AS  
Taarupstrandvej 25  
DK-5300 Kerteminde - Denmark  
Tel./fax: +45 65 19 19 00 / +45 65 19 19 99  
web: [www.kvernelandgroup.com](http://www.kvernelandgroup.com)

# Tool Kit

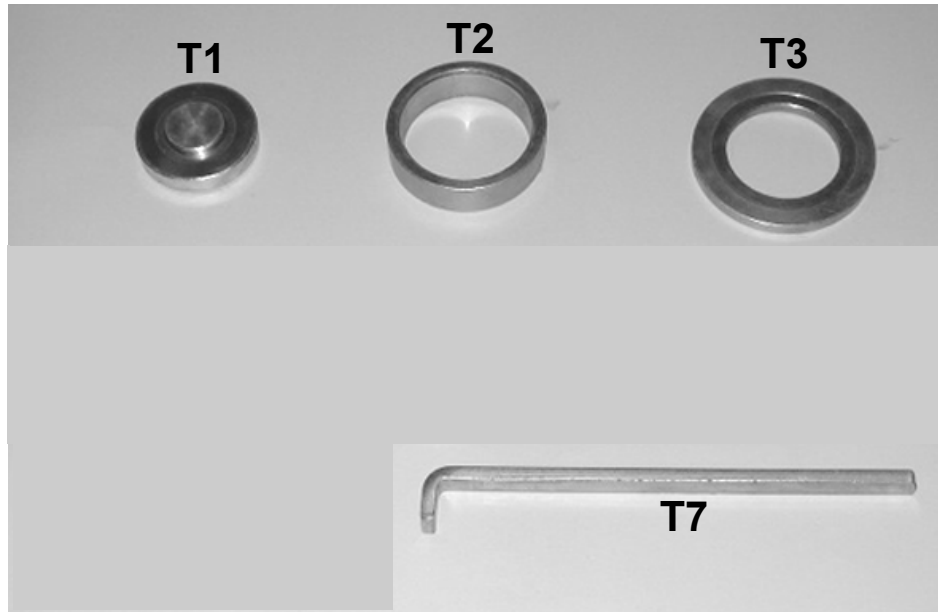

Tool	Description
T1	Tools with pin for centering for disassembly / assembly of bearing in the bearing unit.
T2	Tool with a conical hole for removal/fitting of bearing in the intermediate gear wheels.
T3	Tool equipped with support and centering for fitting of bearing in the intermediate gear wheels Tool equipped with support and centering for fitting of bearing in the gear wheels (used in combination with tool T2).
T7	Tool for removal/fitting of special nut on the cutterbar.

## Drainage of oil

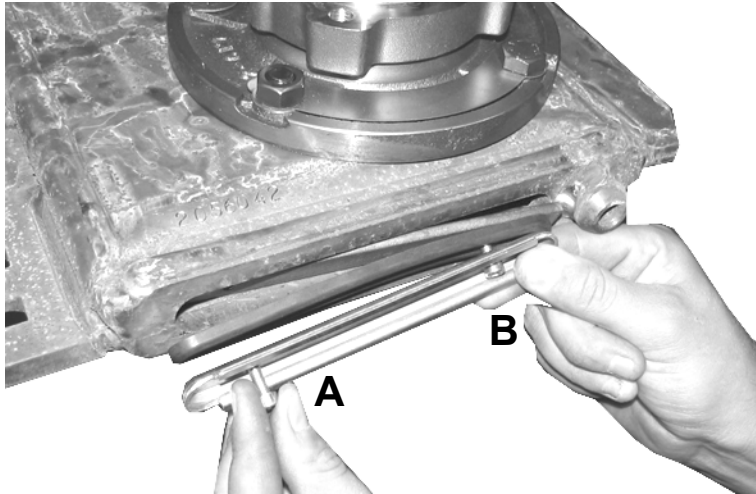

- ▶ Place a suitable receptacle below the end of the cutterbar.
- ▶ Remove screw "A"
- ▶ Loosen screw "B" a bit.
- ▶ Remove both the end cap and the gasket.

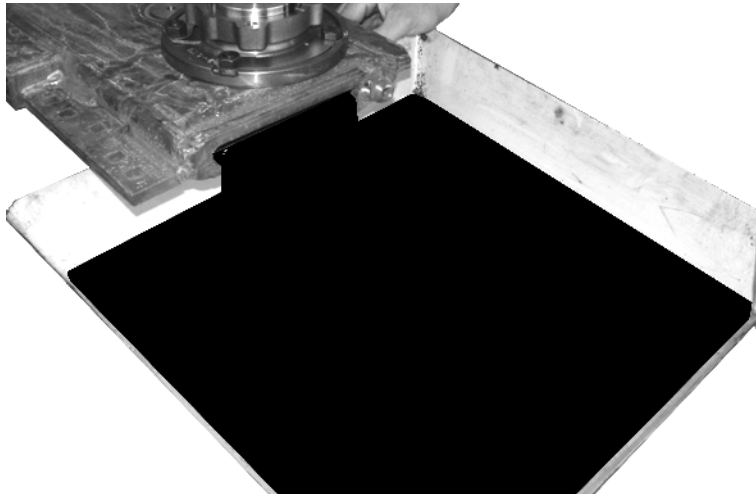

- ▶ Let the oil to run into the receptacle.
- ▶ Let the last of the oil drip of the cutterbar for approx. 10 - 15 minutes.

## Removal of bearing units

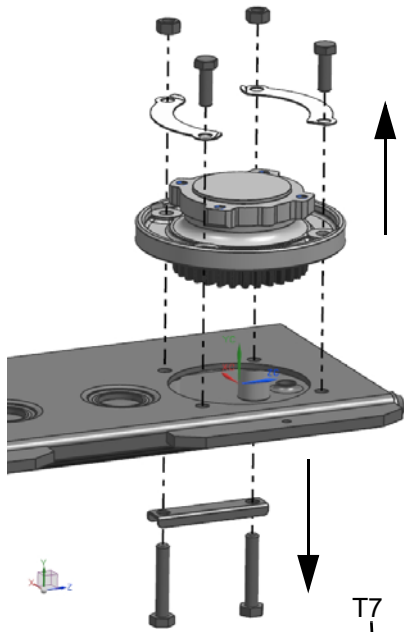

- ▶ Remove the bolts and nuts shown.
- ▶ Remove the lock plates shown.
- ▶ Remove the bearing unit from the cutterbar.

**i** **NB!** The bearing unit can be removed from the cutterbar without the oil is drained. the inspection of the intermediate gear wheel can be done by carry out the inspection through the hole of the bearing unit in the cutterbar.



- ▶ Use tool T7 as shown and force the edge of the plate up a bit.
- ▶ Remove all the special nuts in the cutterbar.

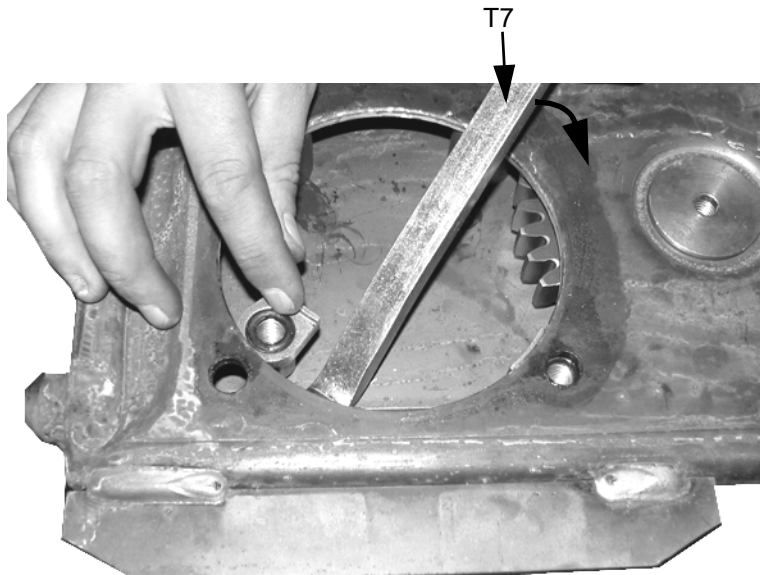

- ▶ Use tool T7 as shown and force the edge of the plate up a bit.
- ▶ Remove the bushings for the bolts.

**i** **NB!** The through bolts is only used in the outer bearing units in both ends of the cutterbar.

## Removal of intermediate wheels

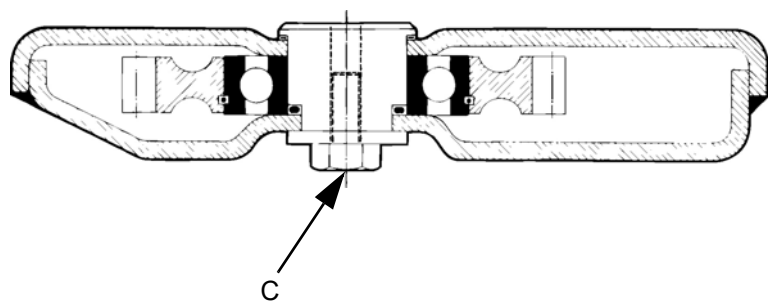
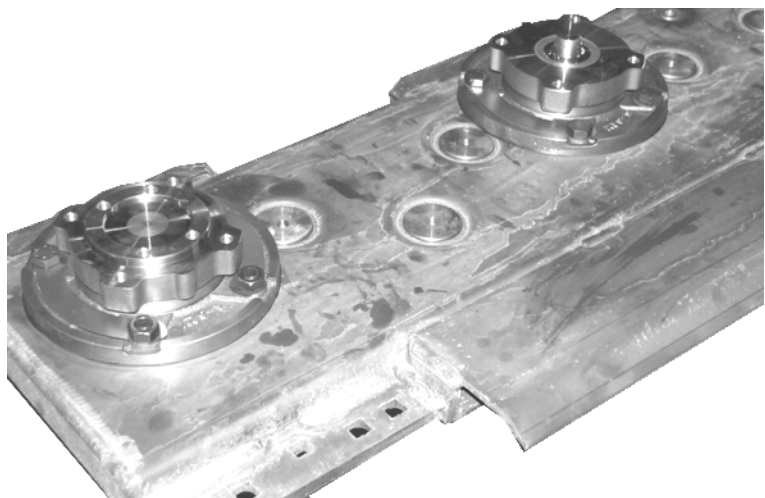

- ▶ Remove bolt "C" from the cutterbar as shown.

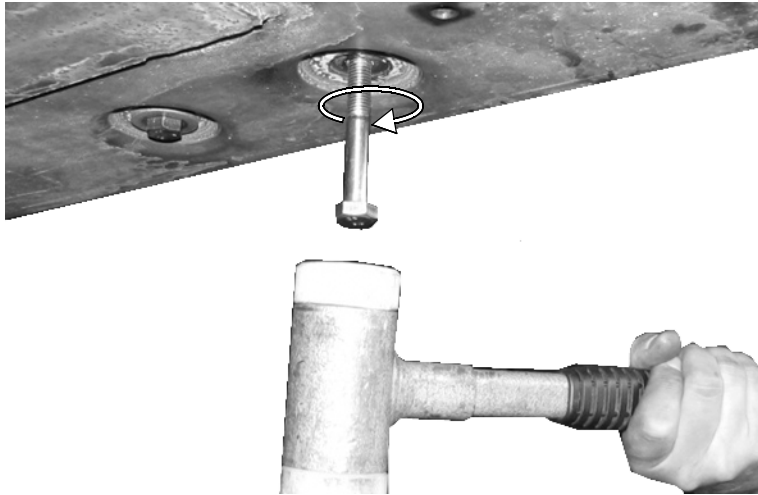

- ▶ Use a longer bolt of the same size and screw the bolt in the shaft.
- ▶ Force the shaft out of the cutterbar by use of a hammer.

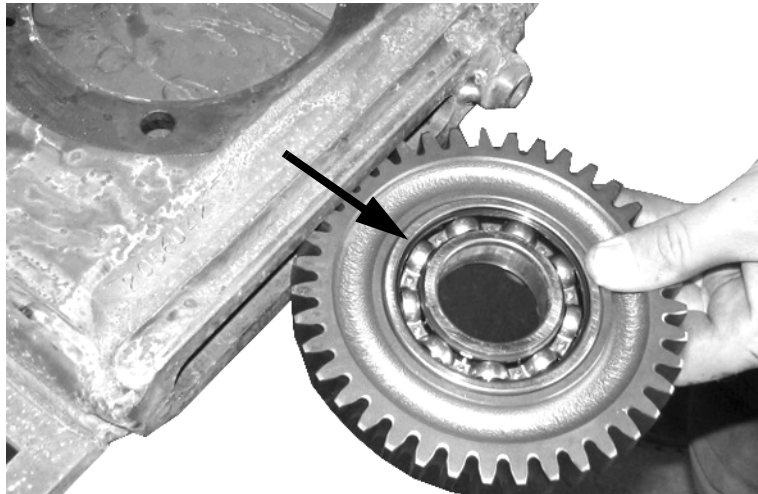

- ▶ Guide the intermediate gear wheel out through the gap in the end of the cutterbar.

## Cleaning of Cutterbar

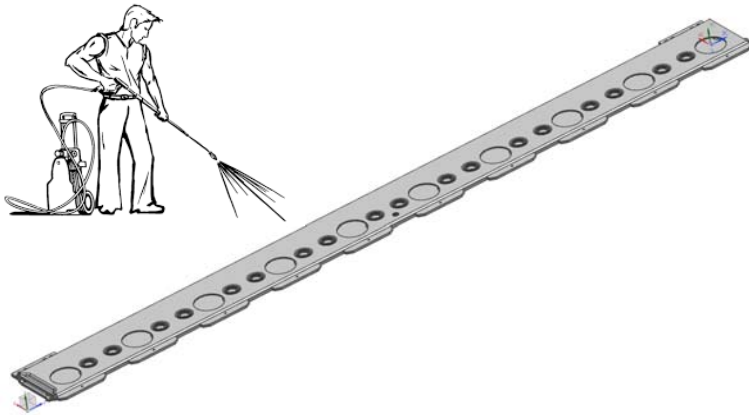

- ▶ Clean the cutterbar housing thoroughly by use of a high pressure cleaner.
- ▶ Make sure the housing is completely clean of any kind of metal chips and metal pieces.

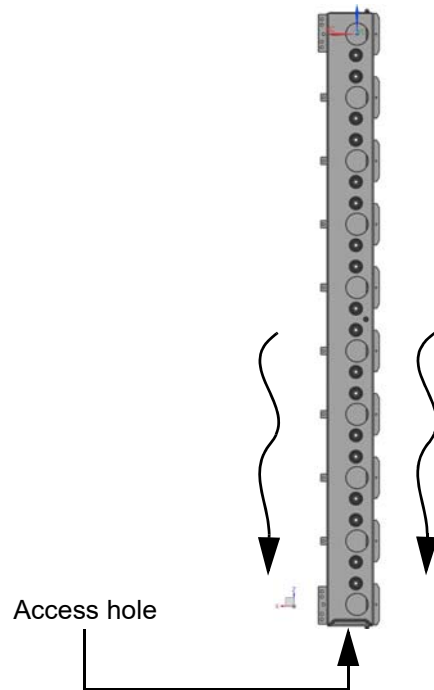

- ▶ Let the cutterbar housing dry for couple of hours.
- ➡ it is recommended to hang the cutterbar housing in a vertical position with the access hole at the bottom for drainage.

# Rebuild of intermediate wheels

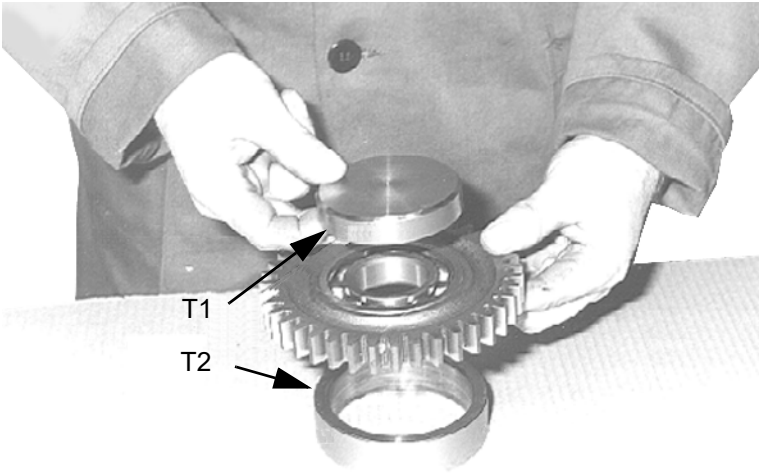

▶ Place the intermediate gear wheel on top of tool T2.

**i** **NB!** The largest diameter of the tool has to be faced upwards. Place tool T1 on top of the bearing as shown.

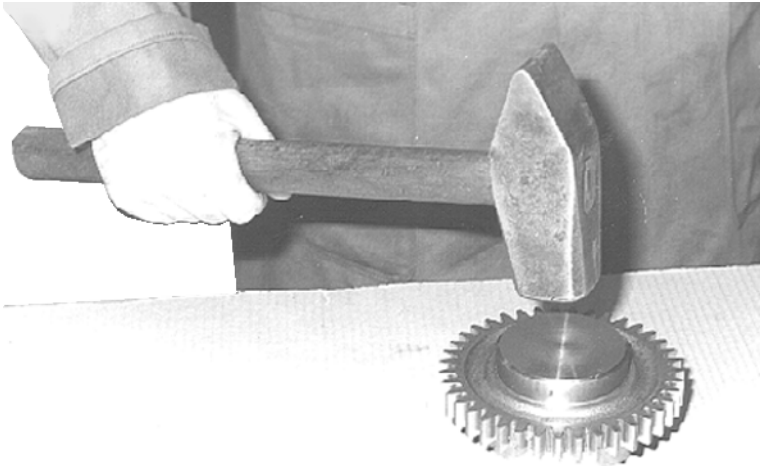

▶ Force the bearing out of the gear wheel by use of a hammer.

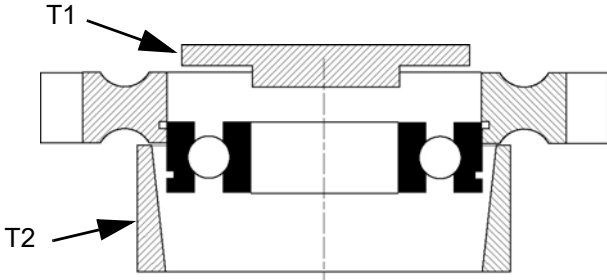

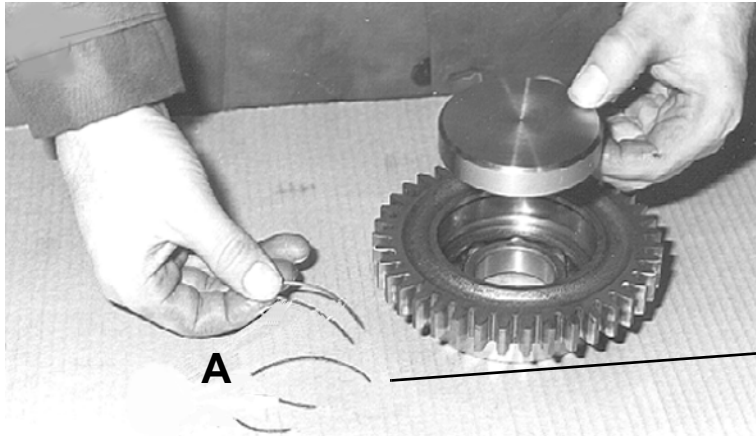

▶ Remove tool T1 from the gear wheel and remove all the broken parts (typically 5 pieces) of the circlip "A"

**i** **NB!** Make sure that all the broken parts from the circlip is removed from the intermediate gear wheel.

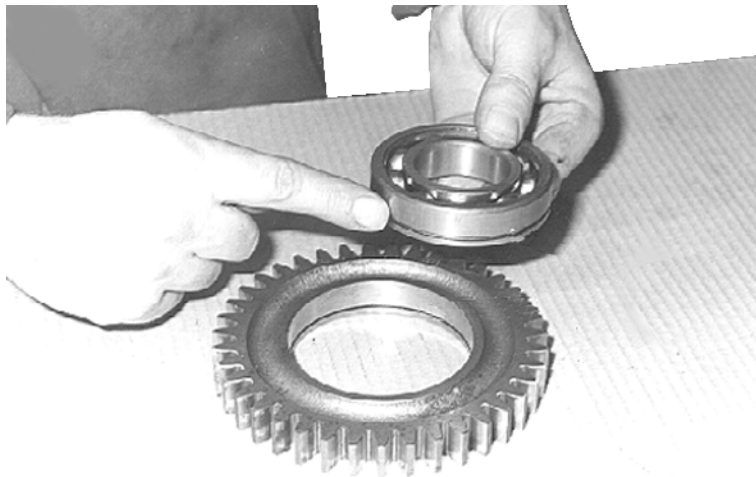
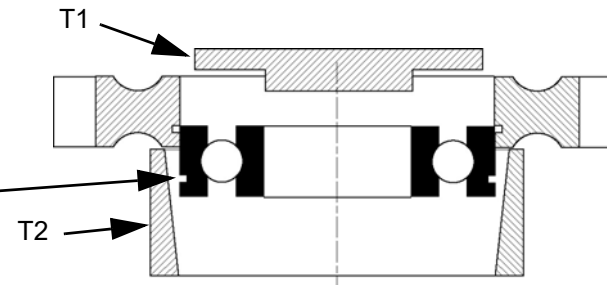

▶ Make sure the gear wheel and the new bearing is facing the right way.

**i** **NB!** The groove in the bearing and in the gear wheel has be faced downward.

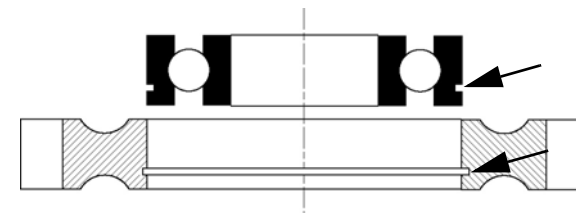

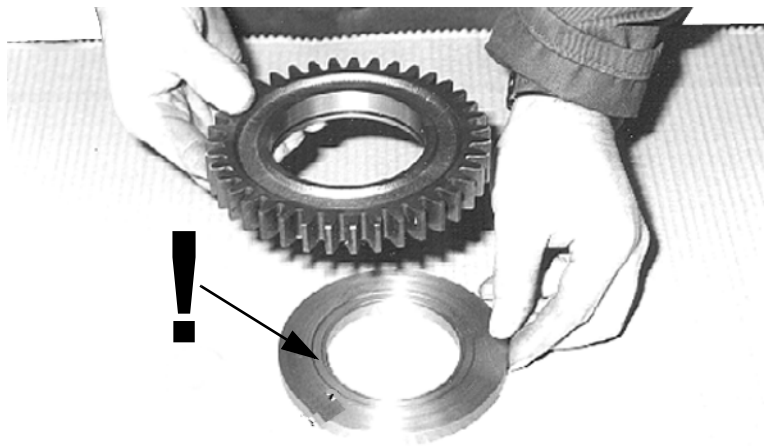

▶ Place the gear wheel on top of tool T3.



**NB!** The recessed surface has to be faced upwards.

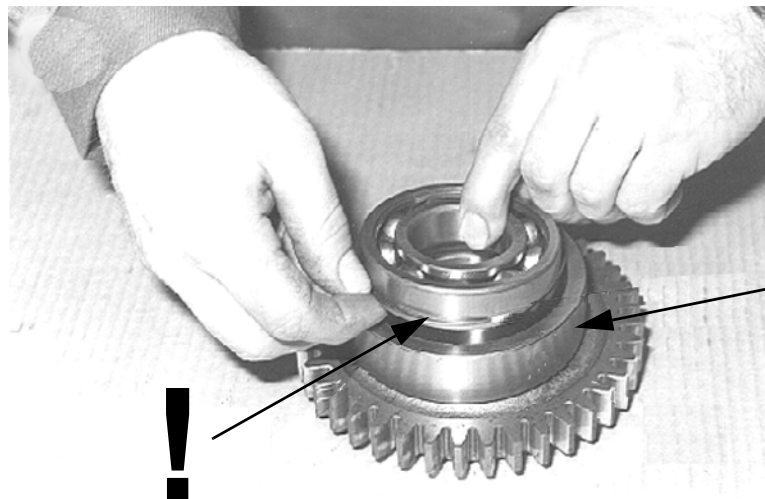

▶ Place tool T2 on top of the gear wheel as shown.



**NB!** The largest diameter of the tool has to be faced upwards.

▶ Place the new circlip in the groove on the bearing.

▶ Place the bearing in the cone shaped tool T2.

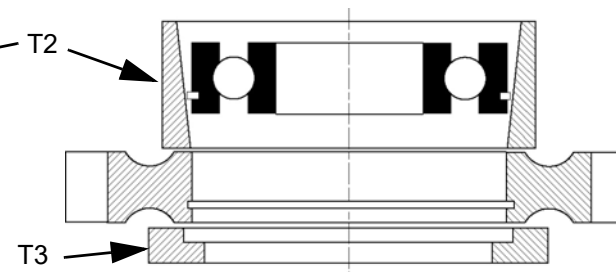

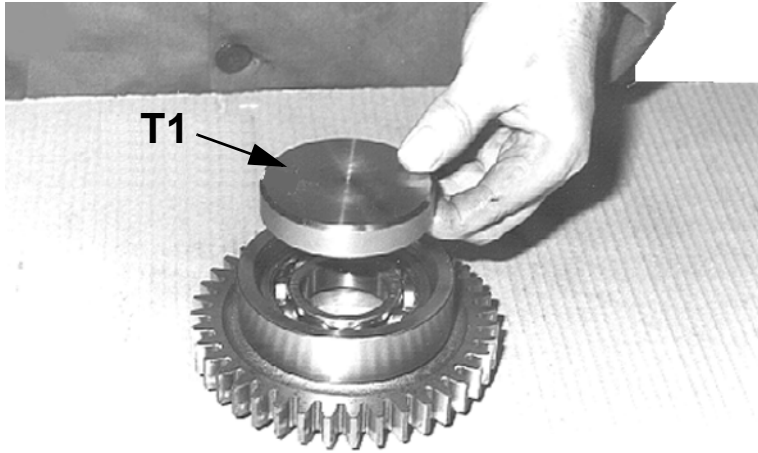

► Place tool T1 on top of the bearing as shown.

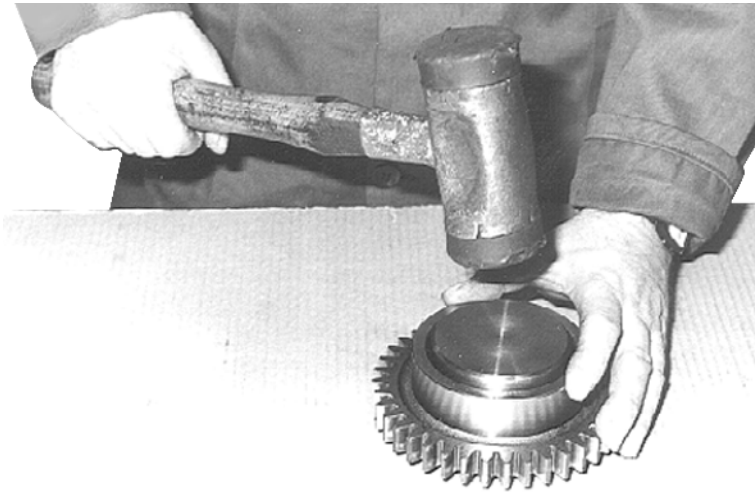

► Force the bearing in place by use of a hammer as shown.



**NB!** The bearing must at all times being forced by the tool on the outer ring of the bearing when it is placed in the bearing house.

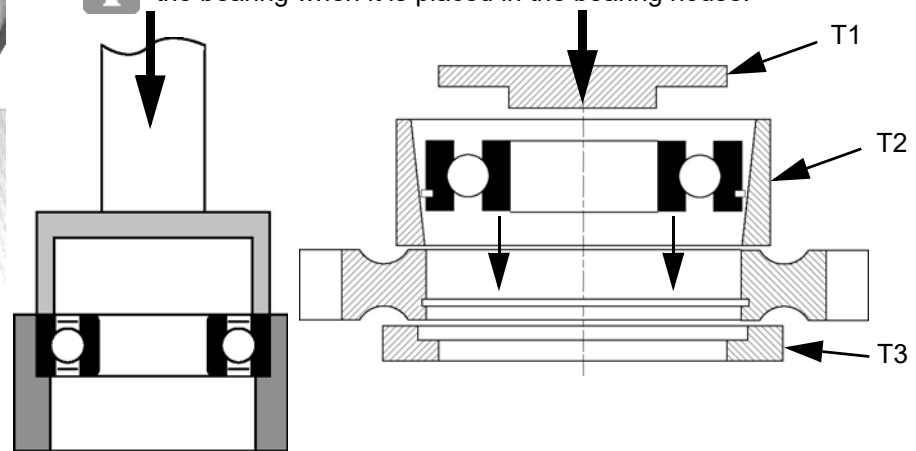

## Fitting of intermediate wheels



- ▶ Make sure the bearing is locked and fixed by the circlip
- i** **NB!** Force the bearing backward and forward a bit to check the bearing is locked and fixed in the gear wheel.

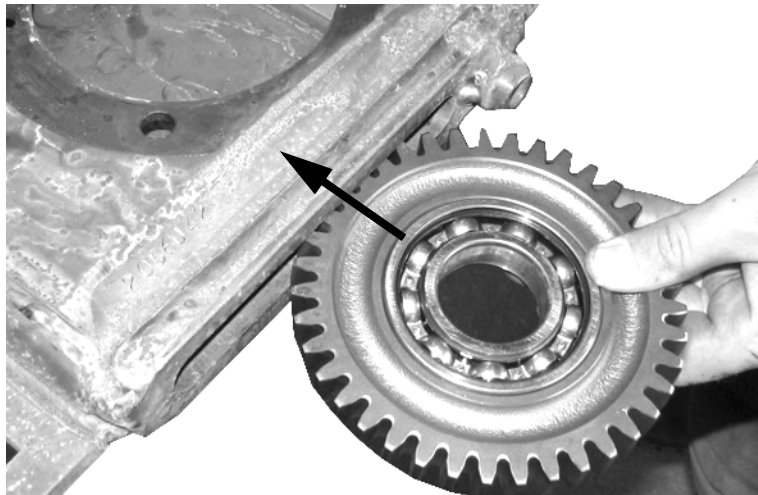
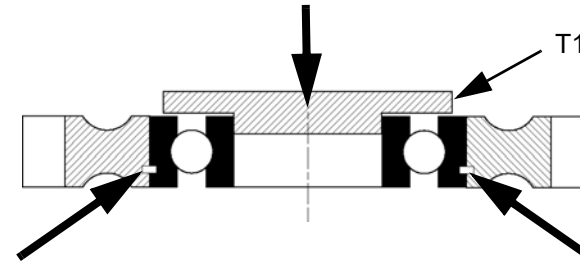

- ▶ Guide the gear wheel through the gap in the cutterbar.

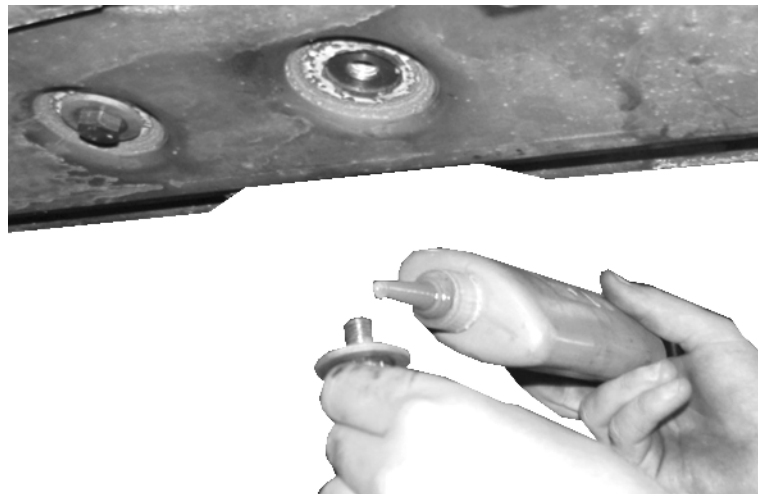
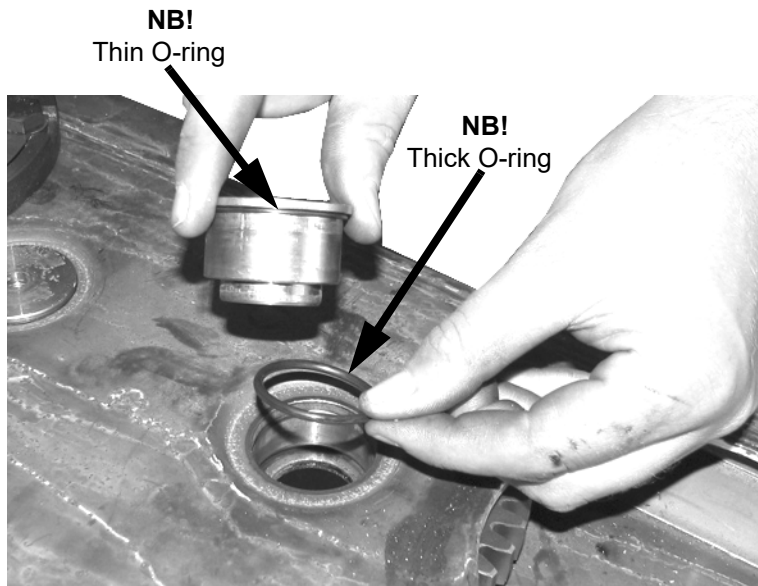

- ▶ Fit new O-rings on the shafts and into the hole for the shafts.
  - i** **NB!** Always use new O-rings before fitting of the shafts.
  - ▶ Fit the intermediate gear wheel.
  - ▶ Place and carefully force the shafts through the gear wheels.
  - i** **NB!** Make sure the gear wheels is placed just under the hole for the shafts in the cutterbar when fitted.
- 
- ▶ Provide the lock bolt with LOCTITE 242 or similar product when fitted in the shaft.

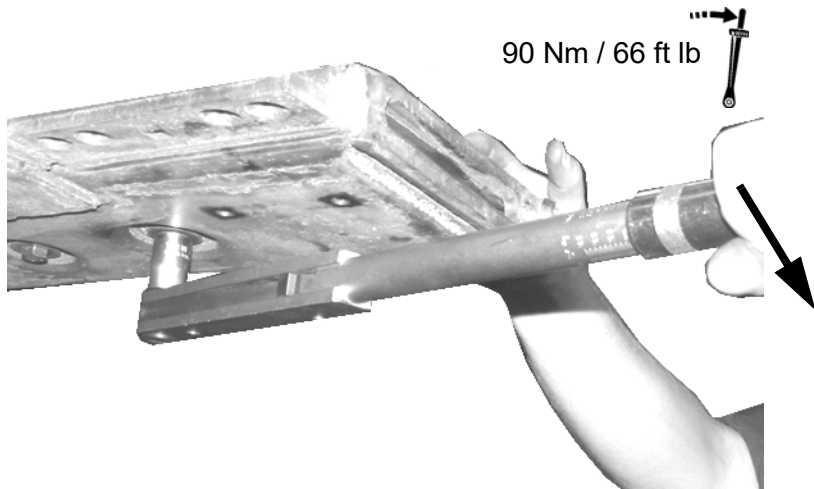

- ▶ Tighten the lock bolts to 90 Nm / 66 ft.lb. by use of a torque wrench.

# Fitting of Bearing Units

The 2 outer Bearing Units only

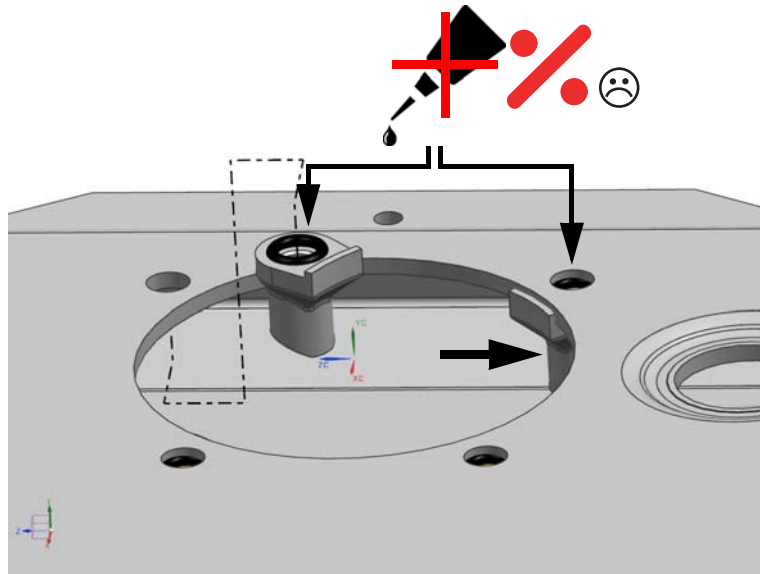

All the special nuts are provided with new O-rings.

▶ Carefully place all the special nuts in the cutterbar as shown.

▶ Do not add any sealing on the special nuts.



**NB!** Do not damage the O-rings when the special nut is placed in the cutterbar.

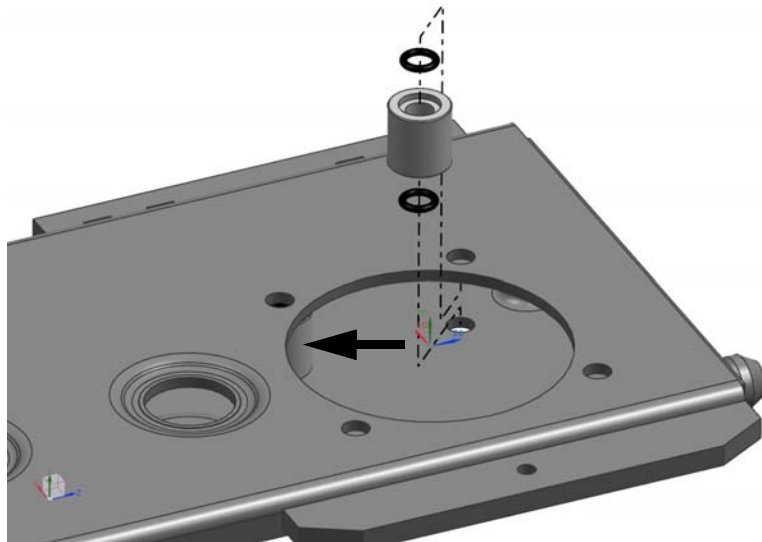

All the special nuts are provided with new O-rings.

▶ Place the bushings for the bolts.



**NB!** Do not damage the O-rings when the special nut is placed in the cutterbar.

## Remaining Bearing Units

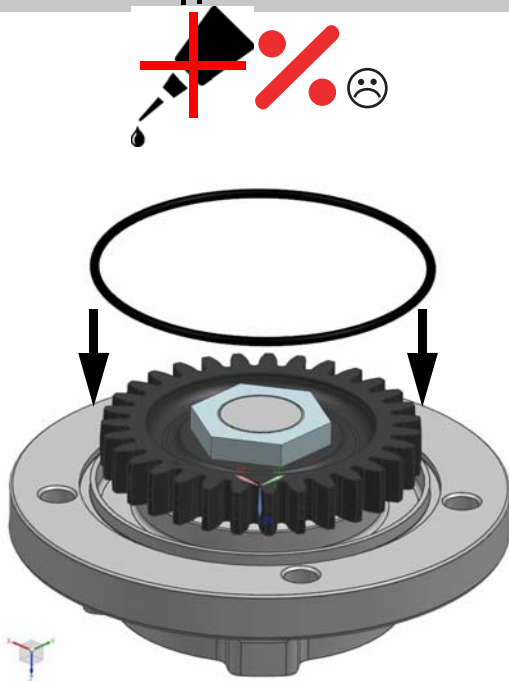
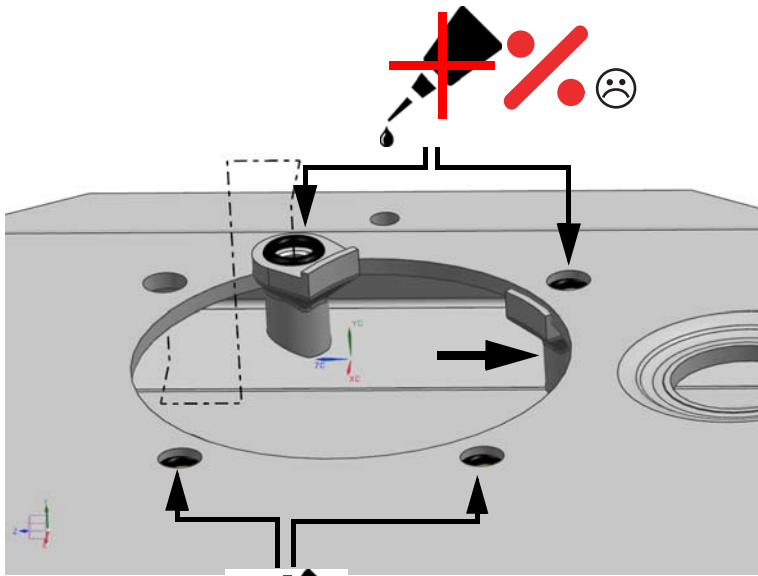

All the special nuts is provided with new O-rings.

▶ Carefully place all the special nuts in the cutterbar as shown.

▶ Do not add any sealing on the special nuts.



**NB!** Do not damage the O-rings when the special nuts is placed in the cutterbar.

▶ Fit the O-ring on the Bearing units as shown.

Permalock AN 5542  
Loctite 542  
Cyperbond SM 40

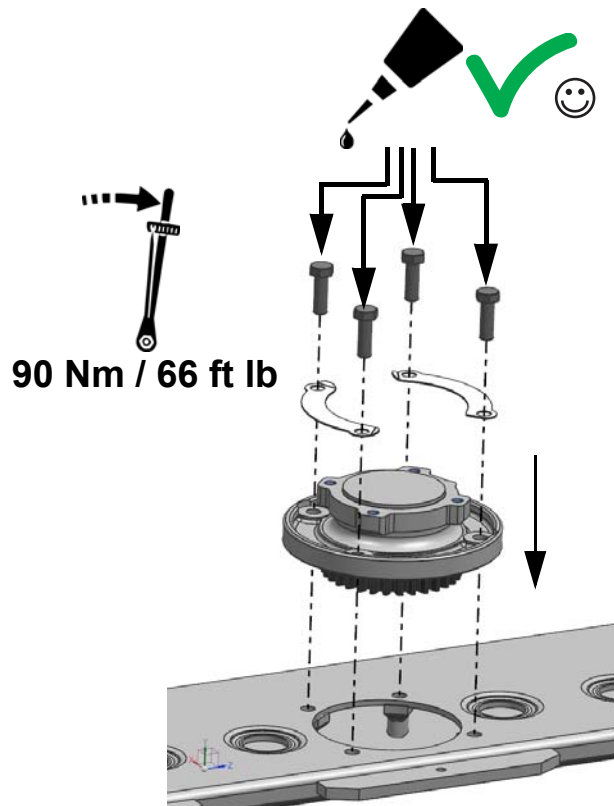

- ▶ Fit the bearing unit on the cutterbar.
- ▶ Fit the lock plates shown.
- ▶ Add Sealing on the bolts.
- ▶ Fit the bolts shown.

**NB!** Do not damage the O-rings.

Timing of the Hubs:

→ see page 25

→ see page 26

## Filling of Oil

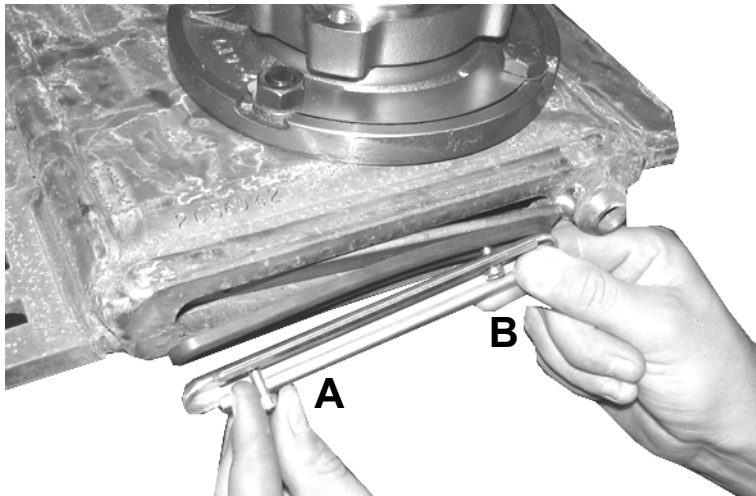

- i** **NB!** Always use a new gasket when the end cap is fitted.
- ▶ Guide the end cap in to the cutterbar as shown.
  - ▶ Tighten the end cap.

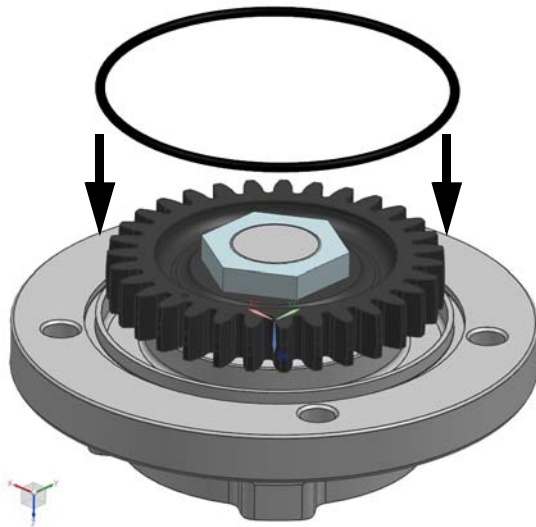

- ▶ Fit the O-ring on the Bearing units as shown.

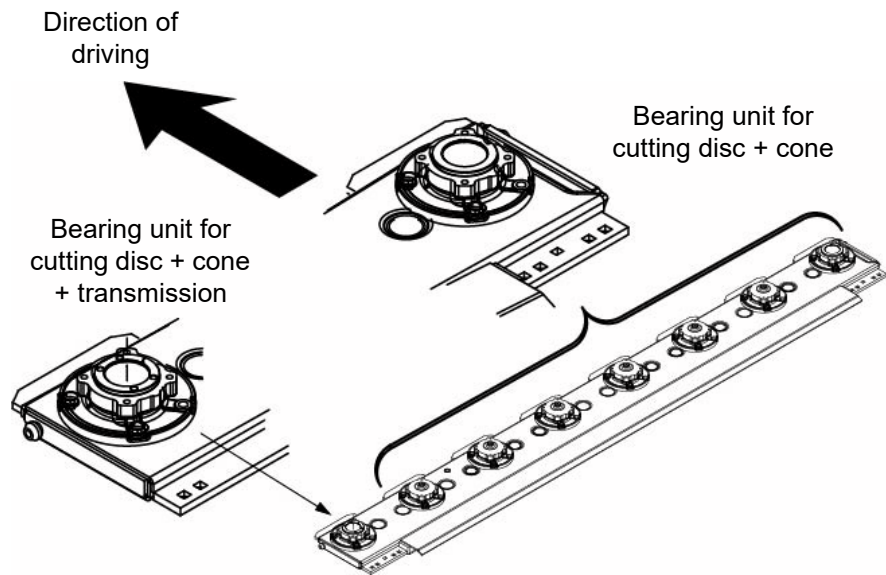

The 2 types of bearing units has to be fitted as shown.

## Direct powered Cutterbars

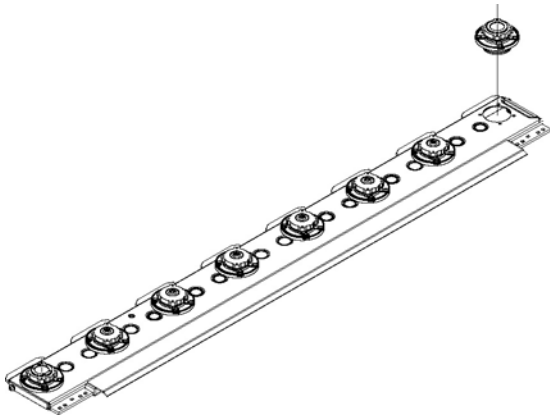
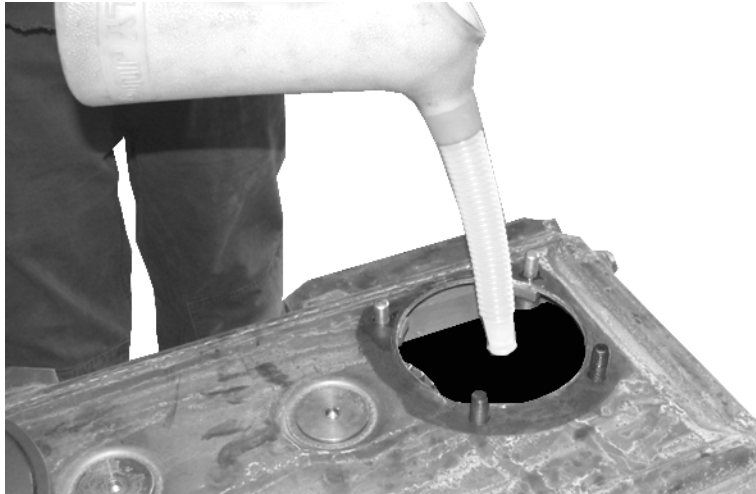

► Fill oil in to the cutterbar.

Kverneland & Case New Holland models		
Cutting width	No. of Cutting Discs	Volume of Oil Ltr. (approx.)
2,4 m	6	2,2
2,8 m	7	3,0
3,2 m	8	3,5
3,6 m	9	3,8
4,0 m	10	3,5

Vicon - Kubota & Deutz-Fahr models		
Cutting width	No. of Cutting Discs	Volume of Oil Ltr. (approx.)
2,4 m	6	2,2
2,8 m	8	2,8
3,2 m	8	3,5
3,6 m	10	3,5
4,0 m	10	3,5

► Fit the last bearing unit in the cutterbar (see next page).

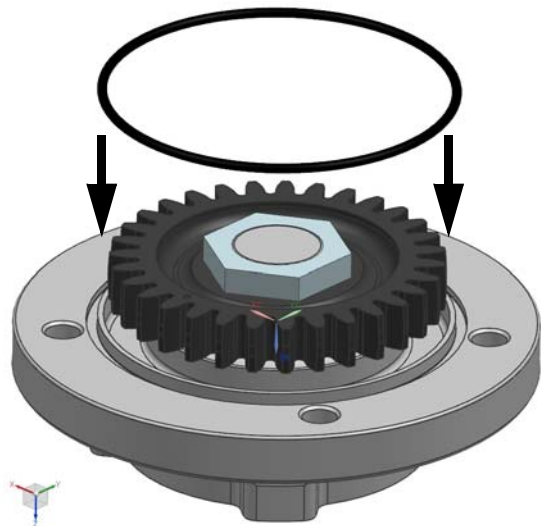

- ▶ Fit the O-ring on the Bearing units as shown.
- ▶ Fit the last bearing unit in the cutterbar.

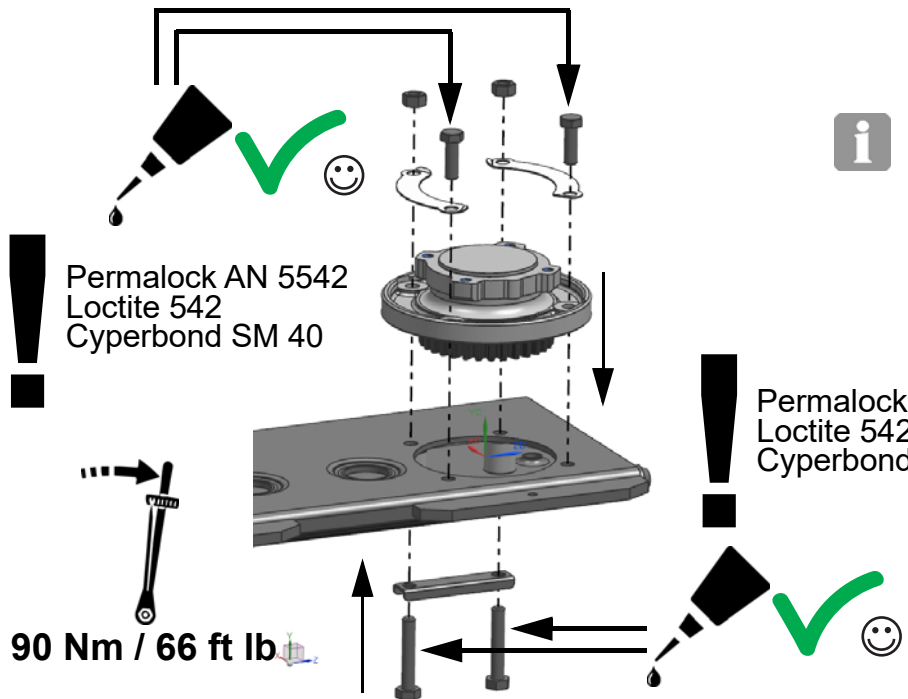

- ▶ Fit the bearing unit on the cutterbar.
  - ▶ Fit the lock plates shown.
  - ▶ Add Sealing on the bolts.
  - ▶ Fit the bolts and nuts shown.
- NB!** Do not damage the O-rings.

Timing of the Hubs:  
→ see page 25

## Indirect powered Cutterbars

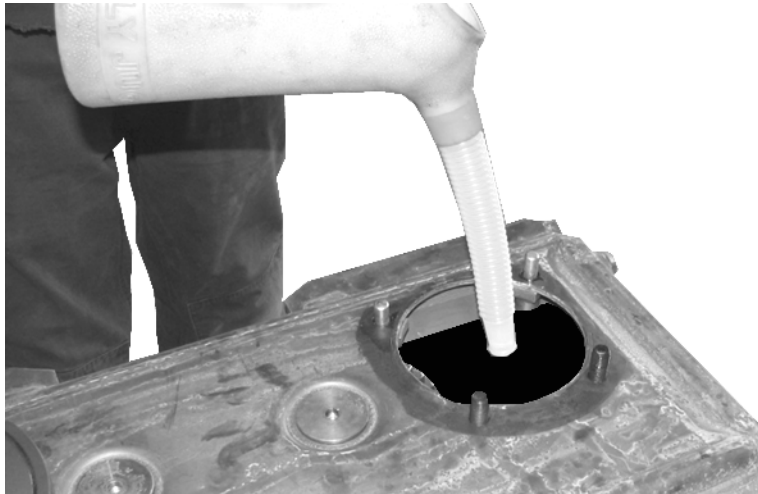

► Fill oil in to the cutterbar.

Kverneland models		
Cutting width	No. of Cutting Discs	Volume of Oil Ltr. (approx.)
1,6 m	4	1,7
2,0 m	5	1,9
2,4 m	6	2,4
2,8 m	7	3,3
3,2 m	8	3,5

Vicon - Kubota & Deutz-Fahr models		
Cutting width	No. of Cutting Discs	Volume of Oil Ltr. (approx.)
1,7 m	4	1,7
2,2 m	6	2,1
2,4 m	6	2,4
2,8 m	8	2,5
3,2 m	8	3,5

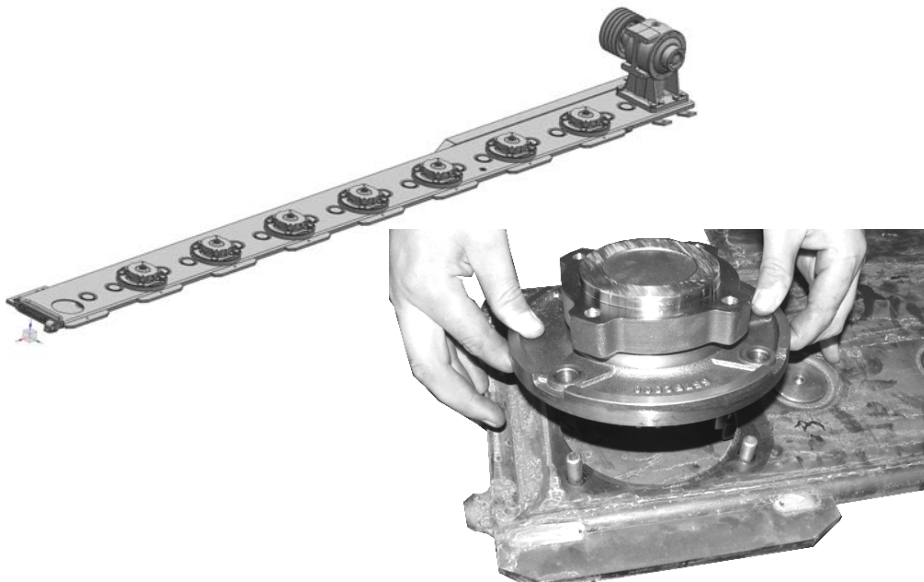

► Fit the last bearing unit in the cutterbar.

Timing of the Hubs:  
→ see page 26

# Timing of Bearing units

## Direct powered Cutterbars

Even numbers of cutting discs  
(4, 6, 8, 10 disc)

Drive line for  
main gear box.

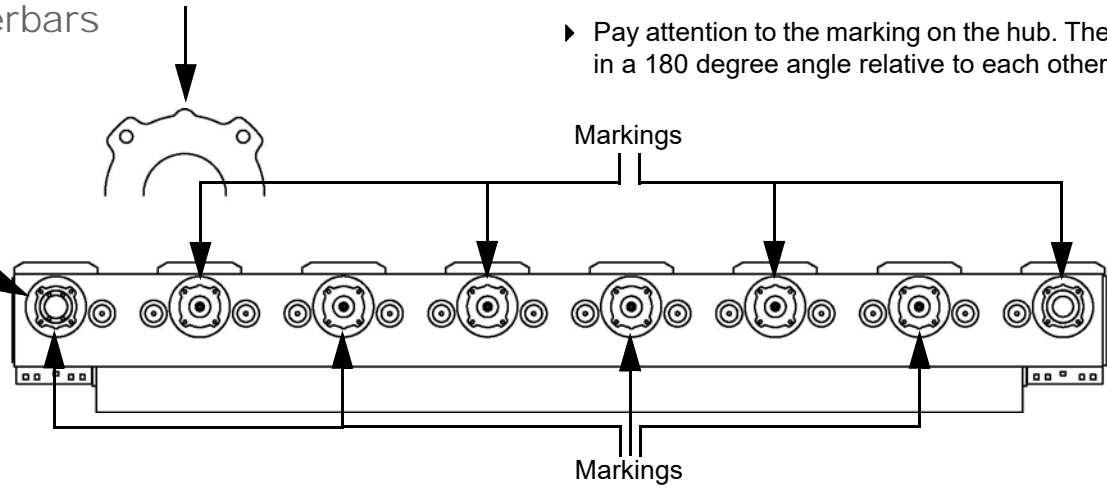

► Pay attention to the marking on the hub. These markings has to positioned in a 180 degree angle relative to each other as shown.

Odd numbers of cutting discs  
(5, 7, 9 disc)

Drive line for  
main gear box.

**NB!**

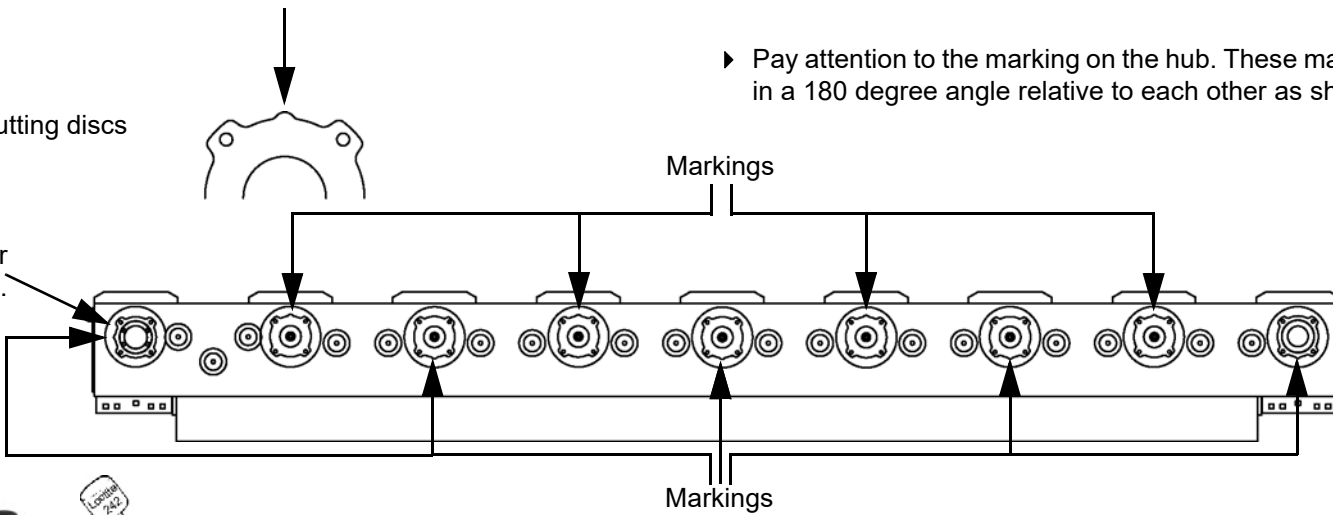

► Pay attention to the marking on the hub. These markings has to positioned in a 180 degree angle relative to each other as shown.

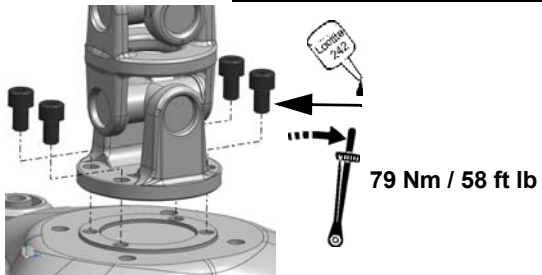

# Indirect powered Cutterbars

- ▶ Pay attention to the marking on the hub. These markings has to positioned in a 180 degree angle relative to each other as shown.

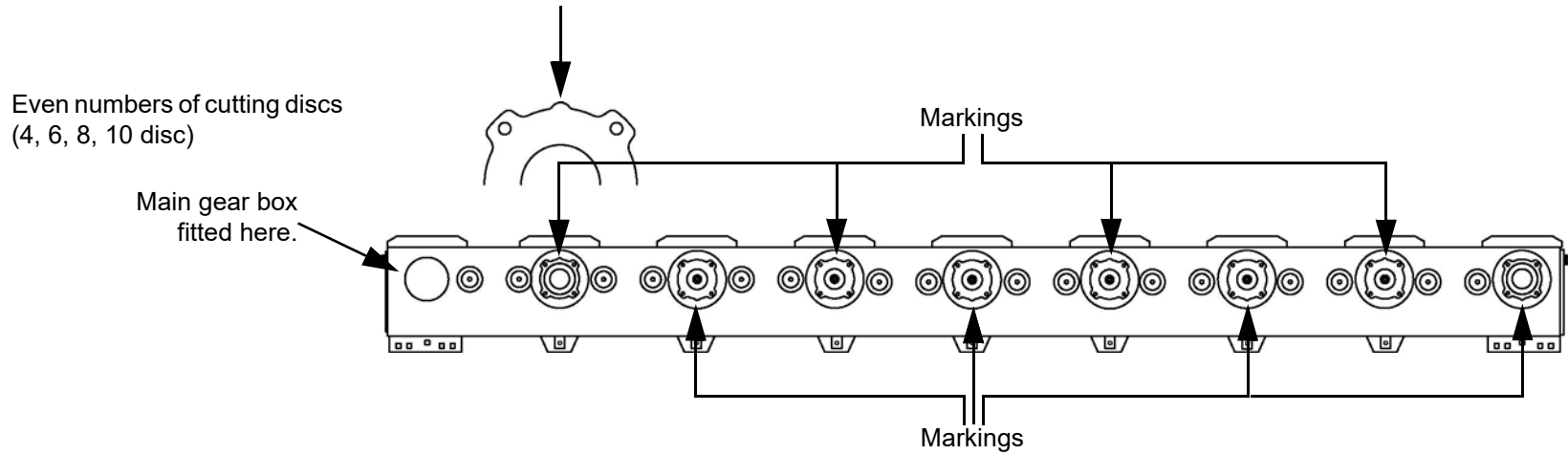

- ▶ Pay attention to the marking on the hub. These markings has to positioned in a 180 degree angle relative to each other as shown.

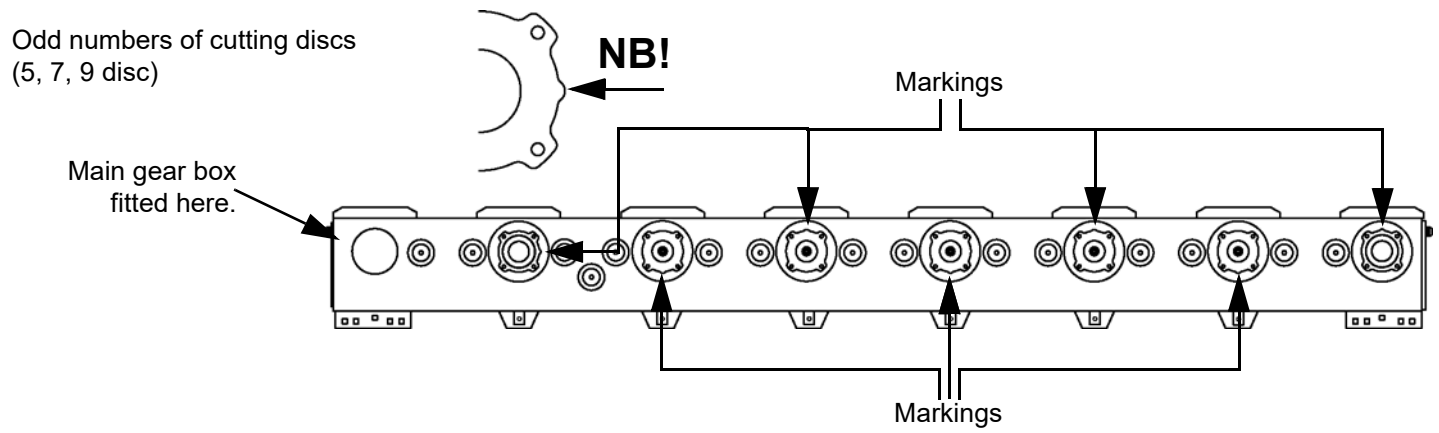

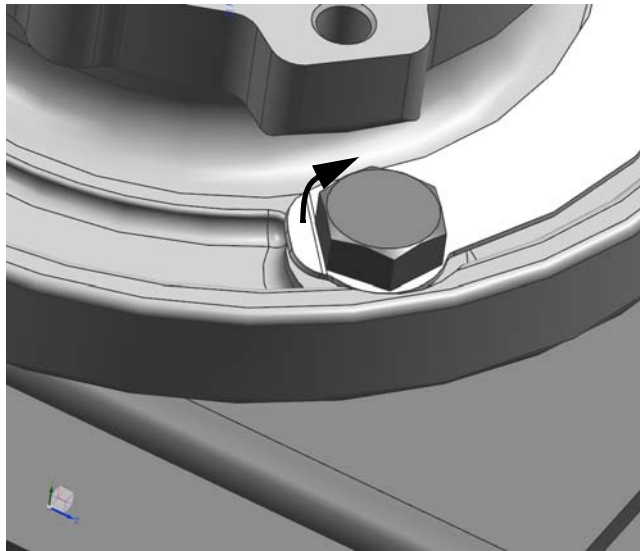

- ▶ Bend the lock plate around the head of the nut on all bolts.

Permalock AN 2270  
Loctite 270

80 Nm / 59 ft lb

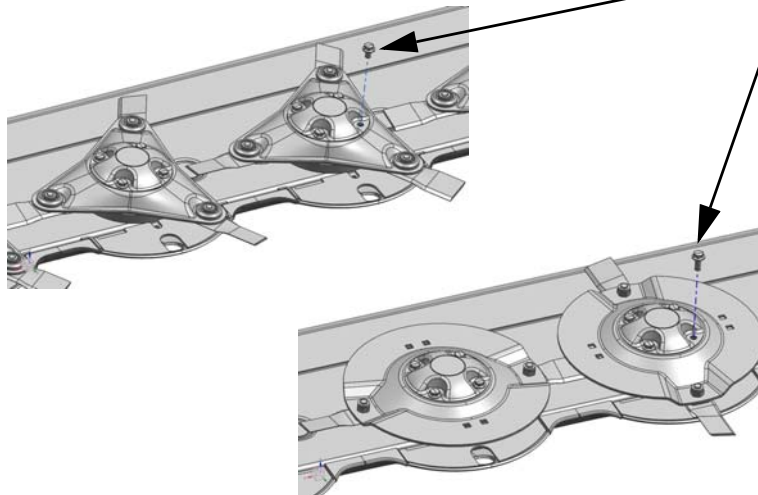

- ▶ Place the cutting discs on the bearing units as shown.
- NB!** Don't forget the caps on top of the cutting discs.
- ▶ Apply LOCTITE 242 or similar product on all bolts.
- ▶ Tighten the bolts with a torque of 80 Nm / 59 ft.lbs by use of a torque wrench.