

## SIGNUS

### Operating manual

Edition	7/2011
Printing	10.2011
Language	EN
For software from	1.04 / 1.05
For hardware version from	–
Article number	AC 754305

## Identification of the machine

Your dealer will require certain information about your machine to be able to help you as quickly as possible. Please enter the following data.

Designation

SIGNUS

Working width

Weight

Machine number

Accessories

Address of dealer

Manufacturer's address

Kverneland Group Soest GmbH  
Coesterweg 42

D-59 494 Soest

Telephone +49 (0)2921 / 974-0

<b>First of all .....</b>	<b>4</b>
Target group for this operating manual	4
Meaning of the symbols	4
<b>Safety .....</b>	<b>5</b>
<b>Becoming familiar with the machine .....</b>	<b>6</b>
Range of application of the implement	6
Features	7
An overview of the device	8
Technical data	10
Functions	10
<b>Delivery and assembly/installation .....</b>	<b>11</b>
Checking the scope of delivery	11
Assembly	11
<b>Connecting up the machine .....</b>	<b>12</b>
Safety	12
Connecting a device	12
<b>Operation.....</b>	<b>13</b>
Switch on	13
Using the buttons	13
Basic settings	14
Electrical seed rate adjustment [+]	26
Tramlining rhythm instructions	29
<b>Removal, storage.....</b>	<b>37</b>
Removal	37
Storage	37
<b>Removing faults.....</b>	<b>38</b>
<b>Disposal.....</b>	<b>40</b>
<b>The EC Conformity Declaration .....</b>	<b>41</b>
According to EC Directive	
2004/108/EC	41
<b>Index .....</b>	<b>42</b>

## Target group for this operating manual

This operating manual is designed for use by trained agriculturists and persons who are otherwise qualified to work in agriculture and who have received instruction on how to use this machine.

### For your safety

Please familiarise yourself with the contents of this operating manual before commissioning or assembling the machine. You will thereby achieve optimum performance results and operational safety.

### As an employer

All personnel are to be instructed on a regular basis, but at least once a year, according to the provisions of Employer's Liability Insurance Association, Article 1. Untrained or unauthorised persons should not use the machine.

## Instruction

You will receive instruction from your dealer about machine operation and maintenance.

## Meaning of the symbols

We have used various symbols in the text to make the presentation clearer. They are described below:

- A bullet point stands next to enumerations

> A triangle is placed before activities which you should undertake

→ An arrow indicates cross-references to other text passages

[+] A plus sign indicates that the item is an accessory which is not part of the standard version.

We also use pictograms which will aid you in finding text passages:



The hazard warning triangle refers to important safety instructions. Nonobservance of these can lead to the following consequences:

- Serious malfunctioning of the machine
- Damage to the machine
- Personal injury or accidents



This symbol indicates information, tips and instructions about operation.



This symbol indicates tips for assembly or adjustment work.



This symbol indicates examples that assist understanding of the instructions.



### **Checking the cables**

Check cables before connecting them up and replace damaged cables. Damaged cables can result in damage to the machine or cause uncontrolled behaviour in the electronic control system.

### **Pay attention to the temperature range**

The device will only operate reliably within the specified temperature range. Higher or lower temperatures can lead to uncontrolled behaviour in the electronic control system.

### **What to do in the event of malfunctions**

Stop working immediately if a malfunction occurs and switch off the device. Refer to the chapter »Removing faults« (Rectifying faults) and remove the fault. Inform our Customer Service Department if the fault cannot be removed. Continuing to operate a faulty machine can lead to major damage to the machine and errors in the seed deposit.

### **Maintenance work**

Disconnect the power supply when conducting maintenance work. It may prove impossible otherwise to exclude damaging the device.

# Becoming familiar with the machine

---

This chapter contains general information about your machine as well as information about:

- Range of application
- Features
- Technical data and
- Functions

## **Range of application of the implement**

The device is designed for use in agriculture. It controls agricultural machinery and devices.

## **Intended use**

The device is designed to be used in conjunction with agricultural machinery and devices for controlling and monitoring their functions. Any other use is forbidden.

## **Mode of operation**

Functions can be monitored, and track markers and the laying down of tramlines can be controlled automatically..

# Becoming familiar with the machine

## Features

Control and monitoring are possible using a terminal in connection with further components on the respective machine which can be matched to the type of machine being used. The overall system consists of the components

- Terminal
- Job computer
- Travel sensor
- and possibly other sensor or actuators

The individual functions are shown graphically in the display. We have dispensed with text as far as possible.

## Terminal

The terminal serves to enter and monitor seeding values.

## Job computer

The job computer creates the connection between the terminal, sensors and actuators. It is mounted on the seeding machine.

## Travel sensor

A travel sensor determines the distance travelled.

# Becoming familiar with the machine

## An overview of the device

### The front side

The overview shows the display and all of buttons which have each been allocated a function. The exact functions involved are described in the appropriate place.

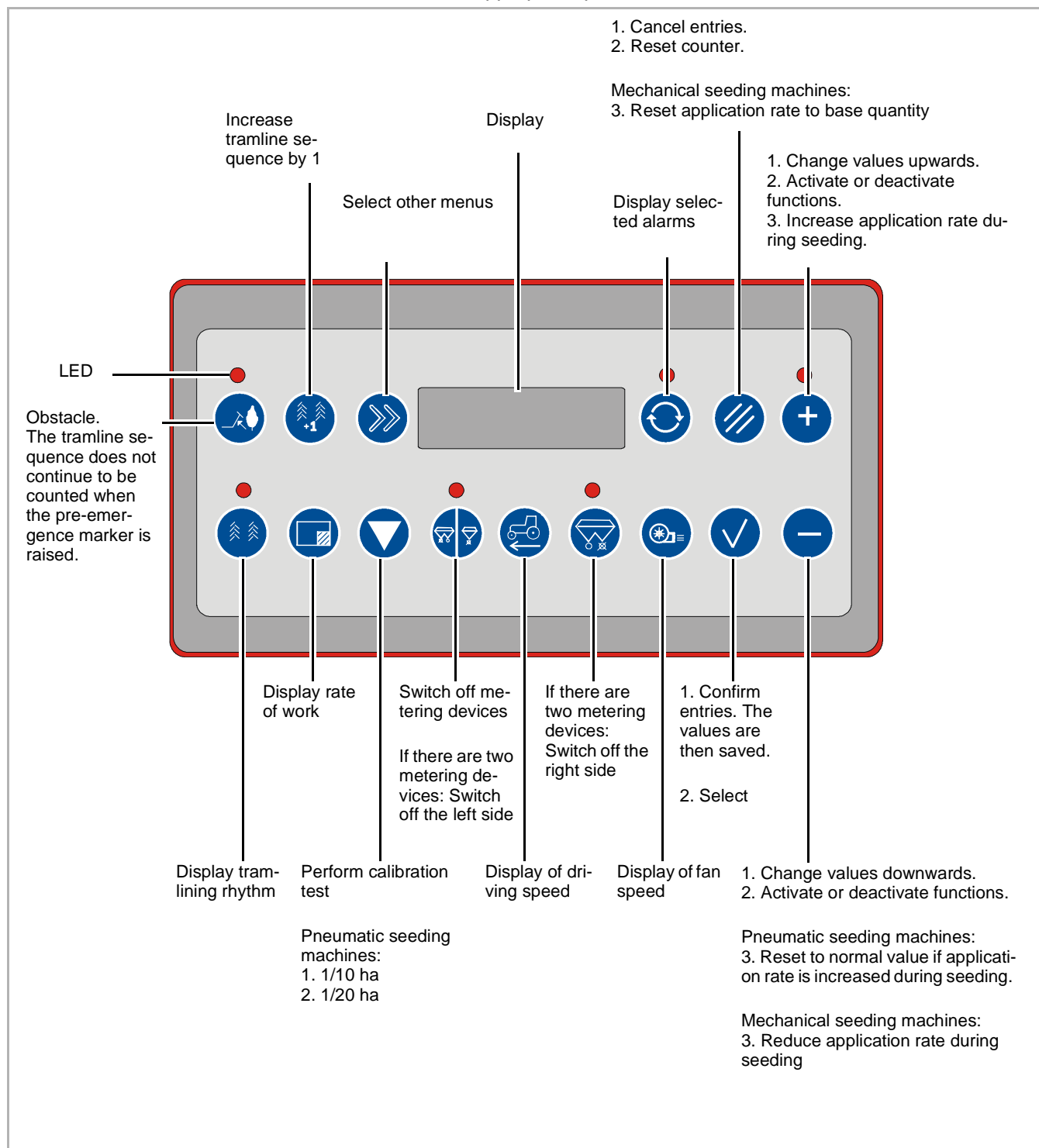

# Becoming familiar with the machine

## The rear side

The overview shows all connections on the rear side.

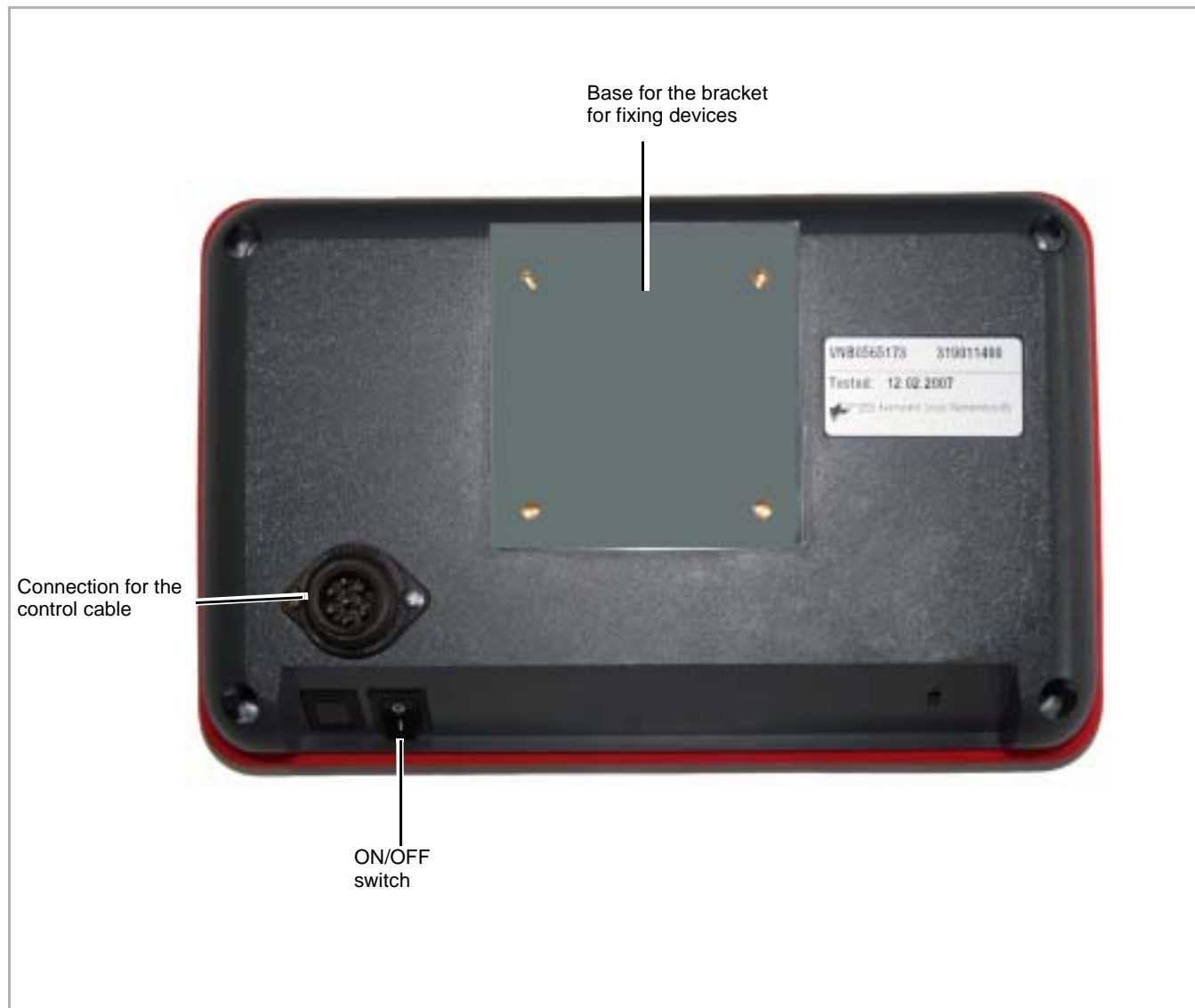

# Becoming familiar with the machine

## Technical data

SIGNUS	
Power supply (V) DC voltage	12-14
Safety fuse (A) <ul style="list-style-type: none"><li>• Job computer</li></ul>	30
Protection classes <ul style="list-style-type: none"><li>• Terminal</li><li>• Job computer</li></ul>	IP 54 IP 67
Temperature range (°C)	-10 to +50

## Functions

The device has the following functions in the case of pneumatic seeding machines:

- Automatic tramlining control system
- Automatic tramlining if pre-emergence marker fitted
- Seed rate adjustment
- If there is one metering device: Switch off the metering device  
If there are two metering devices: Separate off switch for left or right metering device
- Monitoring of fan speed, hopper low level sensor and driving speed, power supply
- Support for calibration test
- Determination of the area processed
- Display of driving speed
- Display of fan speed

The device has the following functions in the case of mechanical seeding machines:

- Automatic tramlining control system
- Automatic tramlining if pre-emergence marker fitted
- Seed rate adjustment, only in conjunction with electric motor
- Monitoring of hopper low level sensor, driving speed and power supply
- Support for calibration test
- Determination of the area processed
- Display of driving speed

## Checking the scope of delivery

For the electrical controller:

- Terminal
- Bracket for mounting on tractor
- Power cable from tractor battery, including socket for mounting on tractor



A claim should be made without delay to your dealer, the importer or the manufacturer for any missing parts or parts which have been damaged during transport.

## Assembly

The following items are mounted on the seeding machine at delivery:

- Job computer with connection cable to terminal
- Travel sensor
- Possibly other sensors such as a hopper low level sensor

## Terminal

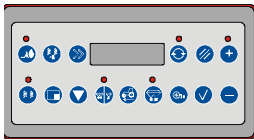

### Maintain defined minimum distance

When mounting the terminals, a minimum distance of one metre from mobile telephones, radios or radio antennae must be maintained. Unforeseen malfunctions could occur if the distance is too small.

### Ensuring a good view

The terminal must not limit the operator's view. Access to all functions of the tractor must remain unimpaired. Accidents can arise if the operator's view is blocked or there are impairments to operating tractor functions.

- > The terminal should be mounted in the tractor in such a way that you can easily read the display and can easily reach all operating buttons.

# Connecting up the machine

Prerequisites for connecting up the machine are:

- The machine is coupled to the tractor.
- All components are installed in an orderly manner.
- All cables and plugs are in perfect condition.

## Safety



### Checking the cables

Check cables before connecting them up and replace damaged cables. Damaged cables can trigger unexpected malfunctions.

### Pay attention to the temperature range

The device will only operate reliably within the specified temperature range. Higher or lower temperatures can trigger unexpected malfunctions.

## Connecting a device

Two or three cables may be needed for operation, depending on equipment:

- Cable from job computer on seeding machine to terminal.
- Possible cable to another machine such as a front seed hopper or blanking plug.
- Power cable from job computer to tractor.

### Cable from job computer on seeding machine to terminal

- > Connect plug to the rear of the terminal
- > Secure plug

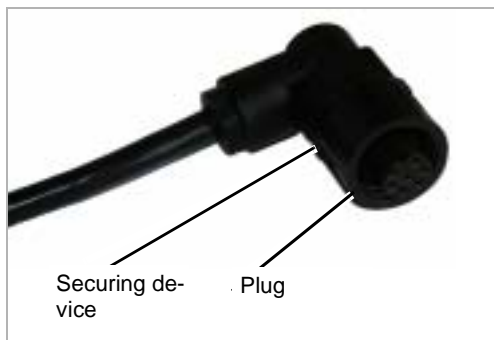

### Power cable from job computer to tractor

- > Remove dust cap.
- > Connect plug to socket on tractor.



## Switch on



The system is ready to operate after being connected up and can be switched on.

> Press the On-Off switch on the terminal

The system performs a short self-test. The type of machine set (for example "Pneumatic seed drill") is displayed for a few seconds.

When the current driving speed is displayed, the test is complete.

## MSC

With MSC seeding machines, when you switch on the device, hydraulic operation is placed on the track marker. The controller on the tractor then only sets the track marker. If the machine is to be folded in or out, you must switch off Signus.

Function	SIGNUS
Actuate the track marker	Switch on
Fold the machine in or out	Switch off

## Using the buttons



Button for scrolling through or selecting items in menus.



1. Confirm entries. The values are then saved.
2. Select menus.



1. Change values up or down
2. Activate or deactivate functions

### Pneumatic seeding machines:

3. Increase application rate by 20% during seeding or reset to normal level if application rate is increased during seeding.

### Mechanical seeding machines:

3. Change application rate up or down by up to 2 scale values during seeding.

# Operation

## Basic settings

A few adjustments need to be made so that the electronic controller can perform at its best with your machine.



> Press the button. Press several times to scroll through the options in the selection menu.



> Press the button to select

## Selection menu

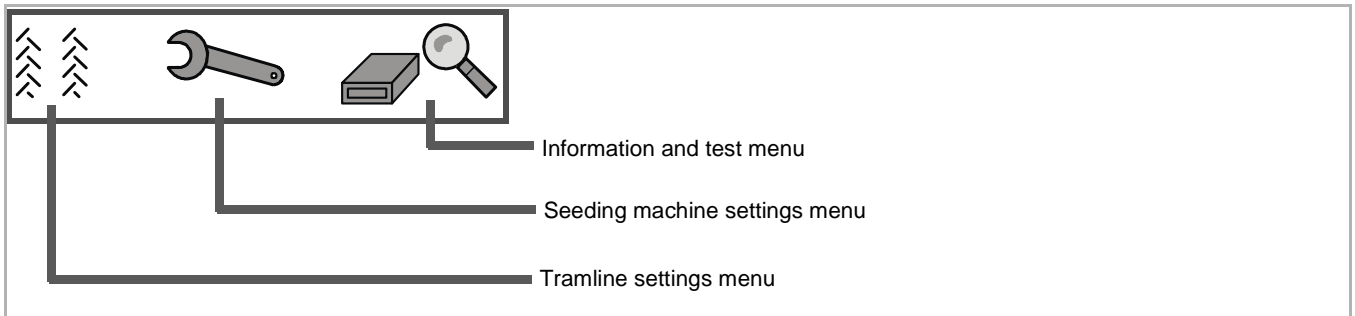

## Tramline settings menu



Tramlines are laid down for spraying/fertilising units such as field sprayers or fertiliser spreaders. The details of the machine's working width are vital for a correct calculation.

→ Chapter »Operation«, section »Seeding machine settings menu«, page 16.

A message will appear if you specify combinations that are invalid for tramlines.

→ Chapter »Removing faults«, page 38.

The tramlines are calculated automatically. However, by way of information, we have provided some basic details on laying down tramlines.

→ Chapter »Operation«, section »Tramlining rhythm instructions«, page 29



Choose whether to lay down tramlines or not.

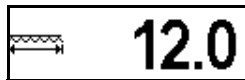

Working width of the spraying/fertilising unit in metres, for example field sprayers or fertiliser spreaders.

### Tramline selection (only displayed if choice is possible)



Laying down tramlines symmetrically. Both tramlines will be laid down in one pass.



Laying down tramlines asymmetrically. Just one tramline will be laid down in one pass.

### Display of field side where seeding work starts.



Beginning the seeding work at the left-hand side of the field.

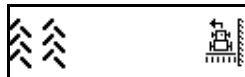

Beginning the seeding work at the right-hand side of the field.

# Operation

## Seeding machine settings menu



Basic settings refer to machine data which is important for controlling functions or triggering alarms.

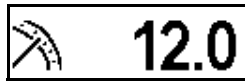

Display only for mechanical seeding machines with activated electrical seed rate adjustment.  
Display of the current seeding value.



### Checking adjuster lever

If the value is changed, the lever travels to the set position. The lever must not be impeded or blocked. If it is, the drive for electrical seed rate adjustment could be destroyed.



### Changing the seeding value:

> Adjust seeding value up or down

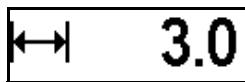

Enter the working width of the machine in metres.



### Selecting the travel sensor

Travel sensor from seeding machine drive wheel.



Radar sensor on the tractor.

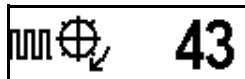

If the seeding machine has a drive wheel: Enter number of pulses over 100 metres.

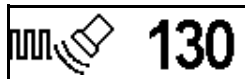

If the tractor has a radar sensor: Enter number of pulses over 100 metres.

There are options for entering values:

### 1. Calibrating the travel sensor

The travel sensor receives one pulse per rotation of the drive wheel. The travel sensor must first be calibrated in order to assign a number of pulses to a track. To do this, you need to travel exactly 100 m in the field.

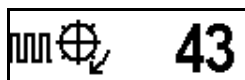

- > Press the button in the menu. The memory is cleared.
- > Drive exactly 100 m in the field, then save the number of pulses shown by pressing the button.

## 2. Accepting table values (drive wheel)

The values in the table depend on the outside circumference of the drive wheel on your seeding machine and the soil conditions. The current soil conditions may produce different values. Calibration over the distance actually travelled on the field is more accurate.

Seeding machine	Pulse generator	Pulses/100 m
DL	Drive wheel 7.00-12	50
DL	Drive wheel 26.00-12.00	49
DT	Drive wheel 7.50-16	41
DT / DV / DC	Drive wheel 31-15.50	43
m-drill, 2.50 m	Drive wheel	1305
m-drill, 3.00 m	Drive wheel	1305
m-drill, 4.00 m	Drive wheel	1236
Mecasem, 2.50 m	Drive wheel	1305
Mecasem, 3.00 m	Drive wheel	1305
Mecasem, 4.00 m	Drive wheel	1236
Other seeding machines	Star wheel	42

You can find the table values for the radar sensor on the tractor in the relevant operating manual.



### Selecting alarms

Activate or deactivate the sensor on the metering device shaft. If there are two metering devices, they can be activated or deactivated individually.



Activate or deactivate fan sensor, if fitted.

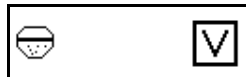

Activate or deactivate the hopper low level sensor. If there are two hopper low level sensors, they can be activated or deactivated individually.

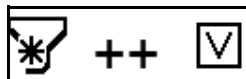

### Display for pneumatic seeding machines only.

Activating or deactivating electrical seed rate adjustment, if fitted.

### Display for mechanical seeding machines only.



### Checking adjuster lever

If the value is changed, the lever travels to the set position. The lever must not be impeded or blocked. If it is, the drive for electrical seed rate adjustment could be destroyed.



Activating or deactivating electrical seed rate adjustment, if fitted.



### PIN

Enter PIN. The subsequent menu items can only be changed using a PIN. Changes should only be made by a trained service technician. The set values can be displayed for information purposes without using a PIN.

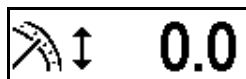

Calibration of the electrical seed rate adjustment



Number of metering devices on the machine.

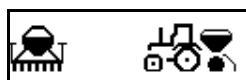

Machine type, for example, mounted pneumatic seeding machine.

## Test menu

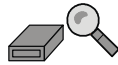

The test menu provides a summary of software versions and allows you to check individual seeding machine functions.



Terminal software version.

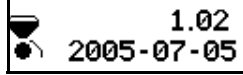

Job computer software version. More software version displays may follow, depending on the configuration.



Voltage [V] at terminal.



Voltage [V] at job computer. More power supply displays may follow, depending on the configuration.



Display for mechanical seeding machines only.



### Checking adjuster lever

If the value is changed, the lever travels to the set position. The lever must not be impeded or blocked. If it is, the drive for electrical seed rate adjustment could be destroyed.

Testing the drive motor for electrical seed rate adjustment. Move to the top or bottom position.

## Testing sensors

The display switches between 0 and 1 during testing. If the display does not change, the sensor or the signal line is defective. Sensors may or may not be fitted, depending on machine equipment.



1

Test sensor of metering device drive. Turn the drive wheel manually. If there are two metering devices, each sensor can be tested.



1

Testing drive wheel sensor of seeding machine. Turn the drive wheel manually.



1

Test hopper low level sensor. Activate and release the hopper low level sensor. If there are two hopper low level sensors, they can be tested individually.



1



1



0

Test fan sensor. Turn the fan slowly by hand.  
→ See operating manual for pneumatic seeding machine.

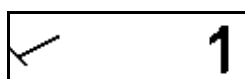

1

Test the left-hand sensor on the track marker. Raise and lower the track marker.

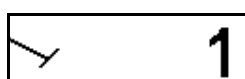

1

Test the right-hand sensor on the track marker. Raise and lower the track marker.



## Test actuators

Test shutoff valves for laying down tramlines, left-hand side.



Test shutoff valves for laying down tramlines, right-hand side.



Test motor on metering device to increase the application rate.



Test metering device cut-off. If there are metering devices, they can be tested individually.



Test the operation of the LED displays. Press the top left button on the terminal. All LEDs come on.



## PIN

Enter PIN. The subsequent menu items can only be changed using a PIN. Changes should only be made by a trained service technician. The set values can be displayed for information purposes without using a PIN.



Reverting to factory settings.



Total number of prepared fields in hectares.

# Operation

## The buttons

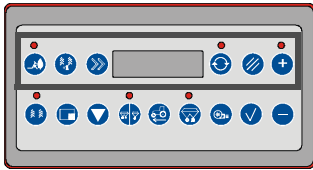

The buttons and functions are described here in turn, running from left to right, as they occur on the terminal.

### Obstacle

Press button for raising track marker. The tramline sequence is not increased then when the track marker is raised. When the button is pressed, its LED comes on to indicate that the tramline sequence is not being increased.



### Example

Obstacle on right side:

- > Press "Obstacle" button
- > Raise right track marker
- > Lower then raise left track marker
- > Drive around obstacle
- > Lower right track marker
- > Press "Obstacle" button again

The tramline sequence is not increased and no correction is needed.



Increasing current tramline sequence by 1.



Scrolling. Press several times to scroll through the options in each menu.

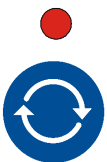

Alarm confirmation. The LED above the button stays on until the alarm is confirmed. If several alarms occur at the same time, you can use the button to scroll through the alarm messages.



1. Cancel entries. Here, either a previously saved value or one of the factory settings will be used. A new value must be saved in any case.
2. Reset counter. For example, the daily counter for the worked area can be reset.

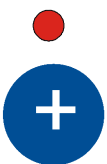

1. Within the menu: Change values upwards.
2. Activate or deactivate functions such as activating or deactivating sensors.
3. Increase application rate during seeding. This function is active if no menus for entries or activations are open. It is only possible to change the application rate if a driving speed has been registered by the drive wheel or the radar on the tractor or, in the case of pneumatic seeding machines, if the drive shaft on the metering device is turning. When the button is pressed, its LED comes on to indicate that the sowing quantity is being increased.

→ Chapter »Operation«, section »Electrical seed rate adjustment [+]"«, page 26

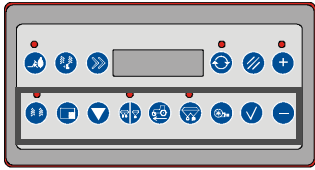

Show current pass in tramlining rhythm.

For example: 2:4 means that 4 passes are needed for a tramline rhythm, and the current pass is no. 2. If a tramline is being laid during the current pass, the LED above the button comes on for information purposes.

If a "0" is shown for the first pass, it is being driven at half working width.

- > Turn off half the working width and begin drilling on the corresponding side of the field. This pass is not counted in the tramline sequence.
- > Drill on the return pass using the complete working width. This is then pass "1" of the tramline sequence. Do not drive in the track marker track, but along the boundary of the surface cultivated in the first pass.



Display processed area in hectares. There are 3 displays that can be deleted independently of each other.

- |              |   |
|--------------|---|
| 1 x press:   | Display the processed area to an accuracy of 1/100 ha (e.g. for 1 field).<br>Max. display 99.99.          |
| 2 x presses: | Display the processed area to an accuracy of 1/10 ha (e.g. for daily performance).<br>Max. display 999.9. |
| 3 x presses: | Display the processed area without commas (e.g. the weekly performance).<br>Max. display 9999.            |

# Operation



Calibration test help. During the calibration test, the sensor on the metering device counts the number of revolutions of the metering shaft. First of all, the number of revolutions needed are displayed:

## With normal metering

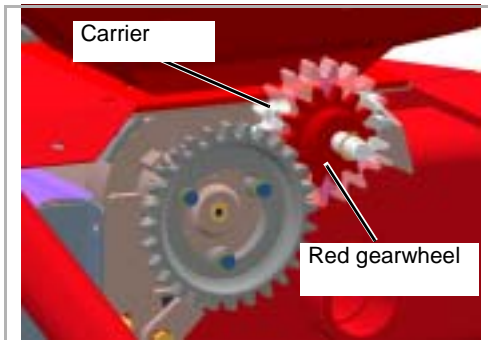

Requirements:

- The metering device of the seeding machine is set to normal metering.
  - The metering device cell wheels are filled.
- Operating manual of the seeding machine

For normal metering, the red gearwheel is in the carrier.

Metering device is set to normal metering			
Area	Number of revolutions of the calibration handle	Pneumatic seeding machines	Display
0.10 ha (recommended)	85	Press once	85
0.05 ha	42.5	Press twice	42

The counter then counts backwards. When it reaches "0", an alarm sounds.

## With micrometering system

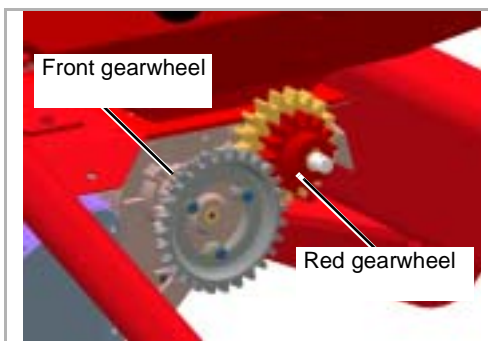

Requirements:

- The metering device of the seeding machine is set to micrometering.
  - The metering device cell wheels are filled.
- Operating manual of the seeding machine

For micrometering, the red gearwheel is locked into the front gearwheel.<

Metering device is set to micrometering			
Area	Number of revolutions of the calibration handle	Pneumatic seeding machines	Display
Do not use for micrometering		Press once	85
0.10 ha (recommended)	85	2 x presses:	42

The counter then counts backwards. When it reaches "0", an alarm sounds. Continue for one additional revolution.



One metering device: The metering device is switched off.  
Two metering devices: The left-hand metering device is switched off. When the button is pressed, its LED comes on to indicate that the metering device has been switched off.

Mechanical seeding machines: No function.



Display of current driving speed. This information comes from either the drive wheel on the seeding machine or the radar on the tractor.



Two metering devices: The right-hand metering device is switched off. When the button is pressed, its LED comes on to indicate that the metering device has been switched off.

Mechanical seeding machines: No function.



Display of current fan speed. You can enter the nominal value for the fan speed here. Should the fan speed fall more than 10 % below this value, an alarm will sound. Likewise, an alarm will sound for a fan speed greater than 5000 rpm.

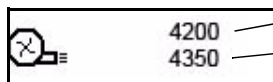

Nominal value for the fan speed  
Current value for the fan speed



The buttons can be used to increase or decrease the value. The value changes by 50 rpm. Save using the button.



You can use this button to adopt the current value as the nominal value for the fan speed. The value is saved at the same time.

Mechanical seeding machines: No function.



1. Confirm entries. The values are then saved. The old values are not changed unless this button is pressed.  
2. Select menu items



1. Within menus: Change values downwards.  
2. Activate or deactivate functions such as activating or deactivating sensors.  
3. If the application rate is increased by 20% during seeding, the rate is reset to the normal value.

# Operation

## Electrical seed rate adjustment [+]

Electrical seed rate adjustment can be used for the following seeding machines:

- Pneumatic seeding machines
- Mechanical seeding machines

However, the adjustment on the seeding machines is different.

## Pneumatic seeding machines

Electrical seed rate adjustment is only suitable for standard seed varieties. Once set, the additional amount of seed is activated or deactivated using the SIGNUS.

Before starting work, you must:

- Set the basic amount (100 %)
- Set the desired additional amount (+ x%)
- Turn the adjustment screw
- Check the additional amount with a calibration test.



The cell width of the metering device can be increased by a maximum of 20 mm using seed rate adjustment.

## Switch on electrical seed rate adjustment

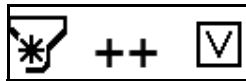

> Switch on electrical seed rate adjustment

## Basic amount

The basic amount is the amount of seed you want to distribute per hectare. You will already have set this amount and carried out a calibration test.

## Setting the additional amount

You calculate the set value for the additional amount as follows:



Example of additional amount calculation	
Given a basic seed amount setting of 100 % on the metering device	50 mm cell width
Desired additional amount	+ 10 %
Calculation	$50 \text{ mm} \times 10 \% / 100$
Result : Setpoint value for increased output	+5 mm cell width
After connecting seed rate adjustment	55 mm new cell width



Maximum cell width

Cell width for basic setting + cell width of additional amount must not exceed the maximum cell width of 110 mm.

## Turn the adjustment screw

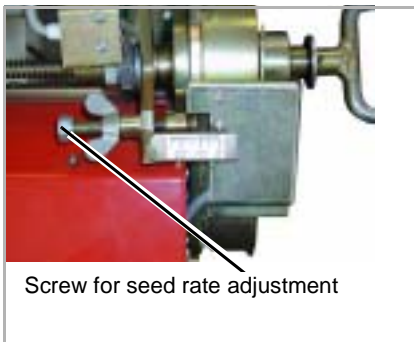

## Checking additional amount

You now set the calculated value for additional seed using the seed rate adjustment screw.

> Example: Turn the adjustment screw to 5 mm on the scale



- Do not exceed the maximum cell width of 110 mm, incl. seed rate adjustment.
- Increasing the cell width  
After the screw has been adjusted and the electrical seed rate adjuster has been switched on, the cell width is increased automatically to the set value.

After you have set the screw, check that the desired additional amount is being spread.

> Use the calibrating handle to rotate the metering device.

>  Press.

> Perform calibration test

# Operation

## Mechanical seeding machines

The following preparations are needed when using electrical seed rate adjustment:

- Switch on electrical seed rate adjustment
- Calibrate seeding value.



### Checking adjuster lever

If the value is changed, the lever travels to the set position. The lever must not be impeded or blocked. If it is, the drive for electrical seed rate adjustment could be destroyed.

## Switch on electrical seed rate adjustment



Switch on electrical seed rate adjustment.

## Basic amount

The basic amount is the amount of seed you want to distribute per hectare. You will already have set this amount and carried out a calibration test.

Changing the seed value:

→ Chapter »Operation«, section »Seeding machine settings menu«, page 16

Perform calibration test:

→ Operating manual of the seeding machine

## Setting the additional amount

>  Press.

The adjuster lever increases the seeding value by 0.5 scale units; the LED above the button comes on.

Press the button several times: The lever increases the seed value each time by 0.5 scale units up to a maximum of 2.0 scale units.



## Setting a lesser amount

>  Press.

The adjuster lever decreases the seeding value by 0.5 scale units; the LED above the  button comes on.

 Press the button several times: The lever decreases the seed value each time by 0.5 scale units up to a maximum of 2.0 scale units.

## Reset application rate to default amount

>  Press. The LED above the  button goes out.

## Tramlining rhythm instructions

The correct tramlining rhythm is calculated automatically from the combination of the working widths of the seeding machine and the spraying/fertilising unit. This chapter is just for information purposes.

The tramlining rhythm defines when tramlines are to be set up on the field. The number of blocked seed rows is determined by the track width and tyre width of the tractor you use for fertilising and spray work. At delivery, all settings are based on the information you provided at the time you ordered the machinery.



If the working width of the spraying/fertilising unit or the tractor's track width changes, please contact your dealer.

## Basics

Before you can set up tramlines, it may be necessary to make alterations to the seeding machine. This is always required if you want the tramlines for the spraying/fertilising unit to be different from the previous width. The installation or modification of shutoff valves is generally required. If these modifications are required, have them performed before setting up the tramlines.

The tramlining rhythm is calculated from the ratio of the spraying/fertilising unit working width and that of the seeding machine.



### Sample tramlining rhythm calculation

Field sprayer working width	20 m
Seeding machine working width	4 m
Calculation	$20/4=5$
Result	5

The working width ratio may also result in a remainder. How the various tramlining rhythms are handled is described in this chapter in the section »Select rhythm«.

# Operation

## Creating tramlines

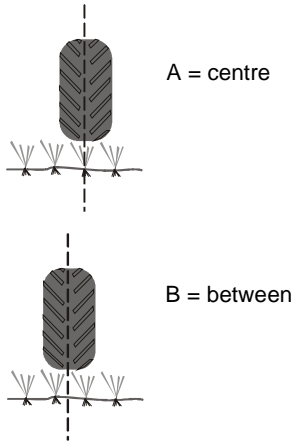

Setting tramlines by blocking the seed rows is dependent on:

- the tractor's track width
- the width of the spraying/fertilising unit, and
- the row distance.

The tractor track width can be dimensioned so that the tractor tyres:

- Drive over the centre of a seed row, or
- Drive between two seed rows.

Use the graphic in conjunction with the table. The following apply:

- A = the tractor travels over the centre of a seed row  
Please note: Select the number of blocked seed rows in such a way that the tractor tyres do not drive over a seed row.
- B = the tractor travels between two seed rows,  
Please note: Select the number of blocked seed rows in such a way that the tractor tyres do not drive over a seed row.



For particularly wide tyres, you will need to block several adjacent seed rows to set up the tramline.

The table lists possible tractor track widths dependent on the row distance.

Row distance [cm]	Working width of seeding machine [m] and (number of seed rows)	Spraying/fertilising tractor track width [m]								
		A	B	A	B	A	B	A	B	A
11.9	2.50 (21)	–	–	1.67	1.79	1.90	–	–	–	–
14.3	3.00 (21)	1.43	1.57	1.72	1.85	2.00*	–	–	–	–
13.0	3.00 (23)	–	1.43	1.56	1.69	1.82	1.95	2.08*	–	–
12.0	3.00 (25)	1.44	1.56	1.68	1.80	1.92	2.04	2.16*	–	–
13.8	4.00 (29)	1.38	1.52	1.66	1.79	1.93	2.07	2.21	–	–
12.1	4.00 (33)	1.45	1.57	1.69	1.82	1.94	2.06	2.18	–	–
11.1	4.00 (36)	1.41	1.50	1.59	1.69	1.78	1.88	1.97	–	–
10.3	6.00 (58)	1.34	1.43	1.55	1.65	1.75	1.86	1.96	–	–
12.5	6.00 (48)	1.38	1.50	1.63	1.75	1.80	2.0	–	–	–
15.0	6.00 (40)	1.35	1.50	1.65	1.80	1.95	2.10	–	–	–

## Calculate the rhythm

The table is merely intended as an overview. The table lists some of the most common tramlining rhythms of the seeding machine, dependent on the spraying/fertilising unit working width (m), e.g. field sprayers, fertiliser spreaders.

### Overview

Common tramlining rhythms							
Working width of spraying/fertilising unit (m)	Working width of seeding machine (m)						
	2.50	3.00	4.00	4.50	6.00	8.00	9.00
9	–	3	–	2	–	–	–
10	4	3.3	–	–	–	–	–
12	–	4	3	–	2	–	–
15	6	5	–	–	2.5	–	–
16	–	–	4	–	–	2	–
18	–	6	4.5	4	3	–	2
20	8	–	5	–	3.3	2.5	–
21	–	7	–	–	3.5	–	–
24	–	8	6	5.3	4	3	–
27	–	9	–	6	4.5	–	3
28	–	–	7	–	–	3.5	–
30	12	10	7.5	–	5	–	–
32	–	–	8	–	–	4	–
36	–	12	9	8	6	–	4

# Operation

The following chart contains several examples of tramlining rhythms.

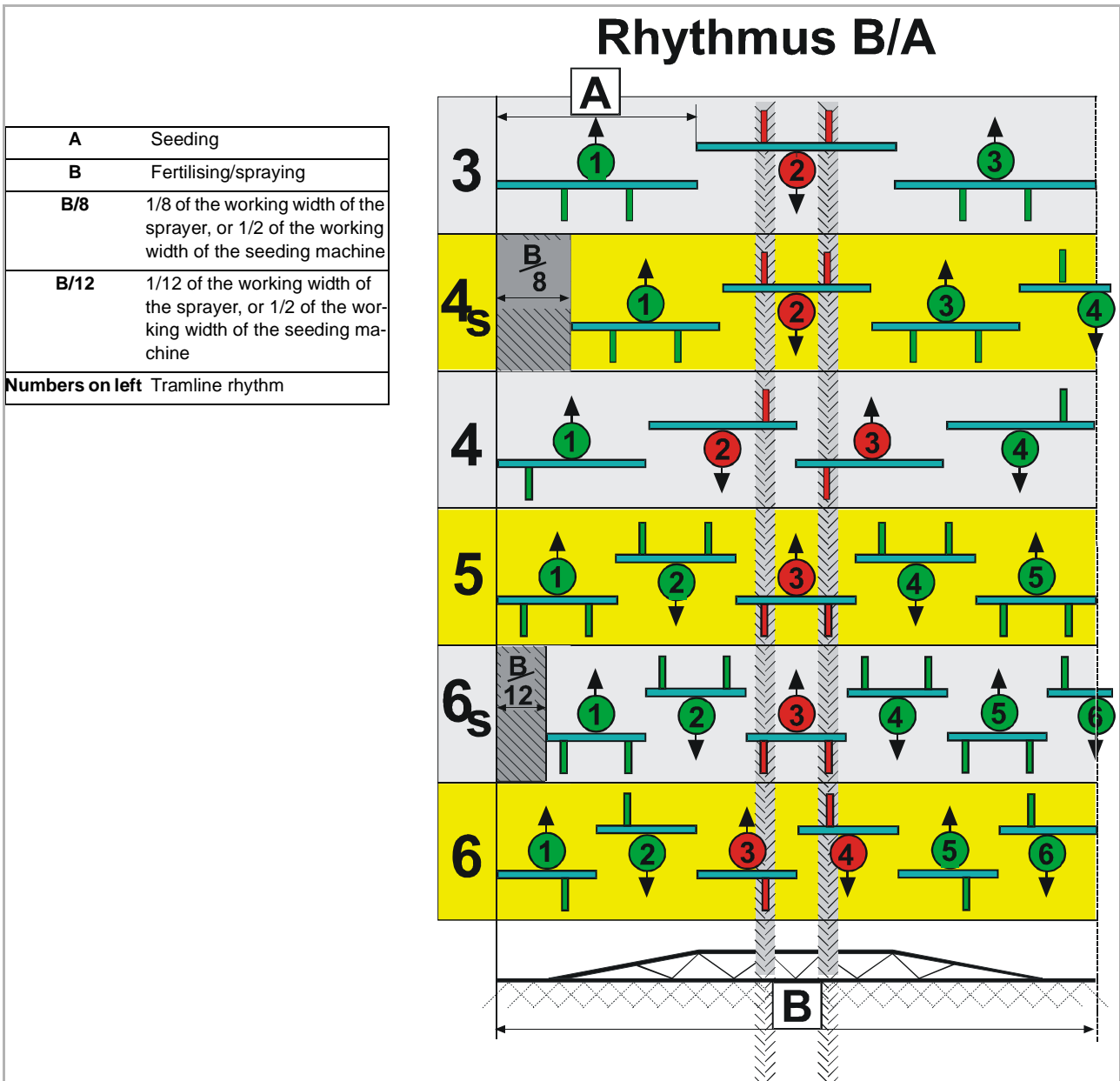

Example of a tramlining rhythm with a remainder:

- 18 m spraying/fertilising unit
- 4 m seeding machine

**Start at the right edge of the field**

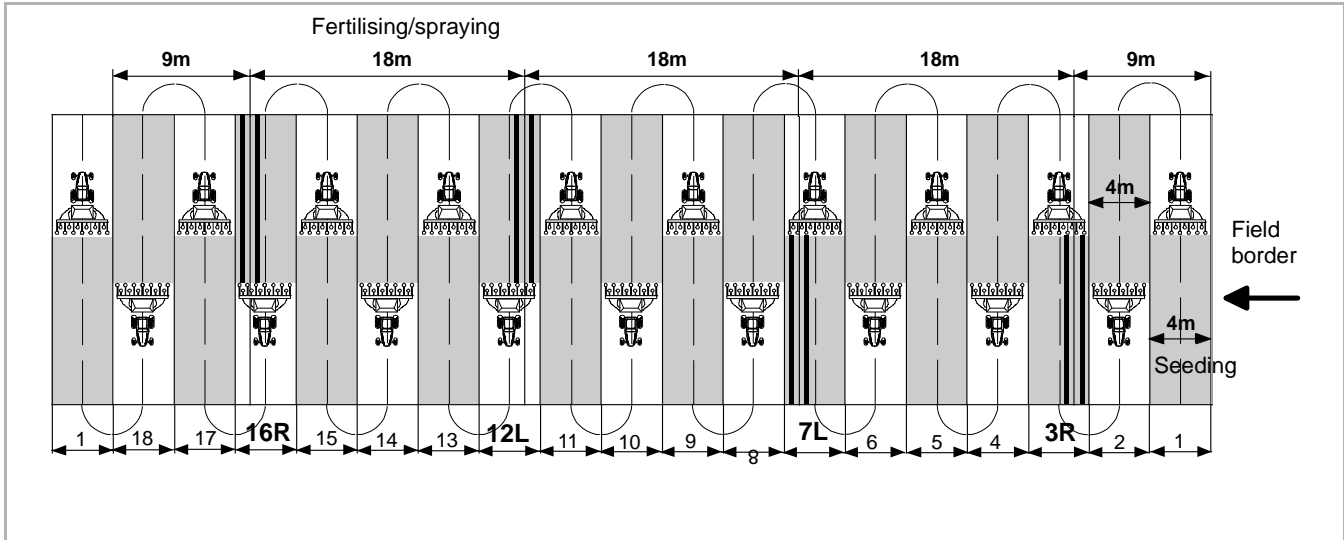

**Start at the left edge of the field**

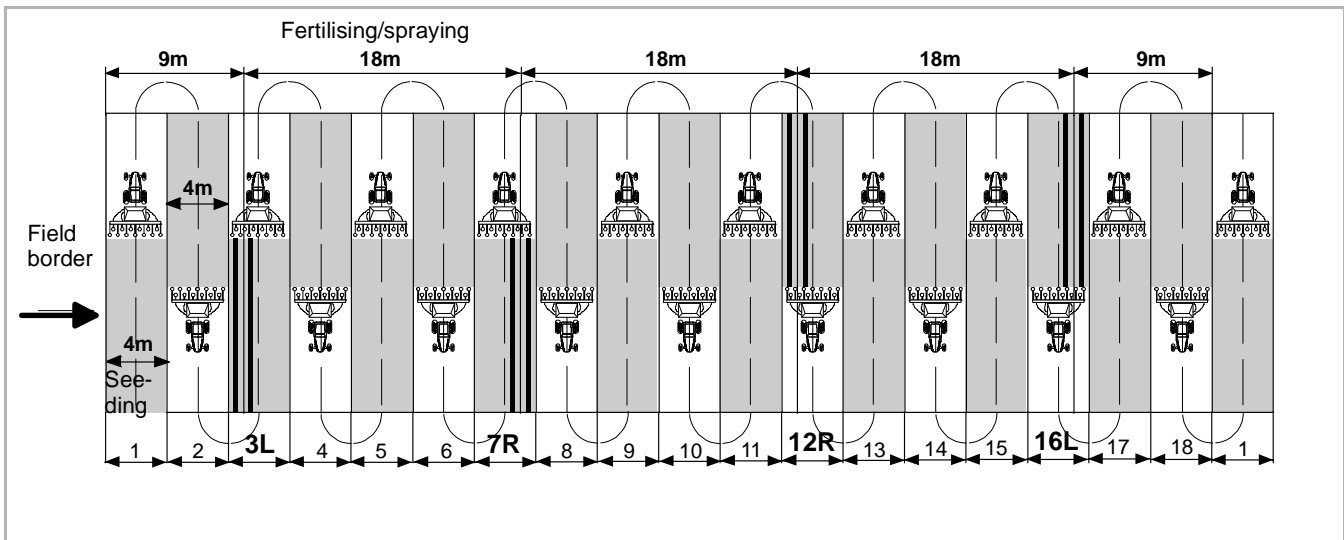

# Operation

## Select rhythm

The rhythm is dependent on the working width of the seeding machine and the spraying/fertilising unit. It can be:

- uneven
- even
- symmetrical  
(an "S" after the number indicates symmetry)
- a special rhythm.

The type of rhythm affects the set up of tramlines.



Once the tramline has been laid, the number on the display flashed as an extra visual indicator.

## Uneven rhythms

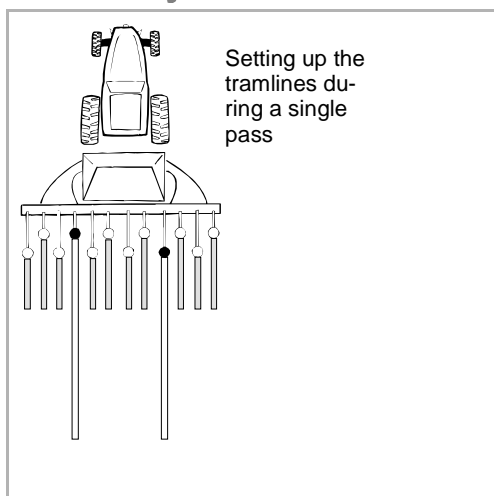

### 3, 5, 7, 9, 11

During a single pass, the tramline is always set up symmetrically. You can begin cultivation on the right or left side of the field.

## Even rhythms



Even rhythms are not possible with mechanical seeding machines.

The tramline is set up during two drive passes. The side of the field on which you must begin working depends on which side of your seeding machine (left or right) the shut-off valves are installed and on the rhythm you are using.

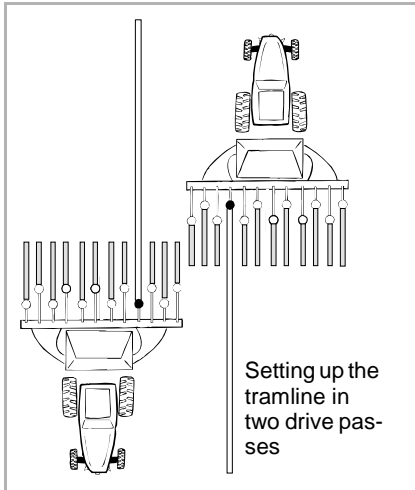

### 4, 8, 12

Begin on the side of the field on where the shutoff valves are installed.

### 6, 10, 14

Begin on the opposite side of the field to where the shutoff valves are installed.



### Select the correct side of the field

If you start on the wrong side of the field, the spraying/fertilising unit will not fit in the tramlines.



Setting up the tramlines in two drive passes means that the individual tracks cannot be set up as precisely as with a single pass. However, with even rhythms, the tramlines can be set up in a single pass. Your machinery must be set up for this at delivery.

Section »Symmetrical rhythms«, page 36.

## Symmetrical rhythms

### Example: 2S, 4S, 6S

Symmetrical rhythms compensate for the disadvantage of even rhythms, i.e. having to make two drive passes. Symmetrical rhythms are additionally identified by an "S". During the first drive at the start of the field you must turn off half the working width. The machinery must be set up for symmetrical rhythms at delivery.

- > Turn off half the working width and begin drilling on the corresponding side of the field. This pass is not counted in the tramline sequence.
- > Drill on the return pass using the complete working width. This is then pass "1" of the tramline sequence. Do not drive in the track marker track, but along the boundary of the surface cultivated in the first pass.



### Mind these peculiarities

If you fail to turn half the working width off during the initial pass or you do not drive along the boundary of the cultivated area on the return pass, the spraying/fertilising unit will not fit in the tramlines.

## Special rhythms

Special rhythms result from a poor ratio of seeding machine working width to spraying/fertilising unit working width. The machinery must be set up for special rhythms at delivery.

The side of the field on which you must begin working depends on the working width of both the seeding machine and the spraying/fertilising unit.



### Select the correct side of the field

If you start on the wrong side of the field, the spraying/fertilising unit will not fit in the tramlines.

## Removal

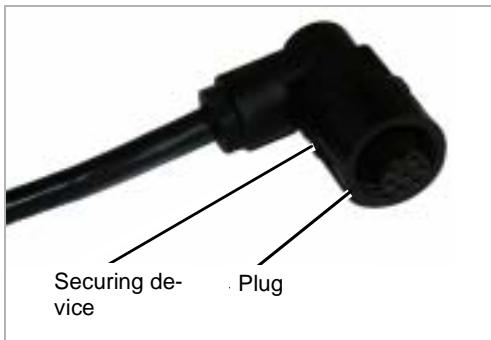

### Cable from job computer on seeding machine to terminal

- > Undo retainer
- > Remove plug from rear of terminal



### Power cable from job computer to tractor

- > Remove plug from socket on tractor
- > Slip on dust protection cap

## Storage











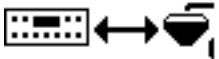

There should be no major fluctuations in temperature where the terminal is stored. The temperature range figures given in the technical data should be observed during storage as well. A dry and frost-free storage location is a prerequisite for a long working life of the device.

# Removing faults

Faults can often be easily and rapidly removed.  
Please check with the aid of the table whether you can remove the fault yourself before calling in the customer service.

Fault	Cause	Remedy
Implement cannot be switched on	The poles of the supply voltage are reversed	<ul style="list-style-type: none"> <li>• Have the polarity checked.</li> </ul>
	Power supply interrupted	<ul style="list-style-type: none"> <li>• Check the battery connecting cable</li> <li>• Check the terminals on the battery</li> <li>• Check fuses. If required: Replace the 30 A fuse</li> <li>• Connect up the power cable if the power supply was uncoupled</li> <li>• Check that the supply voltage is 12-14 V</li> </ul>
	System failure	Inform the Customer Service
No read out on the display	No power to display	Start the device from the beginning again Send the device back to the manufacturer if the display still shows nothing after the new start or if the display cannot be changed.
Terminal displays unexpected values	A mobile phone, radio equipment or radio antenna is operating too close to the device	Maintain a minimum distance of 1 metre
Speed is not displayed or is displayed too low	No pulse input	Enter pulse details
	Cable on the wheel sensor is defect or the wheel sensor is defect	Check cable and replace if necessary
	Terminal is faulty	Inform the Customer Service

## Removing faults

Fault	Cause	Remedy
<p>Alarms can be confirmed using the  button. The audible warning signal will stop and you can look for and correct the cause of the alarm without being disturbed.</p>		
 	<p>Insufficient voltage supply for the job computer.</p>	<p>Check the battery. Check the opto-sensor if the indicator shows "0".</p>
 	<p>Different software versions in main distributor and terminal</p>	<p>Inform the Customer Service</p>
 	<p>Very little seed in hopper.</p>	<p>Add seed.</p>
 	<p>The metering device is working with the wrong settings</p>	<p>Check setting</p>
	<p>The sensor on the metering device is defective</p>	<p>Replace the sensor</p>
	<p>The metering device does not turn</p>	<p>Check all parts of the drive for faults. Replace faulty parts.</p>
 	<p>The fan speed is too high or too low</p>	<p>Keep the fan speed within the target range.</p>
 	<p>The combination of working widths of the machine and the spraying/fertilising unit is not possible. Tramlines cannot be laid down.</p>	<p>Enter a suitable combination. If necessary, contact your dealer.</p>

# Disposal

---

Once it finally comes to the end of its working life, the device must be properly disposed of. Please observe the currently valid disposal regulations.

## **Plastic parts**

The plastic parts can be disposed of in the normal domestic rubbish according to specific national laws (residual waste).

## **Metal parts**

All components can be delivered to a metal recycling centre.

## **Electronics**

The PCB is to be treated as electronic scrap and must be disposed of as special waste. You can return the electronic part for disposal to the manufacturer if you are not able to locate a special waste collection centre near you. It will be disposed of in an environmentally favourable manner from there.

# The EC Conformity Declaration

## According to EC Directive 2004/108/EC

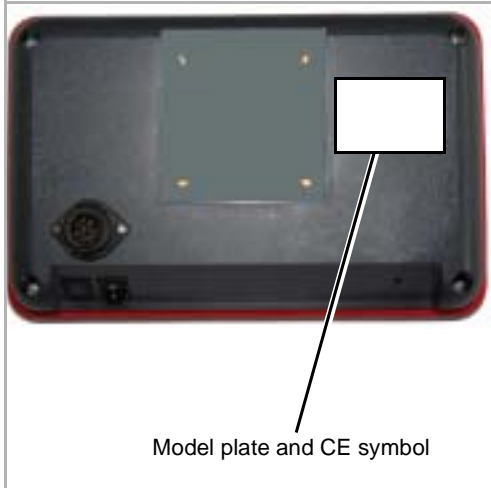

**Kverneland Group Soest GmbH**  
Coesterweg 42  
59494 Soest  
Germany

declares under its sole responsibility that the following product complies with EC Directive 2004/108/EC:

SIGNUS

Kverneland Group Soest GmbH  
Soest, 01.10.2008



Friedrich Pehle  
Managing Director

# Index

---

## A

Alarms 39

## B

Basic settings 14

## C

Conformity Declaration 41

Connecting up the machine 12

Connections 9

## D

Display 8

Disposal of the device 40

## E

Employer 4

## I

Instruction 4

## M

Mode of operation 10

## P

Pictogram 4

## R

Range of application 6

Removal 37

Removing faults 38

## S

Safety 5

Scope of delivery 11

Switch on 13

Symbols 4

## T

Technical data 10

The front side 8