

Date	Augustus 2022
Subject	<b>New generation boomguide pro</b>
Place	Kverneland Group Nieuw-Venep Hoofdweg 1278 2153 LR Nieuw-Venep The Netherlands
Details	Technical Service Manual

# Table of contents

---

<b>1. System overview</b>	<b>3</b>
<b>2. Electrical components and cables</b>	<b>4</b>
<b>3. Hydraulic system</b>	<b>15</b>
<b>4. Mechanical settings</b>	<b>19</b>
<b>5. Software screens</b>	<b>27</b>
<b>6. Ergodrive</b>	<b>46</b>
<b>7. Hydraulic retune</b>	<b>48</b>
<b>8. Automatic set-up</b>	<b>50</b>
<b>9. How to</b>	<b>55</b>
<b>10. Setup: Pushtest, Valves, Sensors</b>	<b>56</b>
<b>11. Flashing</b>	<b>59</b>
<b>12. Trouble shooting flowchart</b>	<b>60</b>
<b>13. Troube shooting</b>	<b>65</b>

# 1. System overview

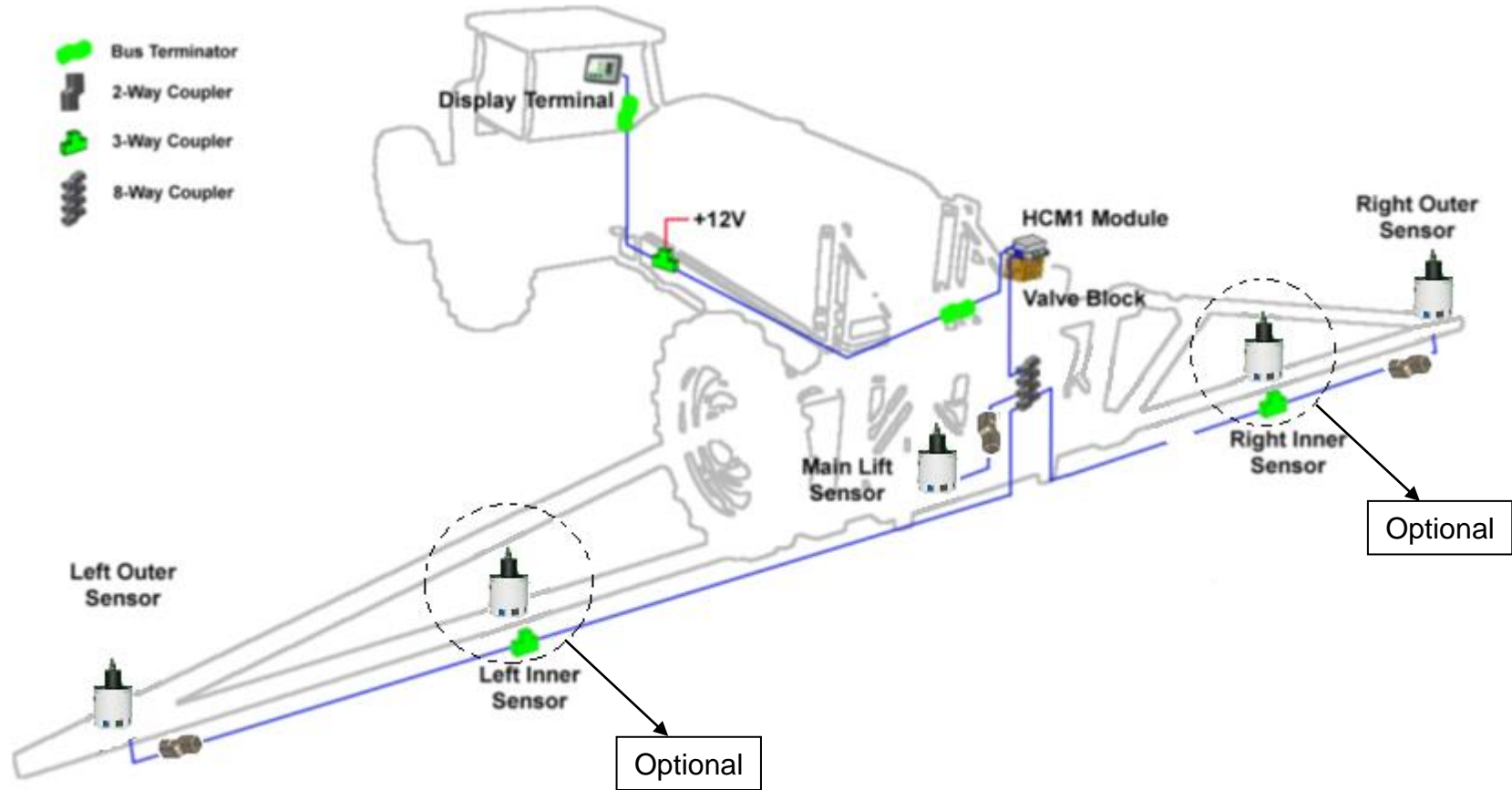

## 2. Electrical components and cables

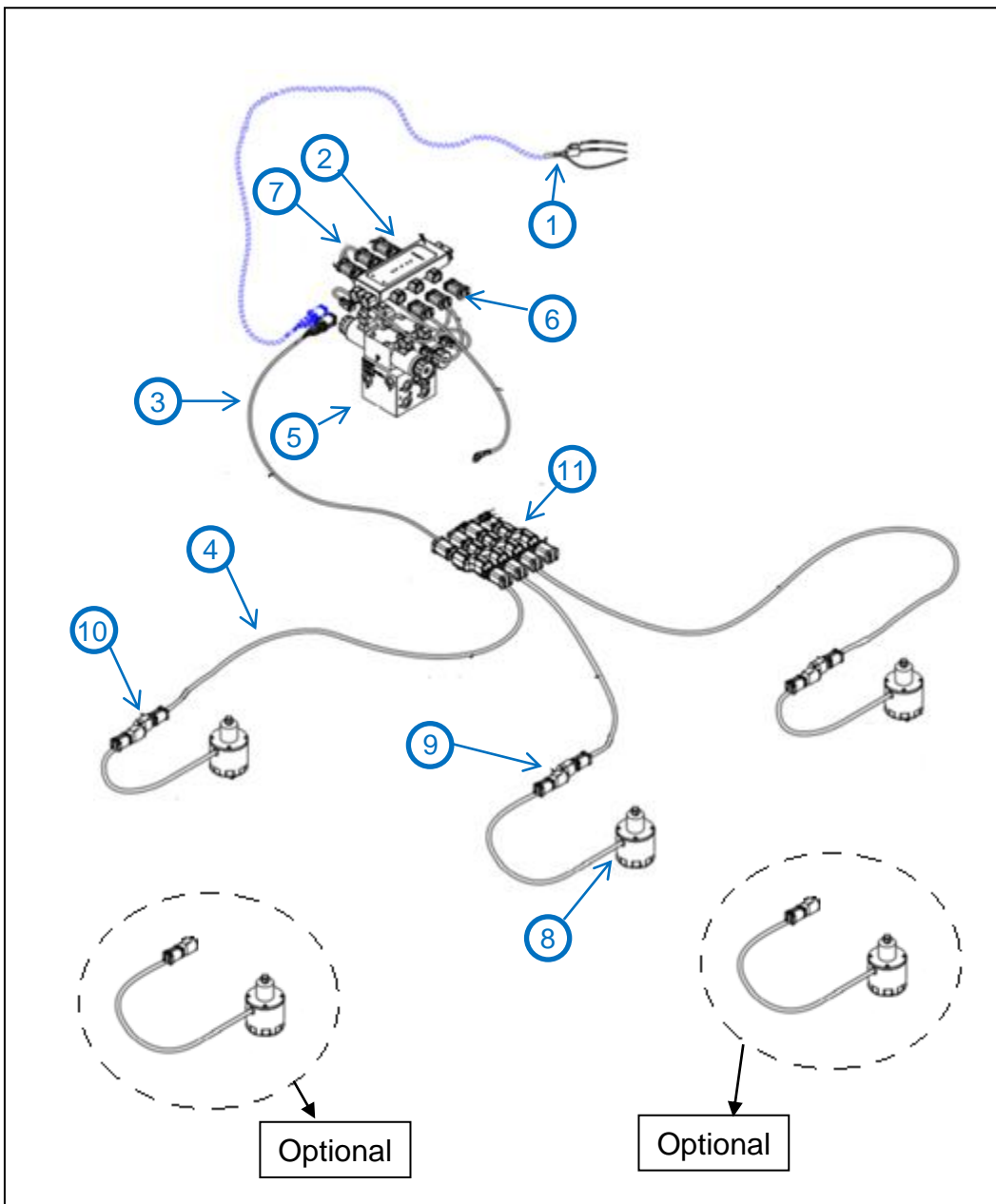

Item	Description
1	Display/power cable
2	HCM1 module
3	CAN connection cable (14 AWG)
4	CAN connection cable (18 AWG)
5	Proportional valve block
6	4 pin plug
7	Valve cable 4 pin to 2 pin
8	Height sensor
9	2 way coupler
10	2 way coupler with CANbus terminator (end resistance)
11	8 way coupler

## 2. Electrical components and cables

### Part list

Item	Part number	Name	Quantity
1	A148729678	HCM1 module	1
2	A148729530	Height sensor	3 (*5)
3	A148730878	Power/Display cable	1
4	A148730478	Valve cable 4 pin to 2 pin	2
5	A148730378	Cable temperature probe	1
6	A148729878	4 pin plug	2
7	VNB4885878	6 pin plug	2
8	A148729778	12 pin plug	1
9	A148730778	Set mounting clips HCM1	1
10	TBD	Aluminium boom plate	2 (*4)
11	VNB4680678	Proportional valve block	1
12	VNB4680078	2 way coupler	1
13	VNB4885778	2 way coupler with CANbus terminator	2
14	VNB4679578	3 way coupler	(*2)
15	VNB4886078	8 way coupler	1
16	Depends on machine	CAN connection cable (14 AWG) (1m)	1
17	Depends on machine	CAN connection cable (14 AWG) (3m)	1
18	Depends on machine	CAN connection cable (18 AWG) (15/20m)	2 (*4)

\* Enkel bij machines met 5 hoogtesensoren

## 2. Electrical components and cables

### PCB connections iXspray sprayers

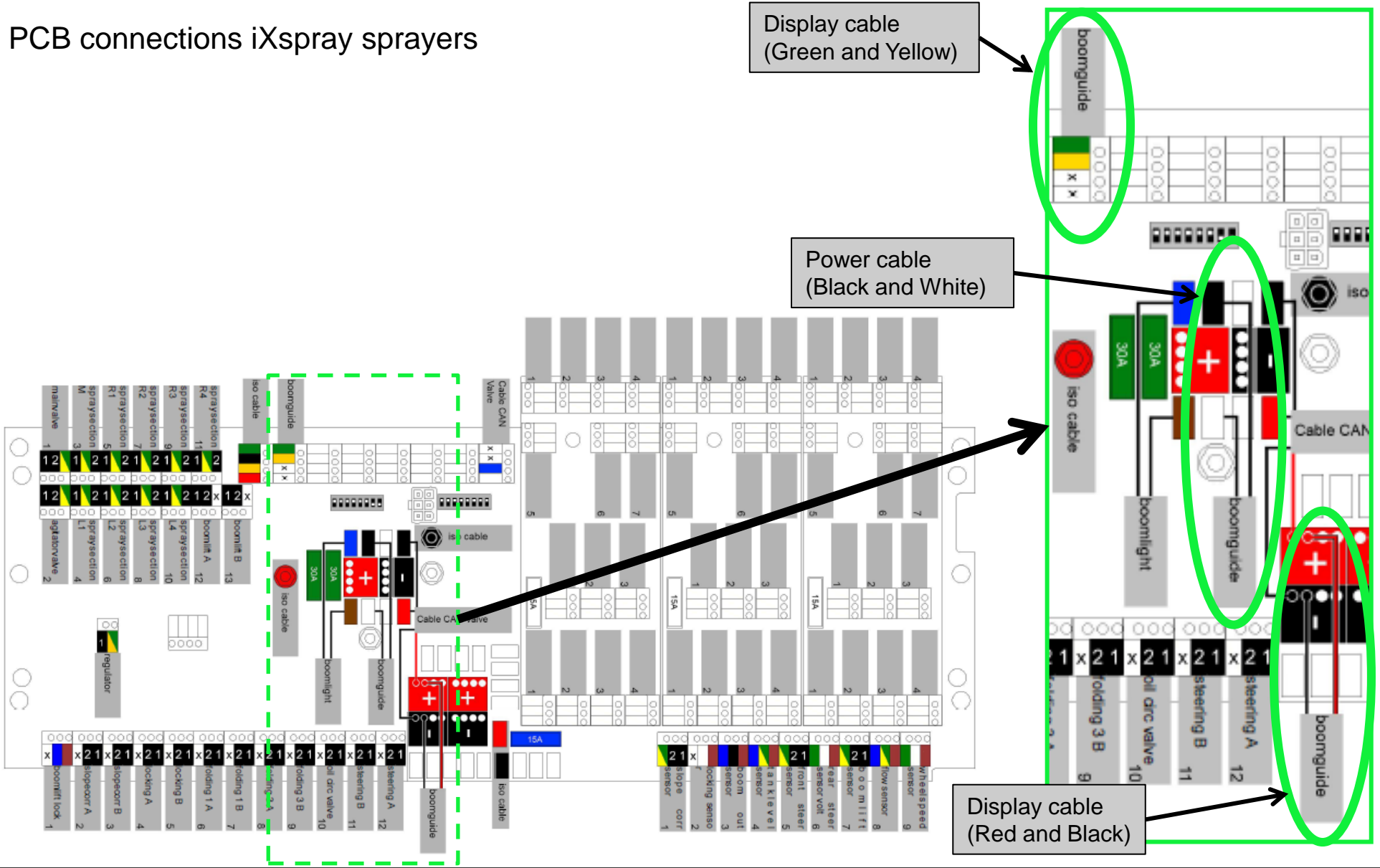

## 2. Electrical components and cables

### Power/Display cable

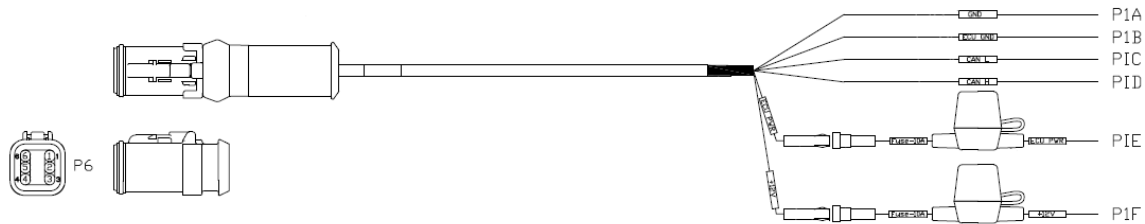

To protect the system, the power cables are equipped with a fuse (15A)

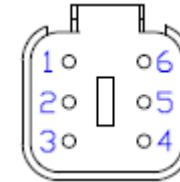

Pin	Function
1	Switch ground
2	ECU_Ground
3	CAN Low
4	CAN High
5	ECU_Power
6	Switch Power

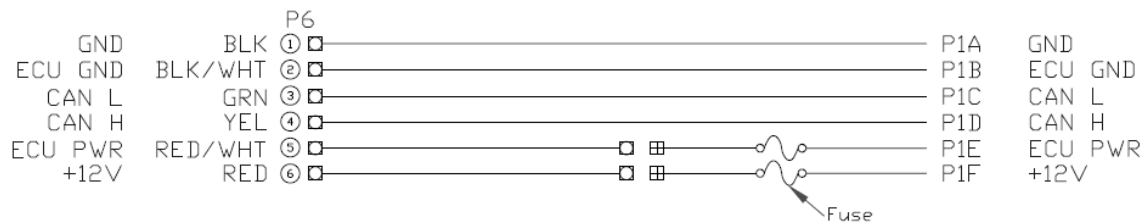

## 2. Electrical components and cables

### CAN connection cables (14+18 AWG)

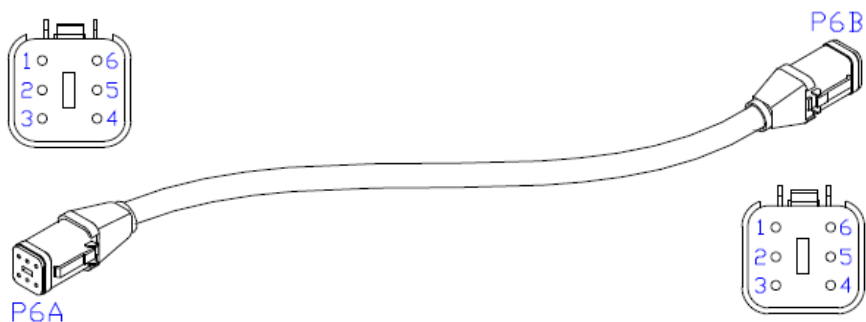

### 4 pin to 2 pin valve cable

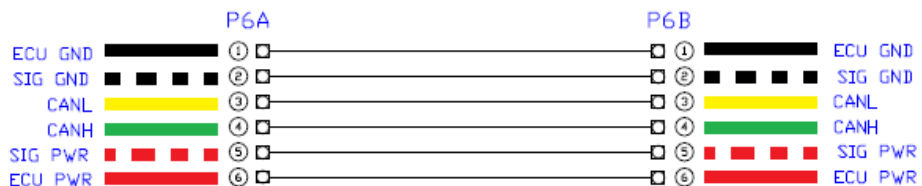
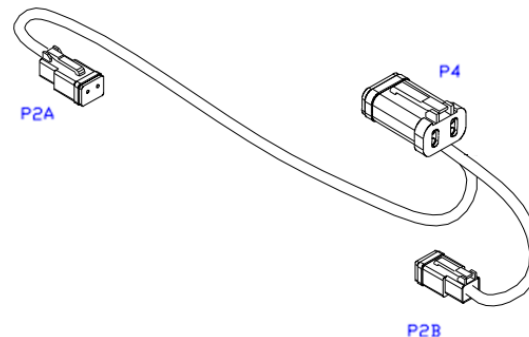

The 14 AWG CAN connection cables has a thicker (12 volt ECU power) wire than the 18 AWG CAN connection cable.

#### Item C05: 43210-20 - CBL, NETWORK 18 AWG 20M

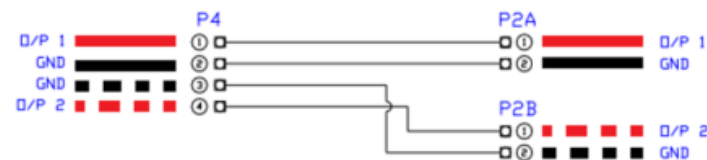
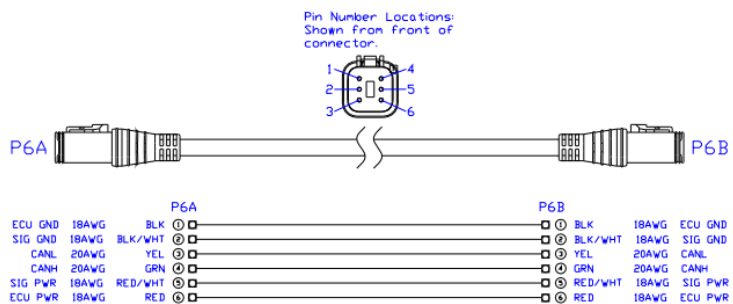

#### 8.4. Item C10: 50130-01 - CBL, VLV 4PIN TO 2PIN DT

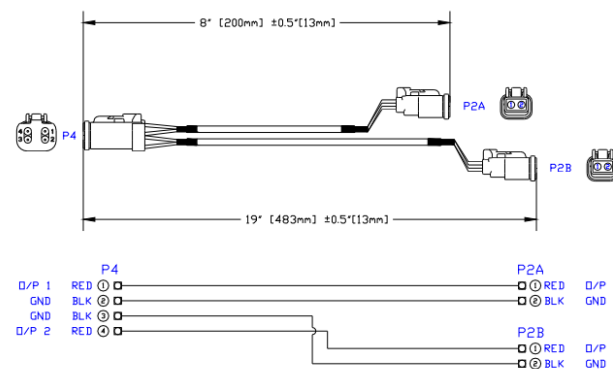

## 2. Electrical components and cables

### 8-way coupler

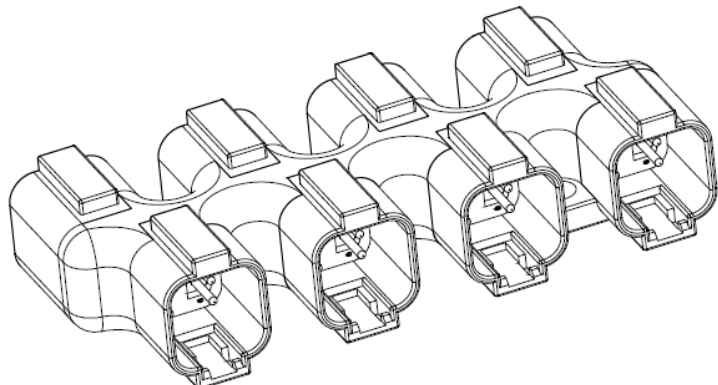
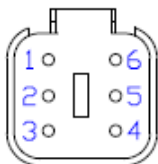

### 2 way coupler (black)

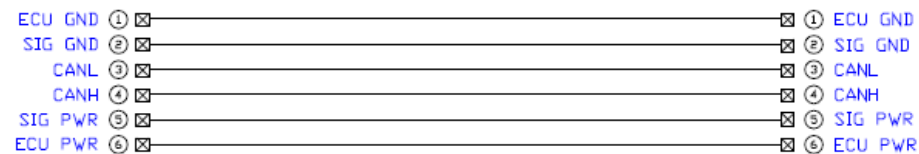
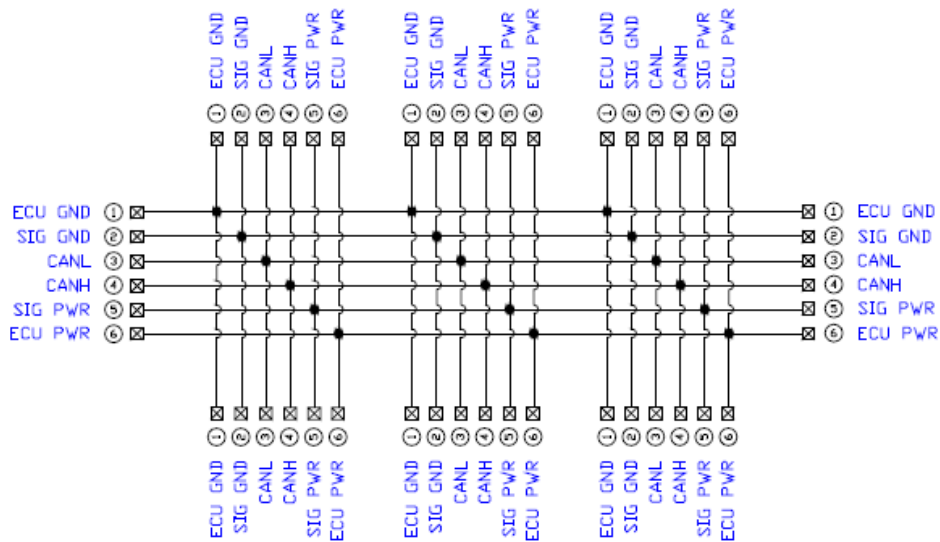
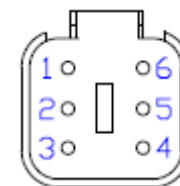
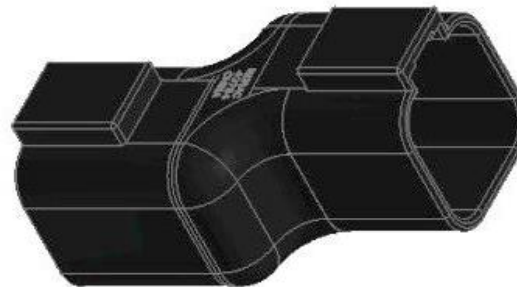

The 2 way coupler (black) is used at the middle height sensor (boomguide basic/pro active).

## 2. Electrical components and cables

### 2 way coupler with terminator (white)

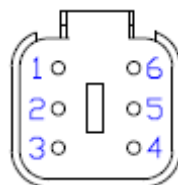

### 3 way coupler with terminator

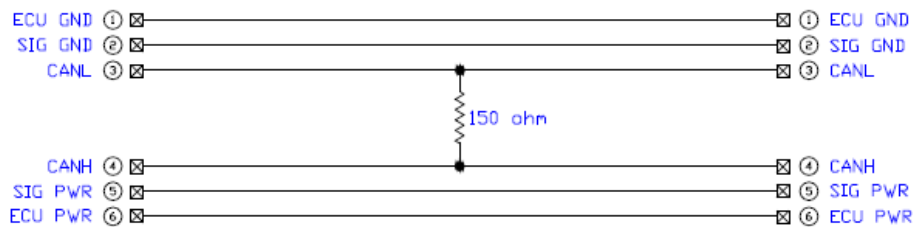
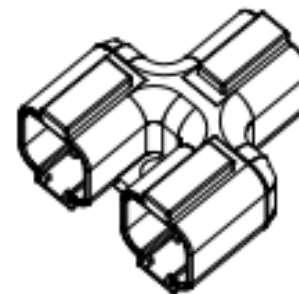

The 2 way coupler (white) is used at the outer height sensors (on the left and right side boom).

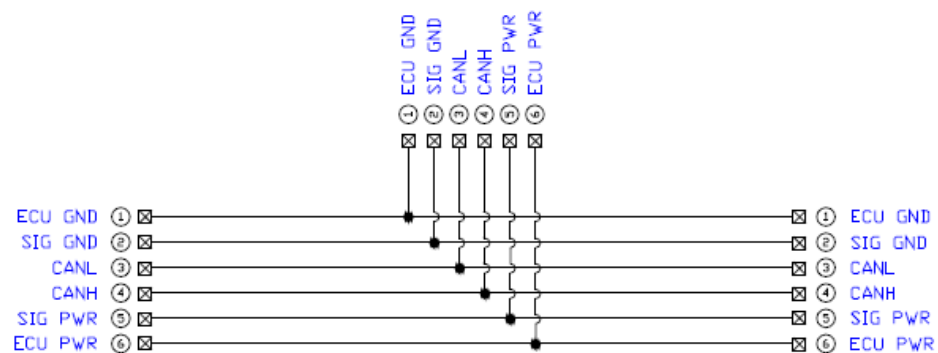

The 3 way coupler is used at the outer height sensors on the left and right side boom. (Only when 5 sensors are used).

## 2. Electrical components and cables

### Valve module

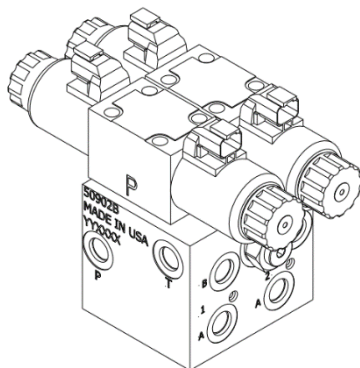

The valve module is sending signals to the proportional valves through the valve cables.

The HCM1 module is fitted with the mounting clips on top of the hydraulic valve block.

### HCM1 module

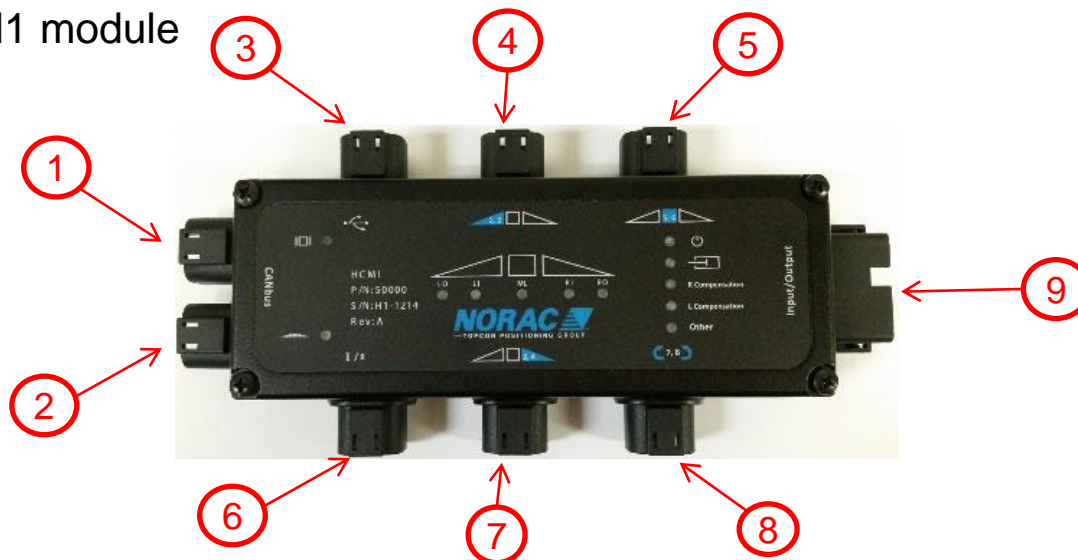

The boomguide software is stored in the HCM1 module.

The licence code is on the backside of the HCM1 module.

There are 9 ports on the HCM1 module.

1. Display/power port for communication with the terminal.
2. Communication port for communication with boomguide components.
3. USB connection port to flash software (only possible with a flat USB-driver).
4. Left boom height sensor communication to valve module.
5. Not connected on Kverneland machines.
6. Temperature probe connection.
7. Right boom height sensor communication to valve module.
8. Not connected on boomguide pro.
9. Not connected on Kverneland machines.

## 2. Electrical components and cables



LED	LED State	Description
[A] Power	Solid Green	Ok - Module is powered up
	Flashing Green	Low supply voltage
	Solid Red	Module failure
	Flashing Red	Module failure
	Off	Module failure or no power to module
[B] Display Bus or [C] Boom Bus	Solid Green	Ok - Communicating
	Flashing Green	Number of modules connected (30 seconds on startup)
	Flashing Orange	Programming
	Solid Red	Not communicating
	Flashing Red	Bus errors detected (reset on power up)
[D] Hydraulics	Solid Green	Ok
	Solid Orange	Temperature probe is not connected Oil temperature above the normal working range
[E] Sensors	Solid Green	Ok - Sensor connected
	Flashing Green	Programming
	Flashing Orange	No sensor readings (No Data)
	Solid Red	A sensor has been mapped to this location, and it is not communicating (No Communication)
	Flashing Red	Stuck in programming mode
	Off	No sensor is mapped to this location
[F] Other	Solid Green	USB drive is connected
	Flashing Green	Reading from USB drive

## 2. Electrical components and cables

### Height sensor (ultrasonic)

Foam protection

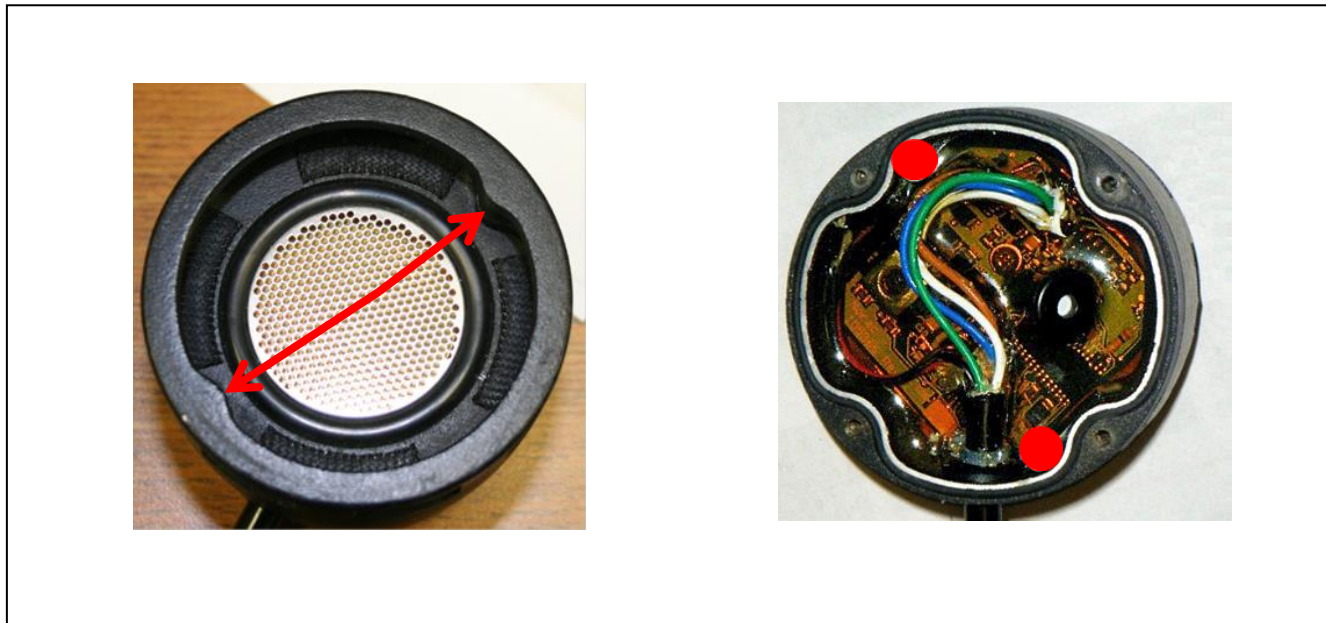

Inside the height sensor there is a foam protection. This protection is important, it filters the signals to a stable signal.

Filters should be clean/ free of mud/dust at all times.

The height sensors have got 2 air breather holes. It is important that these holes are open and free of dirt.

When the air breather holes are blocked, the sensor will give unstable data or no data at all.

The holes can be cleaned by opening the top part of the height sensor (4 screws).

The 2 air holes can be cleaned using a small part of iron or air (2 red dots on picture above).

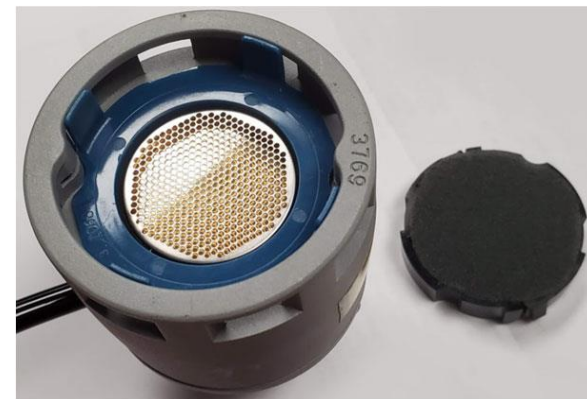

## 2. Electrical components and cables

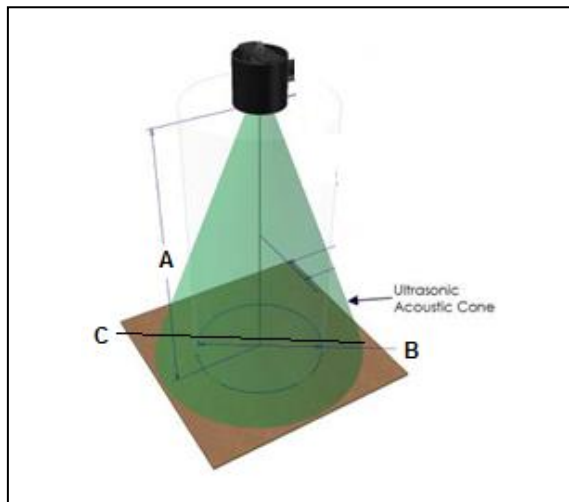

### Height sensor (ultrasonic)



In the lowest position of the boom, the sensor must be 23 cm or more from the ground/top of crop (A).

The centerline of the acoustic cone should be approximately vertical at normal operating heights (A).

The bottom of the sensor must be at least 23 cm in front of the spray nozzles and boomstructure (B). (This does not apply for the main lift sensor).

The diameter of the reading width of the sensor is a proximally 60 cm (C).

Roll sensors are now integrated in the height sensors.

The serial number of the sensor can be found on the bottom of the sensor (1).

When build in the sprayer, the height sensor connection wire needs to point directly in a straight line to the direction of the boom (2).

When replacing a height sensor, first disconnect the old sensor. Then restart the machine, then connect the new sensor. It's not necessary to flash or reinstall the control module.

If it's a 5 sensor machine, only the roll sensors within the 2<sup>nd</sup> and 4<sup>th</sup> height sensor is active (so the inner sensors).

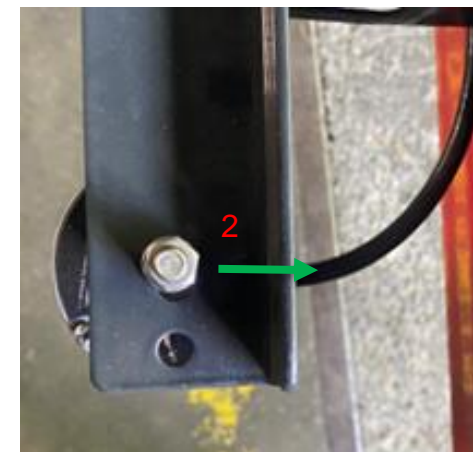

### 3. Hydraulic system

#### Hydraulic system tractor



- The hydraulic system of the tractor has to be set to 35 liters per minute.
- The hydraulic system of the tractor must have a minimum pressure of 180 Bar.
- The tractor needs a good oil cooling system (oil cooler).
- When there is a change of tractors, the hydraulics of the boomguide system has to be retuned.

#### Wing speed

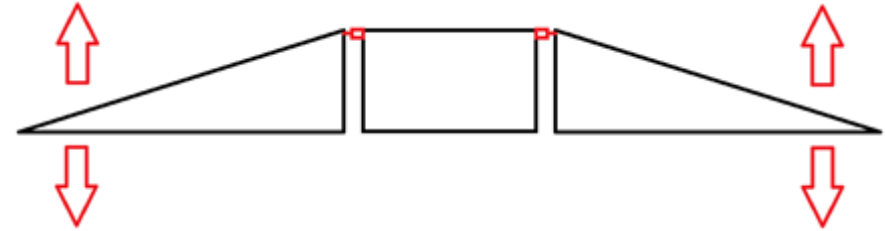

Between 75 and 100 cm per second

Between 75 and 100 cm per second

To ensure that the machine will perform in a good way, it is important that the hydraulic speed of the wings down is set right. Only the wing speed down contains a restrictor and can be adjusted.

The adjustment has to be done under normal oil temperature and RPM.

Check chapter 12.3 how to set the maximum wing speed down.

#### HC boom

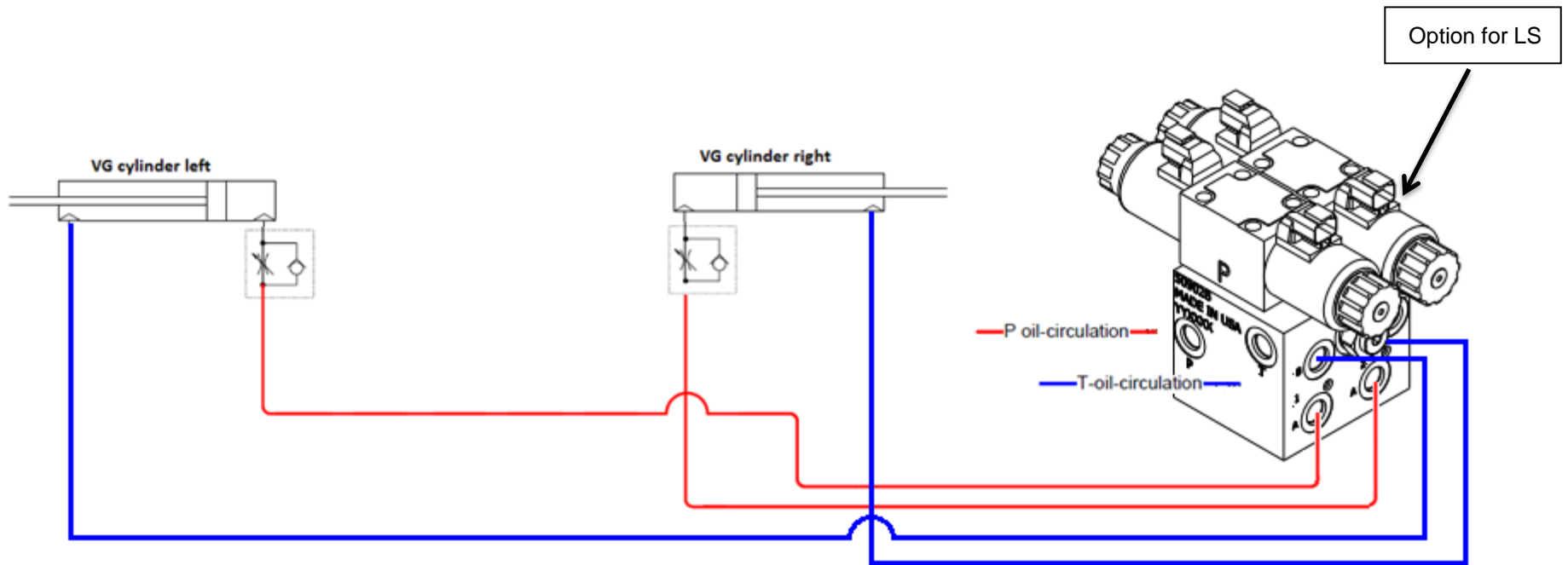

The hydraulic boomguide pro system on a HC boom (double acting VG cylinders).

#### HSS/HSA boom

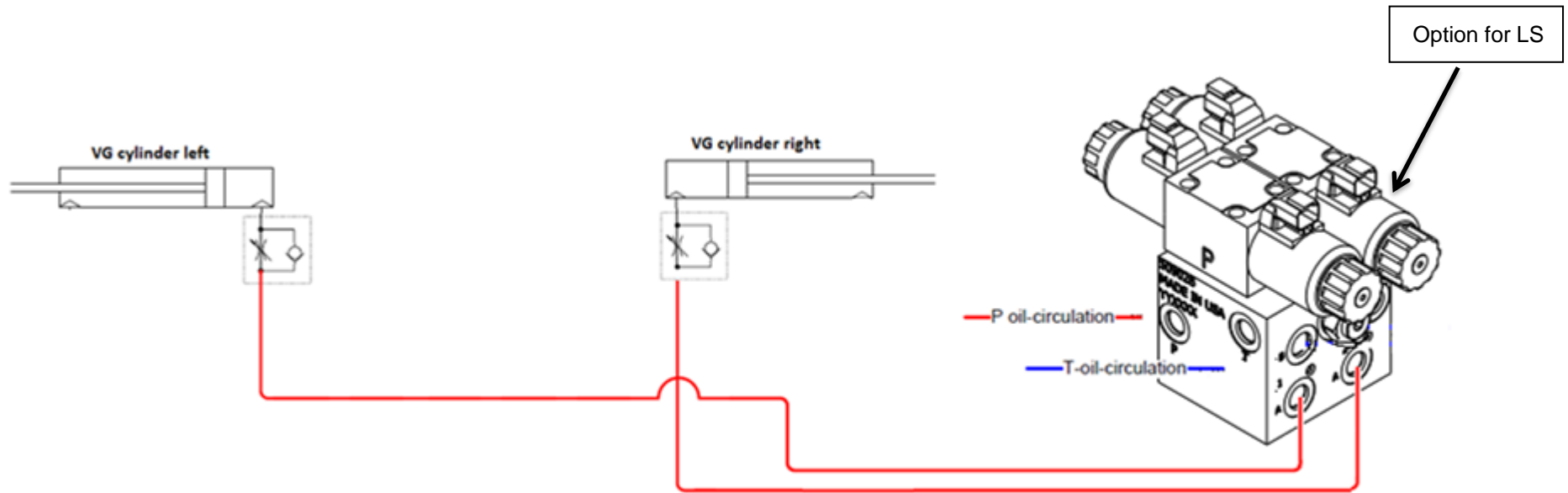

The hydraulic boomguide pro system on a HSS/HSA boom (single acting VG cylinders).

## Hydraulic valve block (proportional)

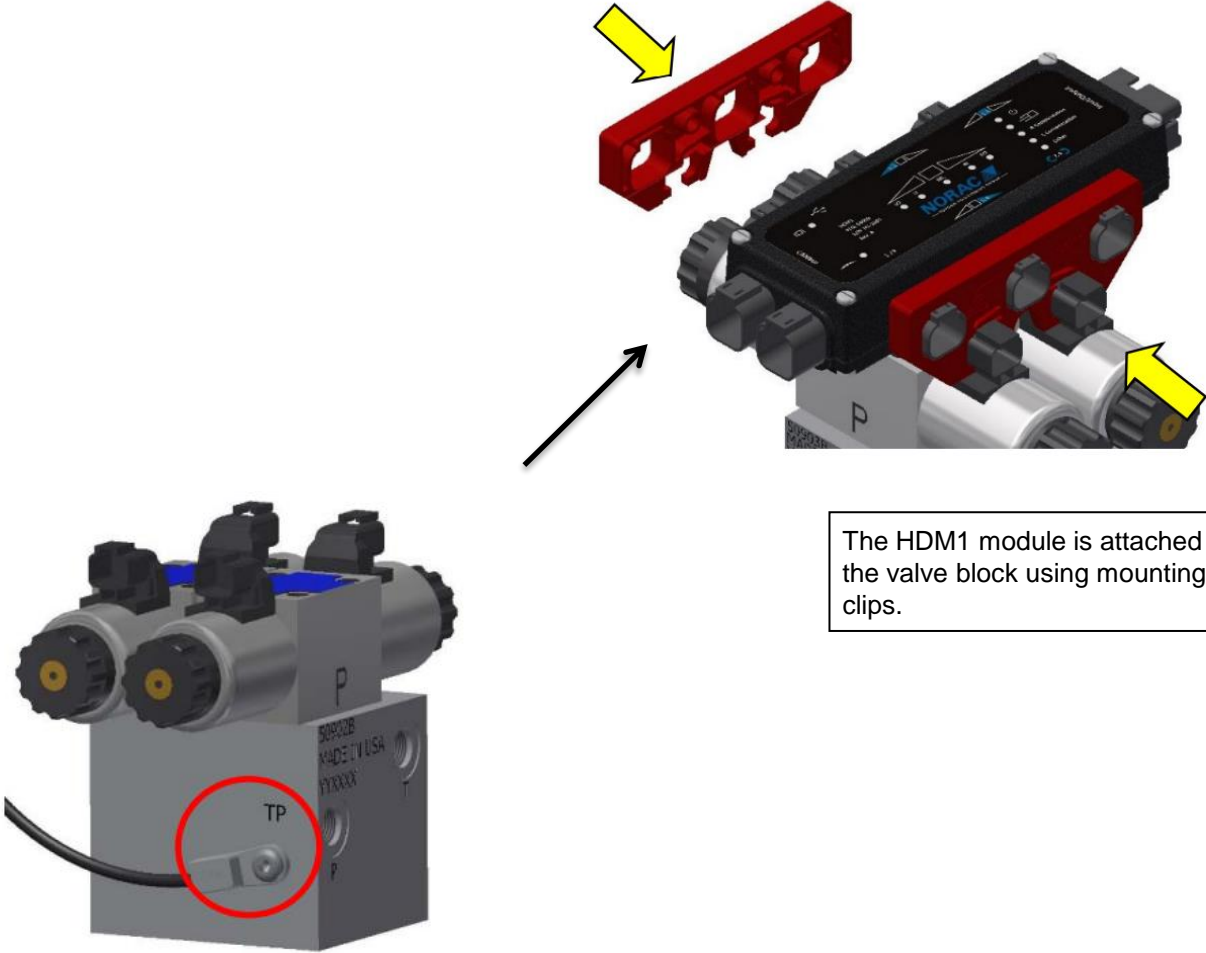

The temperature probe is mounted to the side of the valve block

The HDM1 module is attached to the valve block using mounting clips.

## 4. Mechanical settings

### Free play wearing plates between rollers and wearing plates

Between the rollers and wearing plates should be 1 mm free play (The free play is always on 1 side of the roller).

If there is more than 1 mm free play, the horizontal movement of the sprayboom is too much. Remove filling washers (1 mm) to reduce the free play.

If there is less than 1 mm free play, there is too much friction in the middle frame. Add filling washers (1mm) to create 1 mm free play.

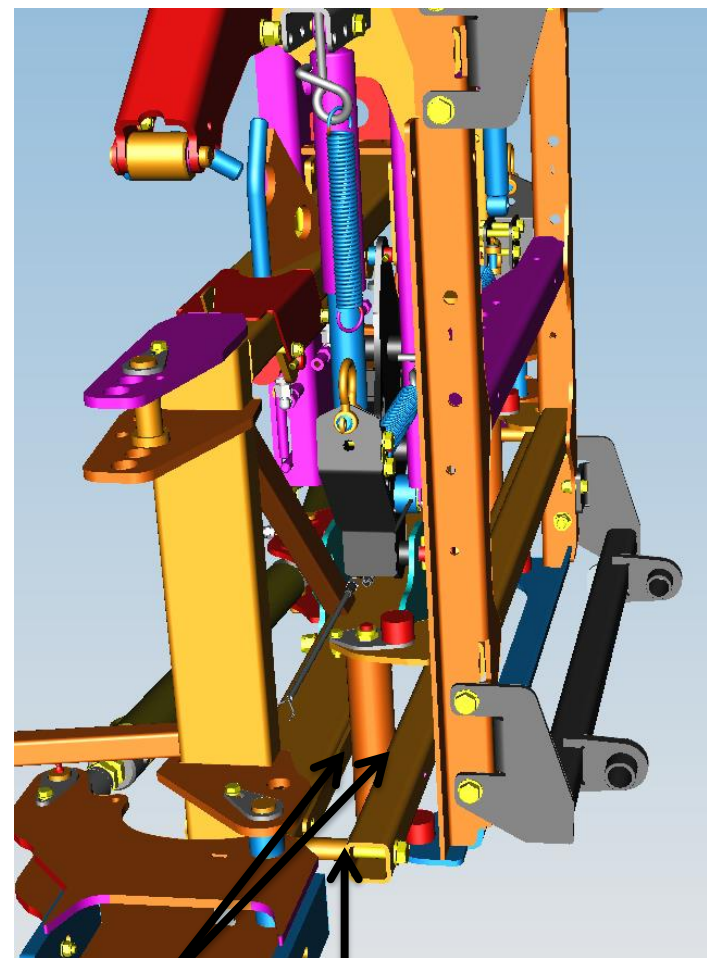

1 mm free play

Add or remove filling washer



# 4. Mechanical settings

Different types of absorbers and springs

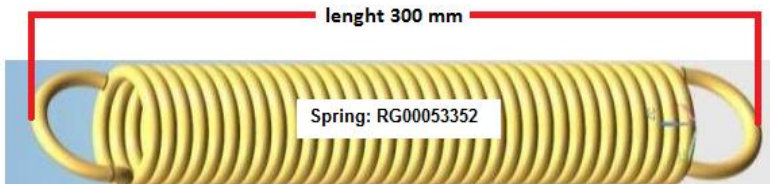
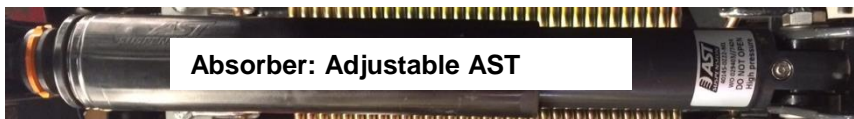

Diameter: 50 mm



Diameter: 28 mm



Diameter: 26 mm



Diameter: 37 mm

# 4. Mechanical settings

## iXtrack T/iXterB Settings HC 18-21 m Boomguide pro

Nr	Part	Type	Setting
1	Side springs	VNB3682493 (heavy)	Length 280 mm
2	Side absorbers	Adjustable Koni	Completely closed
3	Pendulum springs	VNB3682493 (heavy)	Length 280 mm
4	Buffers	Red diameter 80 mm	Small pre tension on bolts
5	Hill position pin	200 mm	Mounted/in
6	Flatland pin	250 mm	Stored/out

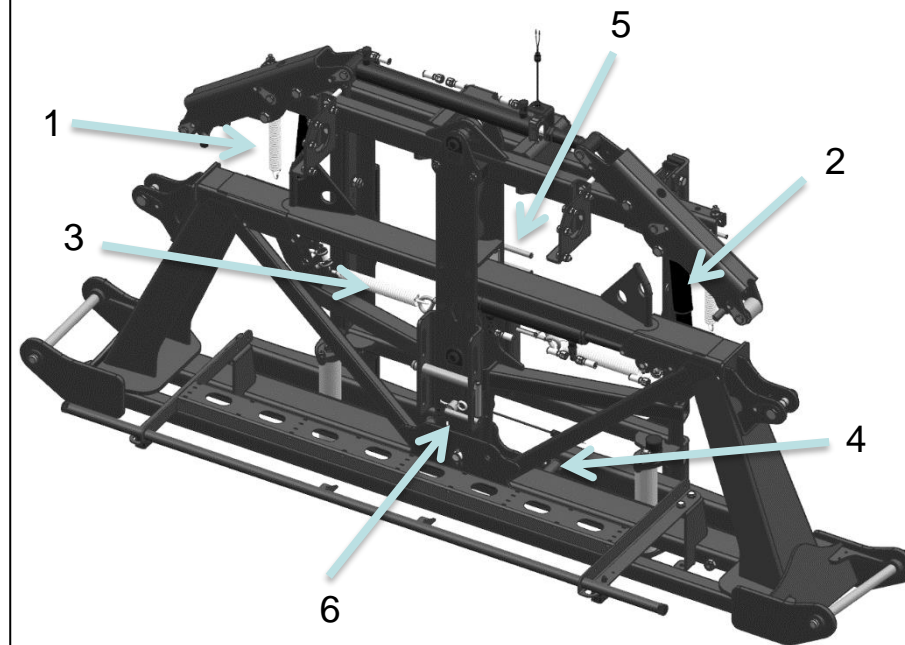

**6. Flatland pin**

**5. Hill position pin**

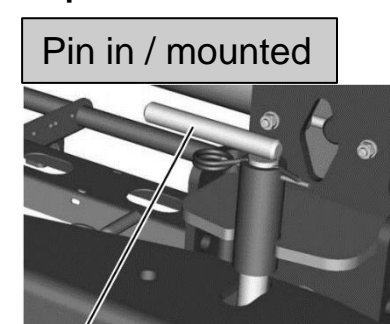
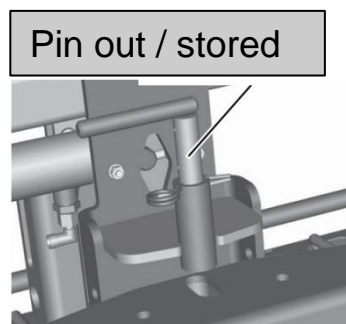
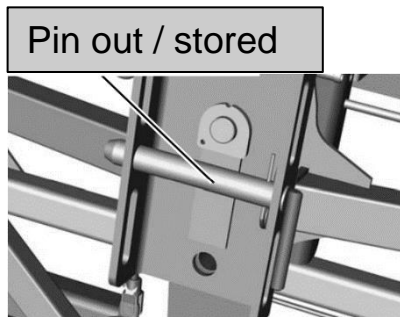
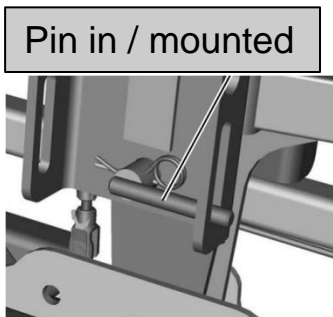

# 4. Mechanical settings

## iXtrack T/iXterB Settings HC 24 m Boomguide pro

Nr	Part	Type	Setting
1	Side springs	VNB3682493 (heavy)	Length 280 mm
2	Side absorbers	Adjustable Koni	Completely closed
3	Pendulum springs	VNB3682493 (heavy)	Length 280 mm
4	Pendulum absorbers	Black	Not adjustable
5	Hill position pin	200 mm	Mounted/in
6	Flatland pin	250 mm	Stored/out

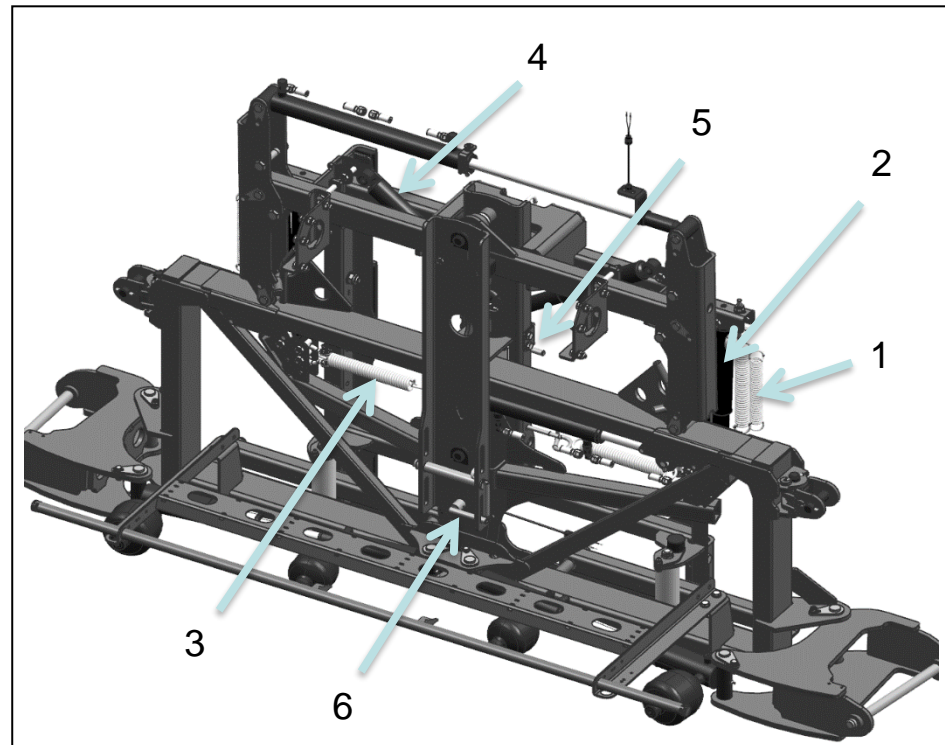

**6. Flatland pin**

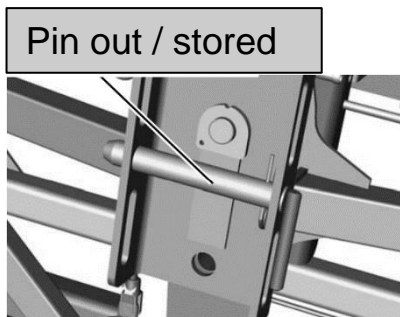
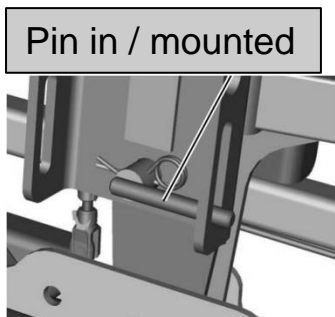

**5. Hill position pin**

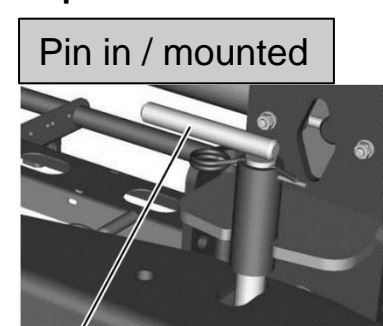
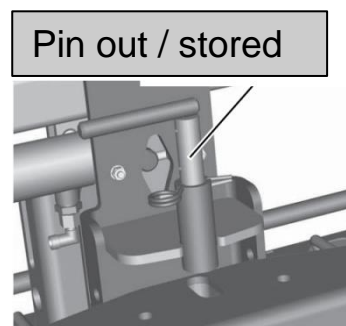

# 4. Mechanical settings

## iXtrack T/iXterB

### Settings HC 27-30 m Boomguide pro

Nr	Part	Type	Setting
1	Side springs	VNB3682493 (heavy)	Length 280 mm
2	Side absorbers	AST shock absorber	Adjustment position 7
3	Pendulum springs	VNB3682493 (heavy)	Length 280 mm
4	Pendulum absorbers	Black	Not adjustable
5	Hill position pin	200 mm	Mounted/in
6	Flatland pin	250 mm	Stored/out

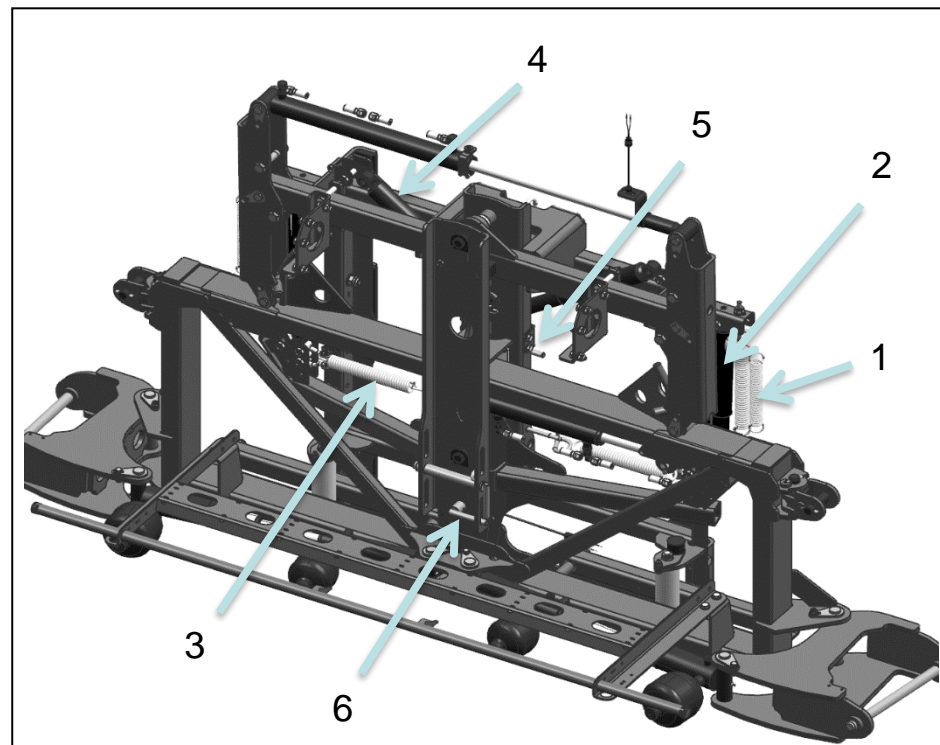

**6. Flatland pin**

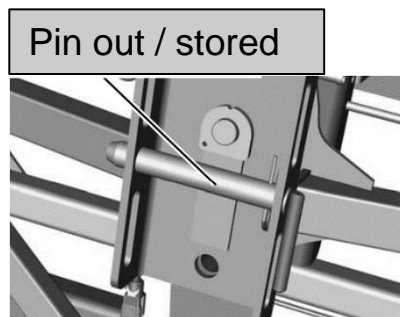
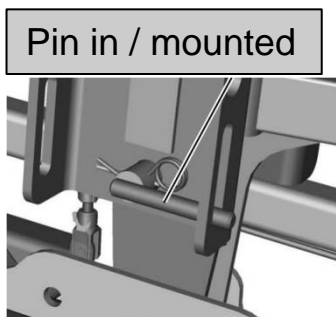

**5. Hill position pin**

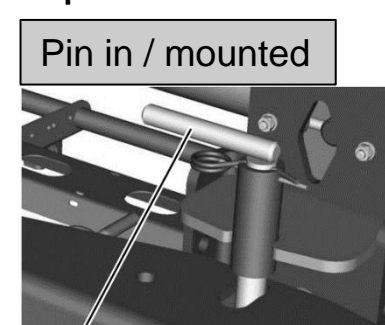
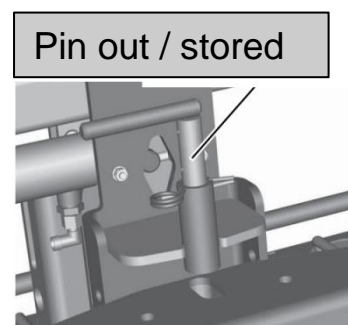

# 4. Mechanical settings

## iXtrack T Settings HSS 18-24 Boomguide pro

Nr	Part	Type	Setting
1	Side springs	VNB3682493 (heavy)	Length 280 mm
2	Side absorbers	Adjustable Koni	Completely closed
3	Pendulum springs	VNB3682493 (heavy)	Length 280 mm
4	Hill position pin	200 mm	Mounted/in
5	Flatland pin	250 mm	Stored/out

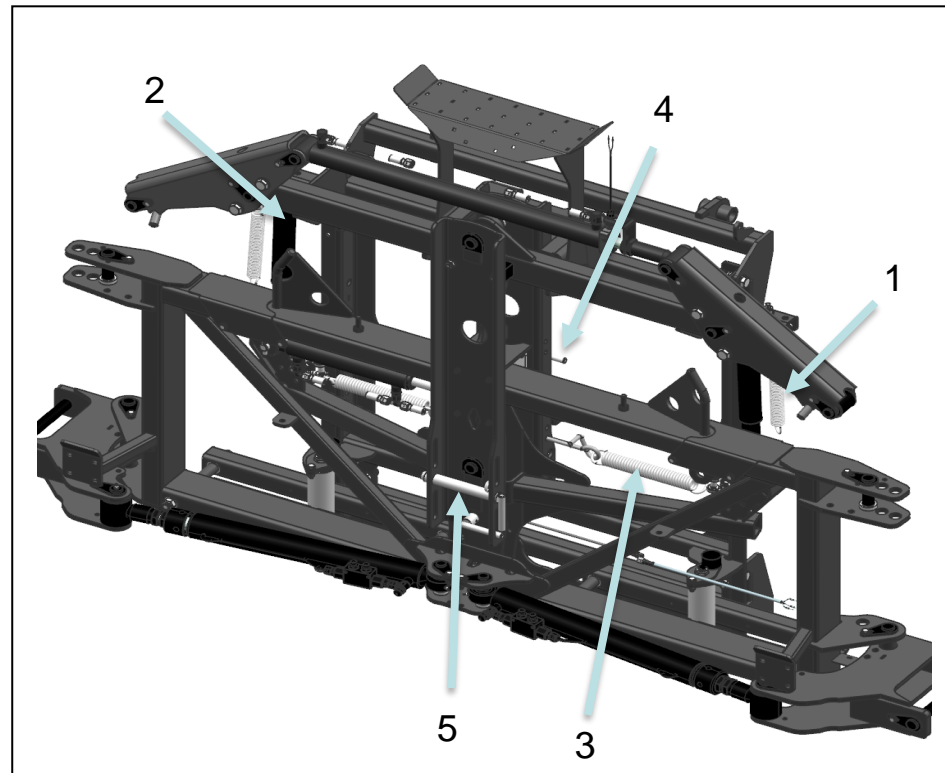

**5. Flatland pin**

**4. Hill position pin**

Pin in / mounted

Pin out / stored

Pin out / stored

Pin in / mounted

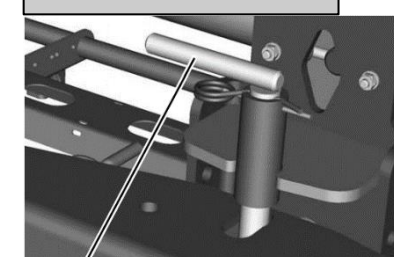
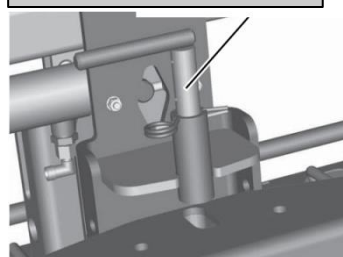
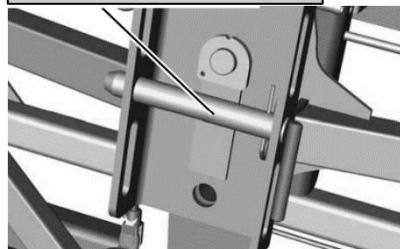
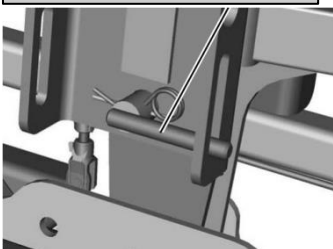

## 4. Mechanical settings

### iXtrack T Settings HSS 27-30 m 3PF Boomguide pro

Nr	Part	Type	Setting
1	Side springs	VNB3682493 (heavy)	Length 280 mm
2	Side absorbers	AST shock absorber	Adjustment position 5
3	Pendulum springs	VNB3682493 (heavy)	Length 300 mm
4	Pendulum absorbers	Black	Not adjustable
5	Hill position pin	200 mm	Mounted/in
6	Flatland pin	250 mm	Stored/out
7	Buffer frontside	Black diameter 63	Small tension on bolts
8	Buffer backside	Black diameter 63	Small tension on bolts

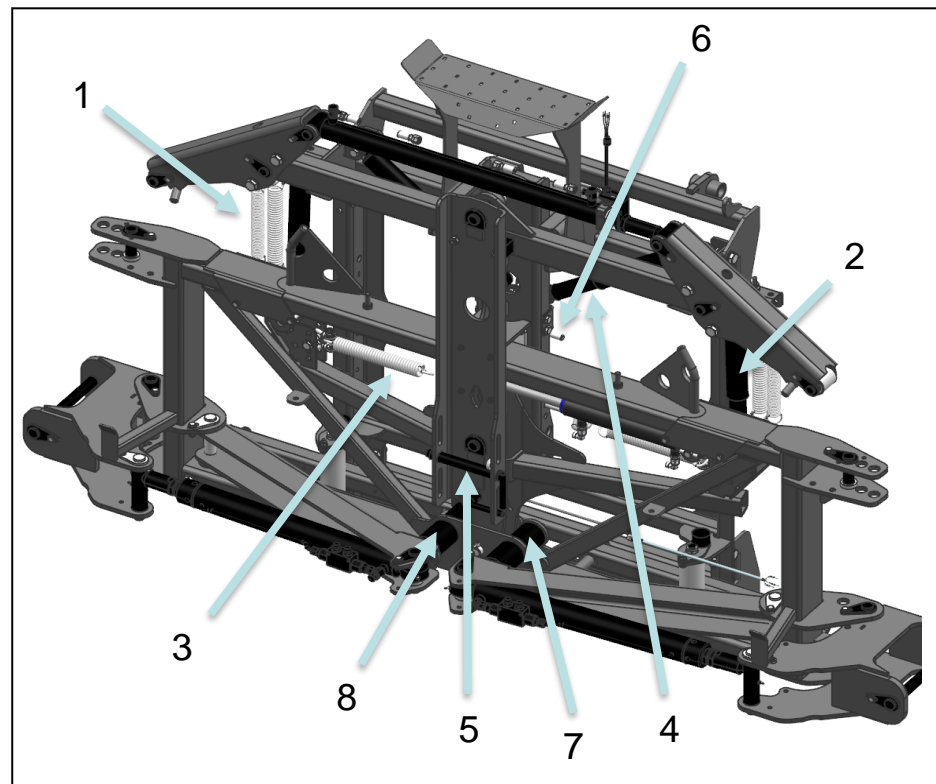

#### 6. Flatland pin

Pin in / mounted

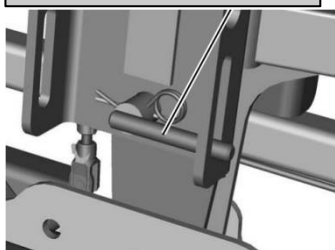

Pin out / stored

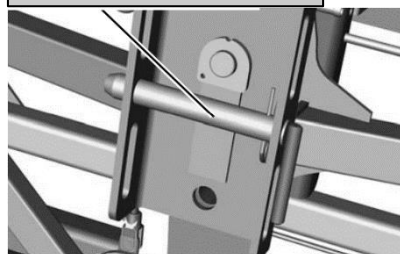

#### 5. Hill position pin

Pin out / stored

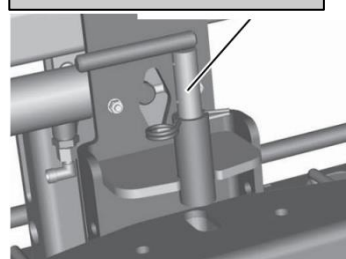

Pin in / mounted

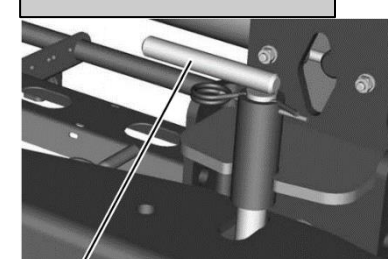

# 4. Mechanical settings

## iXtrack T Settings HSS 27-30 m 2PF + HSA 21-33 m Boomguide pro

Nr	Part	Type	Setting
1	Side springs	RG00053352	Length 310 mm
2	Side absorbers (inside)	AST shock absorber	Adjustment position 7
3	Side absorbers (outside)	Not mounted	
4	Pendulum absorbers	Black	Not adjustable
5	Balancing pin	200 mm	Mounted/in
6	Pendulum springs	VNB3682593	Length 280 mm
7	Buffer frontside	Black diameter 80	Small tension on bolts
8	Buffer backside	Black diameter 80	Small tension on bolts

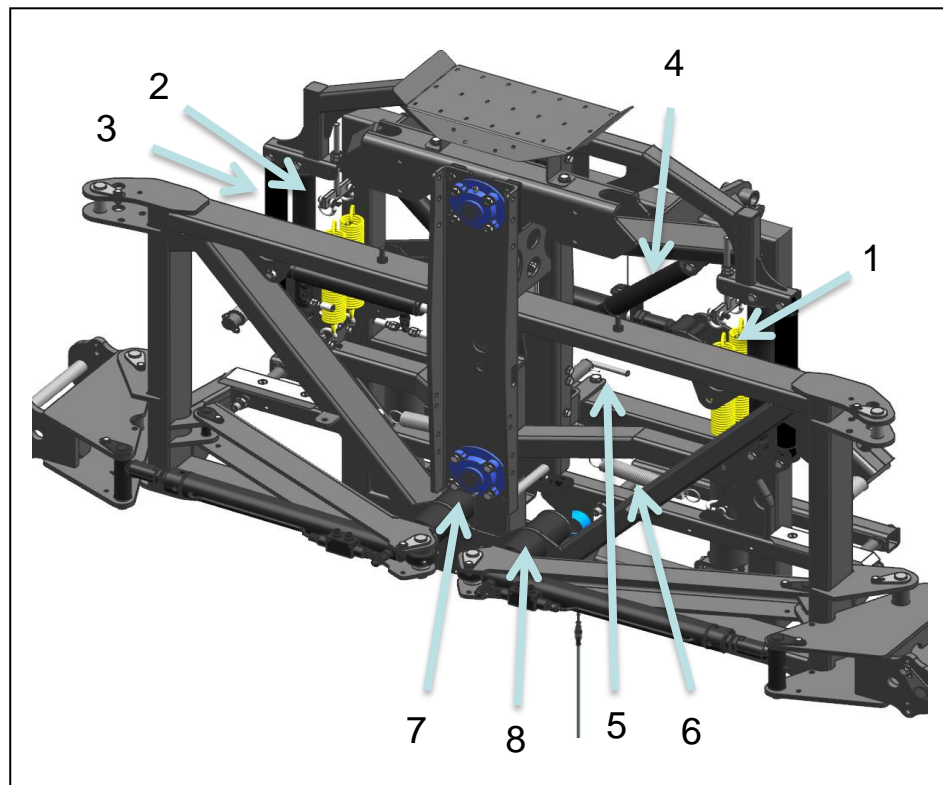

### 6. Flatland pin

Pin in / mounted

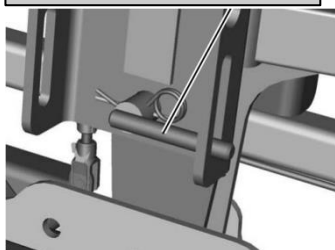

Pin out / stored

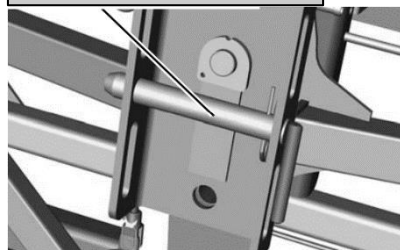

### 5. Hill position pin

Pin out / stored

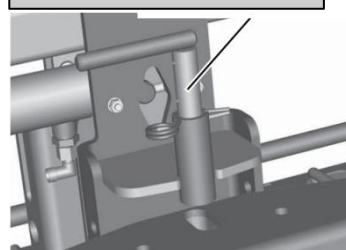

Pin in / mounted

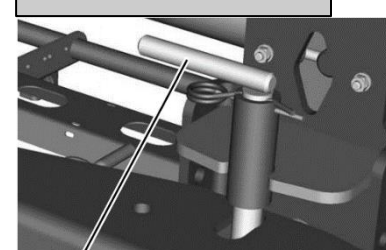

## 5. Software screens

### Flashing

USB connector



LED light

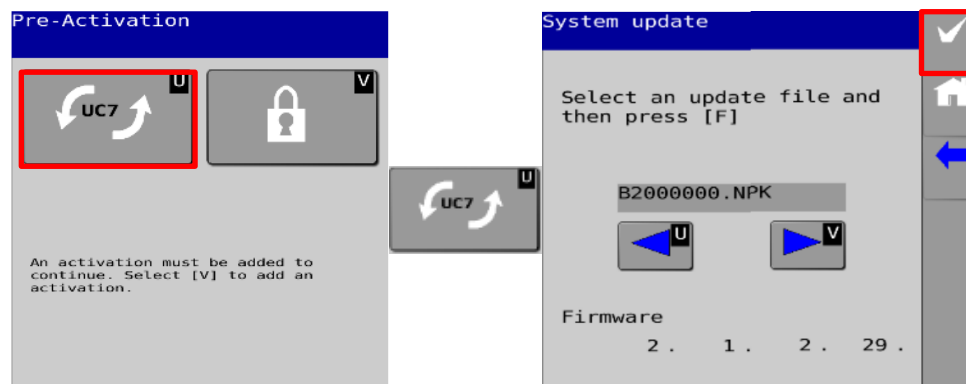

To flash new software, put the USB-drive with the right software in the HCM1 module.

Then start up boomguide and press the update button (U).

Select the software file and continue.

## 5. Software screens

### Activation

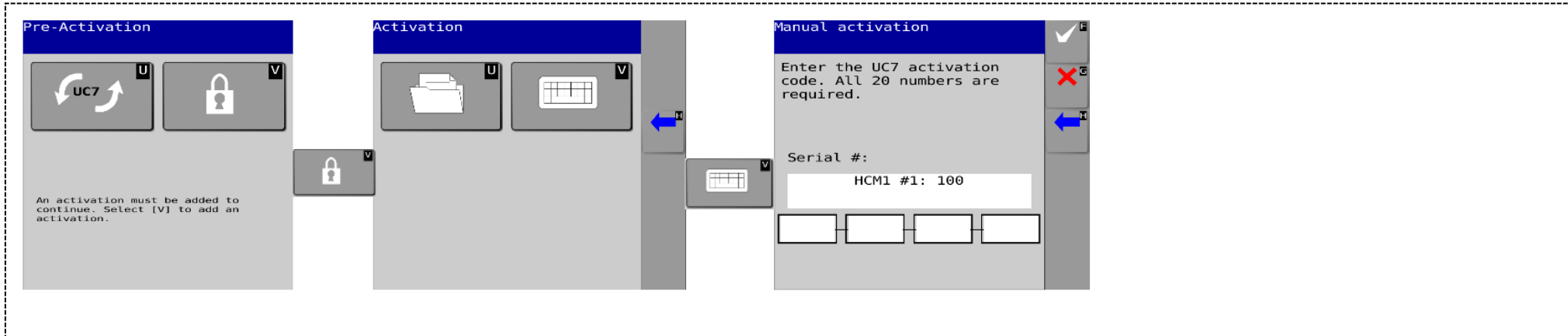

Before it's possible to use boomguide, it's necessary to activate the boomguide height control system first.

There are 2 ways to activate.

Manual:

- Power the display and press the unlock button.
- Press the "keyboard" (V) button for manual entry.
- Enter the provided activation code and press continue.

With USB:

- Power the display and press the unlock button.
- Plug the USB in the display.
- Press the "map" (U) button and select the activation code.

# 5. Software screens

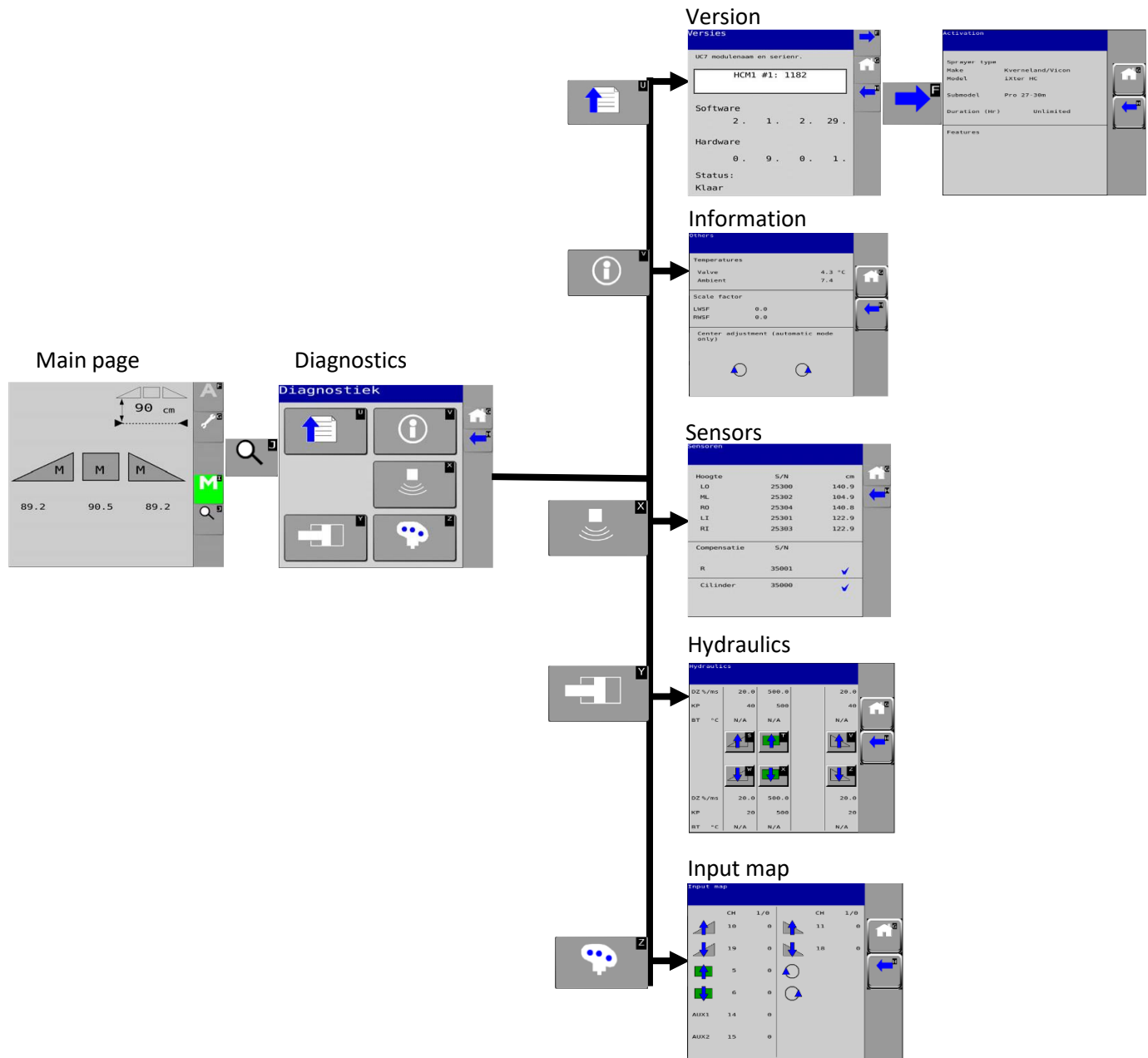

## 5. Software screens

### Diagnostic

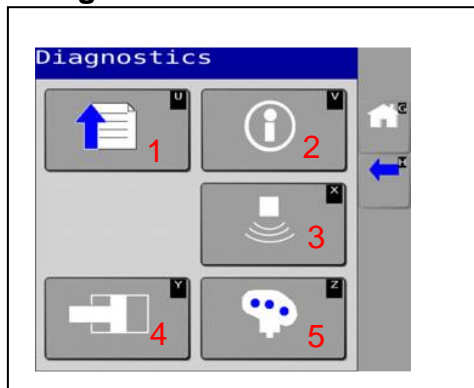

### 1- Versions

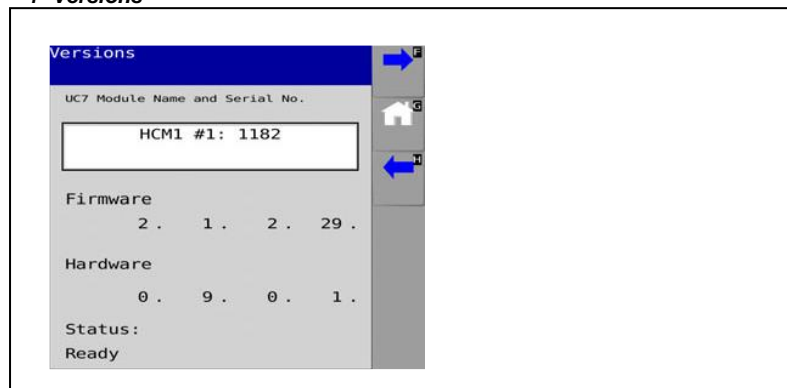

### 2- Info

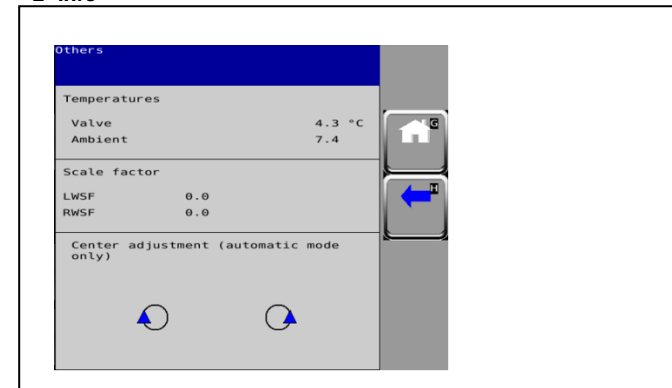

**1 – Versions.**

**2 – Info.**

**3 – Sensors.**

**4 – Hydraulic.**

**5 – Input Map.**

Software (firmware) and hardware versions of control module and height sensor.

*HCM1* – Control module (1X).

*HS* – Height sensor (3X or 5X).

Each component can be selected independently.

Temperature values.

Scale factor values are determinate at the boom push test step during the automatic setup process.

In automatic mode it's possible to adjust the center (roll) in small steps.

## 5. Software screens

### 3- Sensors

Sensors		
Height	S/N	cm
LO	30109	No data
ML	30807	77.5
RO	30809	No data
LI	30110	No data
RI	30808	No data
Compensation	S/N	
L	30110	✓
R	30808	✓

Actual height of the height sensors, together with the serial numbers.

The blue checks show that roll sensors are detected.

LO = left outer

ML = middle







RO = right outer

LI = left inner

RI = right inner

Compensation (L and R) = the 2 roll sensors within the height sensor, with 5 sensors these are always the inner height sensors.

### 4- Hydraulic

Hydraulics				
1	DZ %/ms	20.0	500.0	20.0
2	KP	40	500	40
3	BT °C	N/A	N/A	N/A
4				
				
	DZ %/ms	20.0	500.0	20.0
	KP	20	500	20
	BT °C	N/A	N/A	N/A

1- Values of the calculated deadzone for each independent cylinder









2- Values of the calculated gain for each independent cylinder

3- Values of the oil temperature during the calibration.

4- All independent cylinders can be manually operated with the buttons in this screen.

- Right wing up and down.
- Middle frame up and down.
- Left wing up and down.

### 5- Input map

Input map				
	CH	1/0	CH	1/0
	10	0		11
	19	0		18
	5	0		
	6	0		
AUX1	14	0		
AUX2	15	0		

CH are the sprayer input channels. When boom function is pressed, the status will change from 1 to 0.

# 5. Software screens

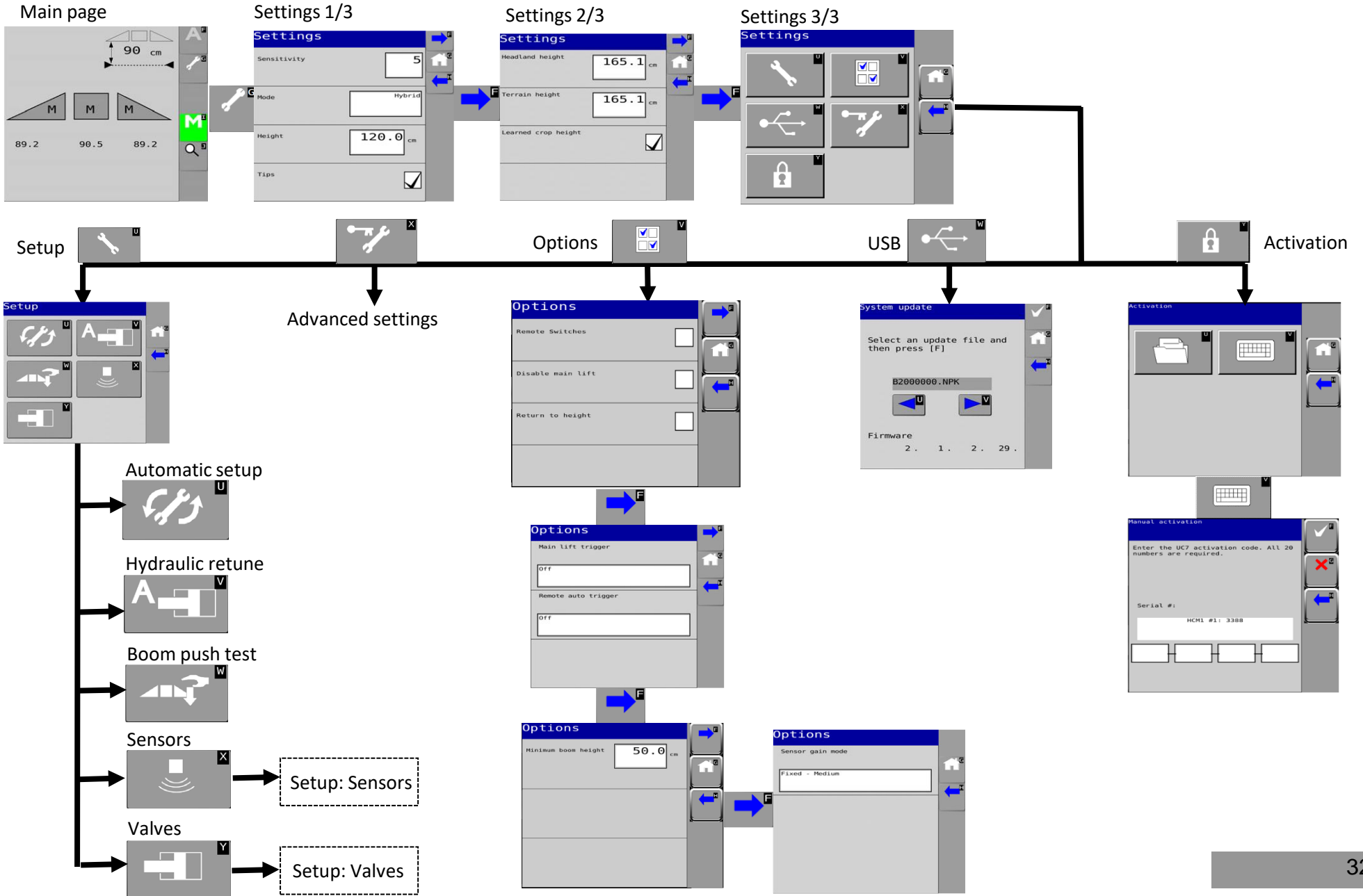

# 5. Software screens

Setup: Sensors

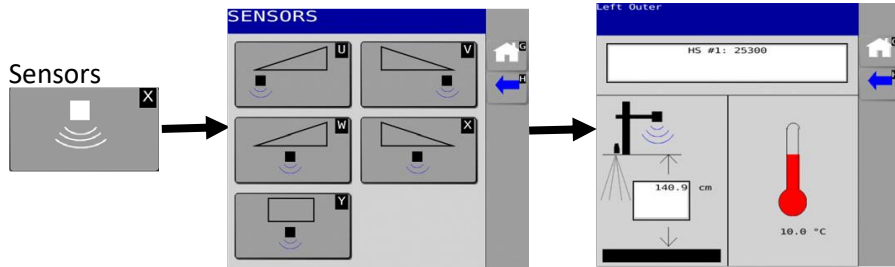

Setup: Valves

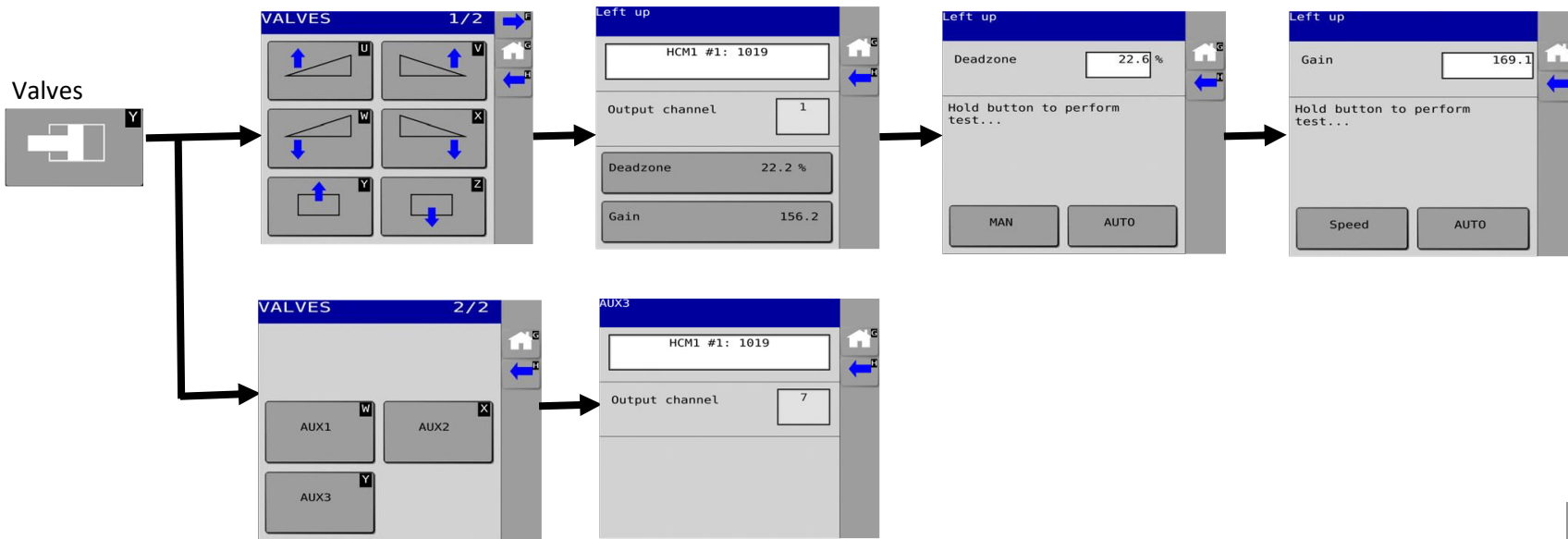

## 5. Software screens

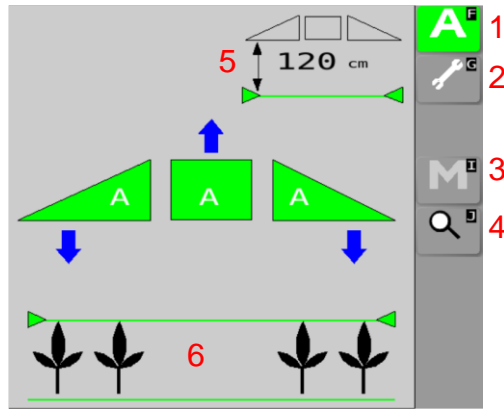

*Boomguide active (automatic mode)*

### Home screen

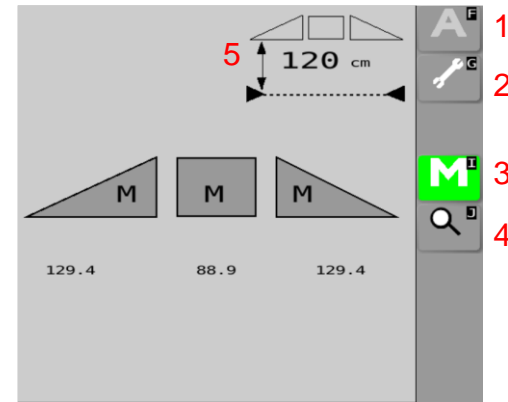

*Boomguide dis-active (manual mode)*

1 – Automatic mode (boomguide active). Green is selected (active), Grey is deactive.

2 – Spanner. Press to go to settings.

3 - Manual mode (boomguide deactive). Green is selected (active), Grey is deactive.

4 - Magnifier. Press to go to diagnostics.

5 - Target height. Target height cannot be changed in home screen.

6 - Height reading mode. Only visible when automatic mode is activated Crop mode (green on top) Soil mode (green line on the bottom) Hybride mode (green line on top and bottom).

7 – Change to next Virtual Terminal. Only visible when manual mode is active and there are more than 1 virtual terminal active on the CANbus.

# 5. Software screens

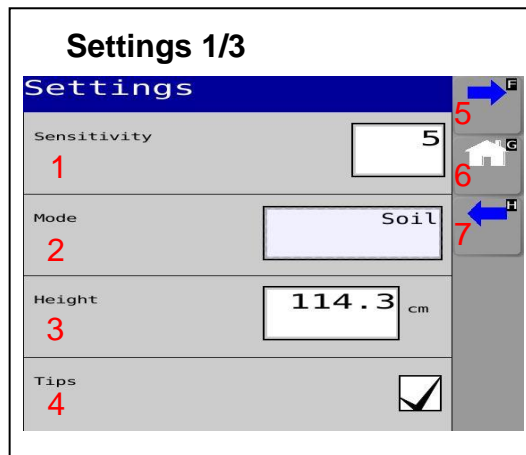

## Height reading mode

### Soil Mode

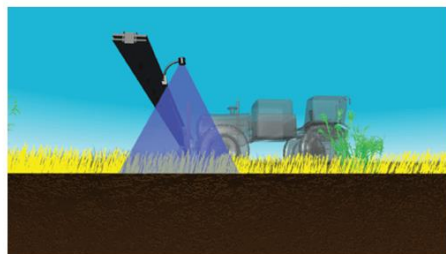

### Crop Mode

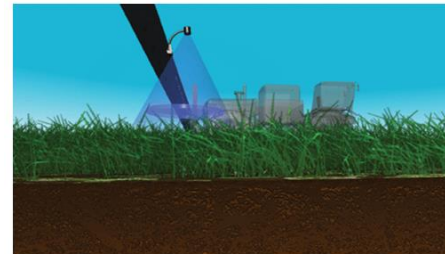

### Hybrid Mode

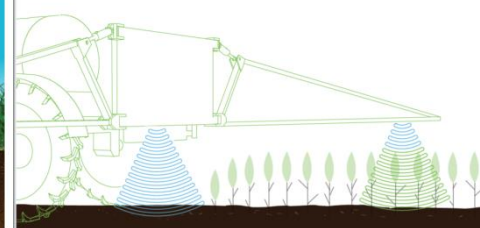

**1 – Sensitivity** (1-10). By increasing the value the total boomguide system will react faster on height differences.

### 2- Mode.

- Soil mode.
- Crop mode.
- Hybrid mode.

### 3-Target height.

**4-Tips on/off.** Switch on/off outer height sensors (only visible when 5 sensors are mounted).

**5- Next page** (settings 2/3)

**6- Home page**

**7- Previous page**

**Soil mode** System will read the height from the ground (soil) to the sensor (longest signals).

**Crop mode** System will read the height from the crop tops to the sensor (shortest signals).

**Hybrid mode** will read the height from the ground to the sensors and from the crop tops to the sensors simultaneously (both signals). With this information the software is calculating an average crop height. When the crop height suddenly decreases (tramlines / falling down crops because of weather conditions/etc.), the boom will not steer down. Instead of steering down the software starts to steer the boom height to the average crop height.

Crop mode

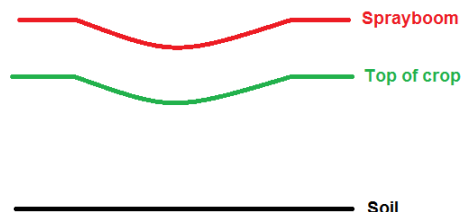

Hybrid mode

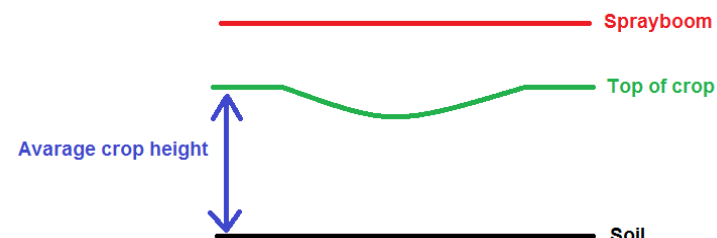

## Settings 2/3

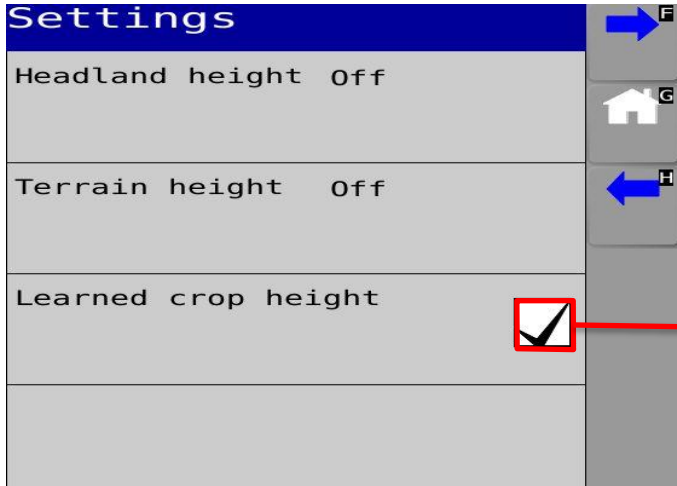

The Height sensor will automatically learn the crop height

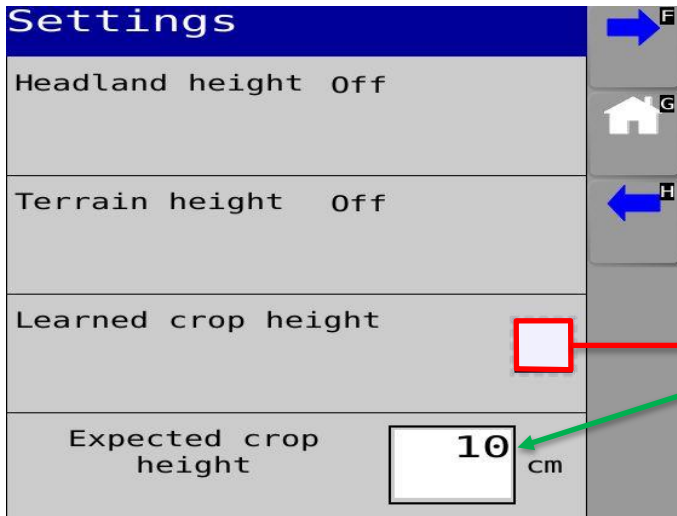
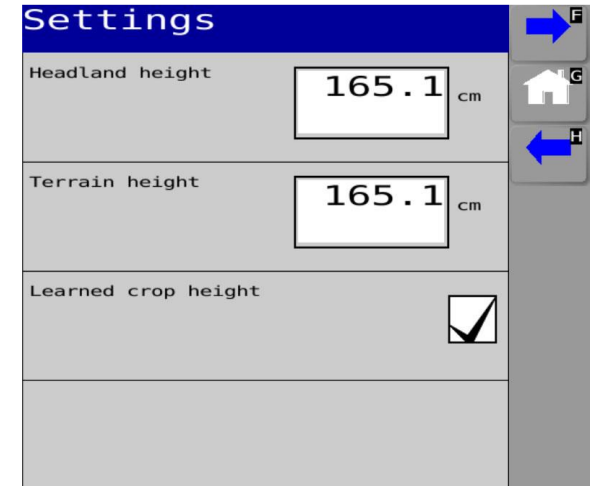

The crop height must be manually entered in case the crop is too thick and sensor not able to read the soil.

Determine the height of the booms during headland assist.

Determine the height of the booms during terrain assist.

(Only possible when headland or terrain assist is activated in the "options" menu).

# 5. Software screens

## Tips on/off

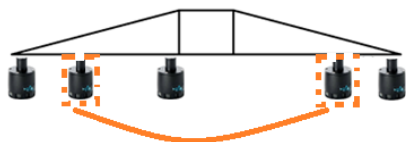
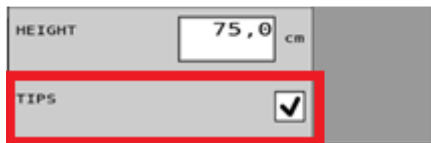

Only active if closer than 20 cm from target height

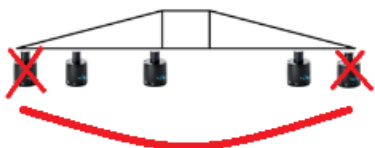
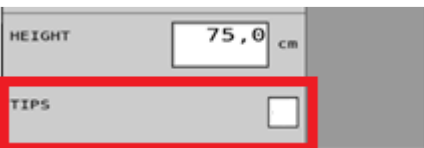

Tip sensors are not active when unchecked

## Settings 3/3

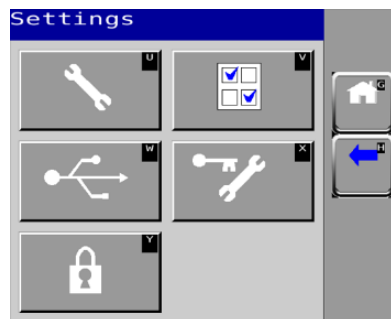

(Settings menu is only visible in manual mode)

- 1- Setup menu (u)
- 2- Options menu (v)
- 3- USB menu (w)
- 4- Advanced menu (x)
- 5- Activation (y)

## Setup menu

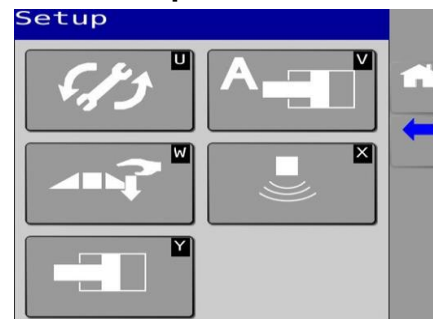

- 1- Automatic setup (u) Chapter 8
- 2- Hydraulic retune (v) Chapter 7
- 3- Manual pushtest (w) Chapter 10.1
- 4- Sensors (x) Chapter 10.2
- 5- Valves (y) Chapter 10.3

## 5. Software screens

### Sensors

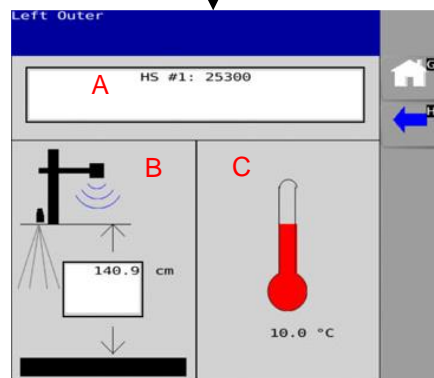
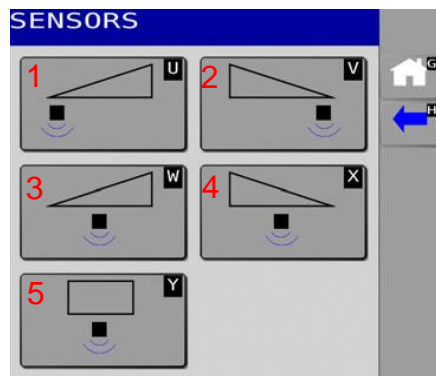

- 1 - Setting of the left height sensor.
- 2 - Setting of the right height sensor.
- 3 - Setting of "in-between" sensor on left side (optional).
- 4 - Setting of "in-between" sensor on right side (optional).
- 5 - Setting of the middle height sensor.

### Height Sensors (1-5)

*A* - Serial number of the corresponding height sensor (check page 13/14 for more information about the serial number of the height sensor).

*B* - Height to the ground of nozzle closest to the corresponding height sensor (adjustable).

*C* - Outside temperature.

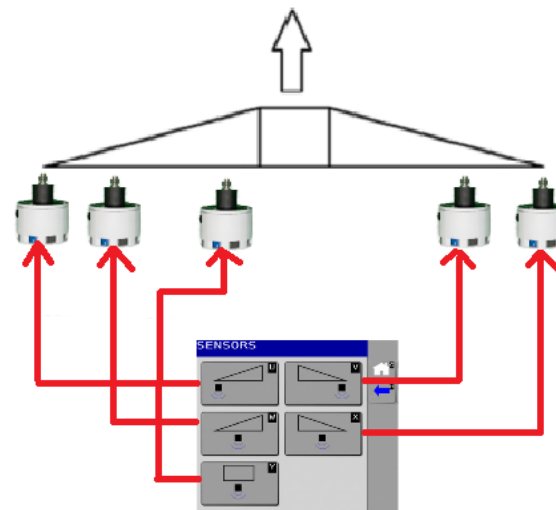

# 5. Software screens

## Valves

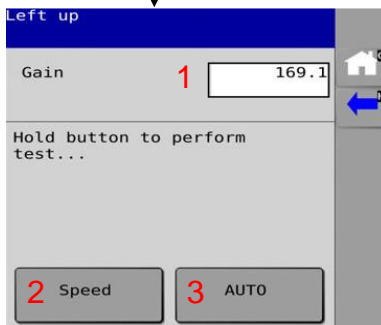
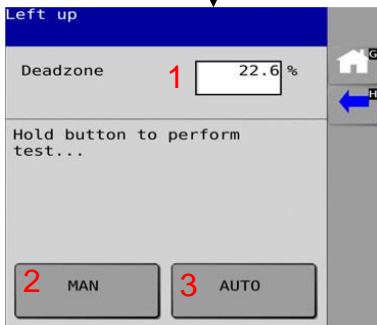
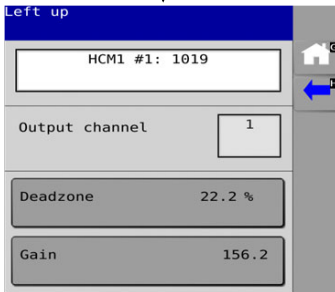
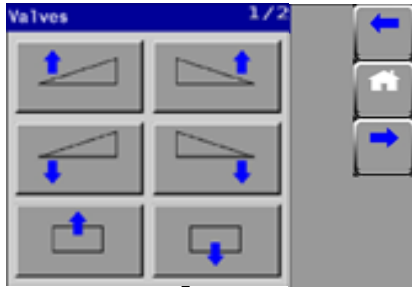

The cylinders are steered by the boomguide system in 2 steps:

- 1) Big step = Gain
- 2) Small step = Deadzone

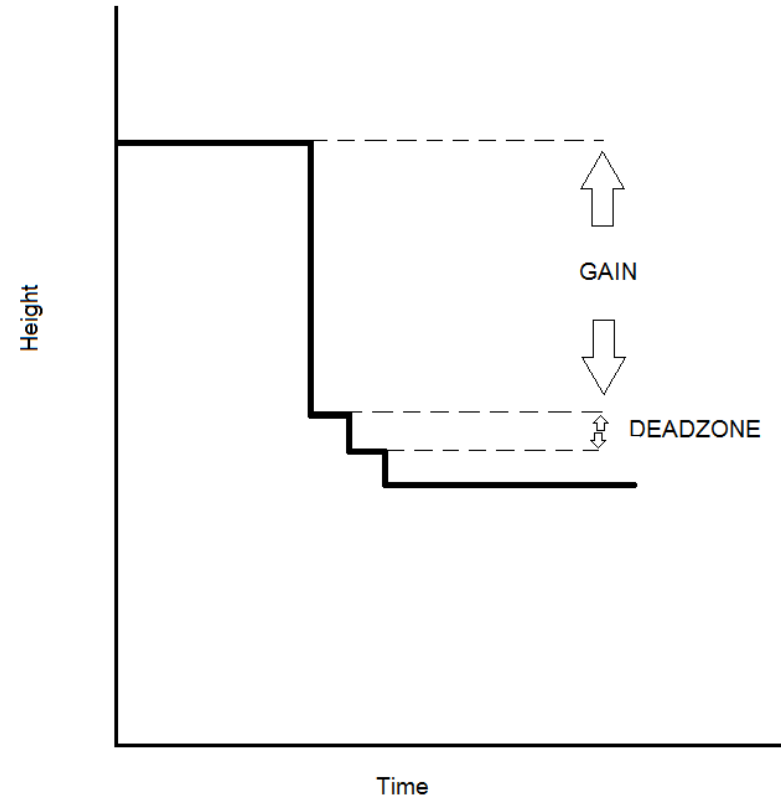

## 5. Software screens

### Gain

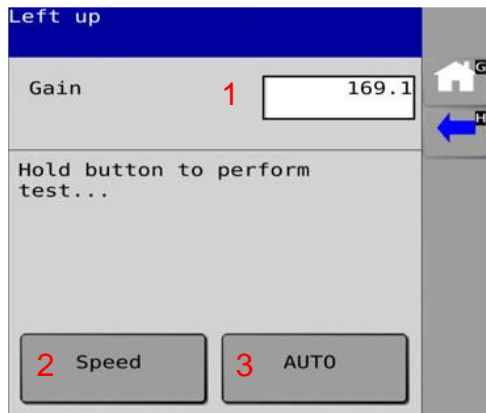

The speed of the VG cylinders down should be between 75 and 100 cm per second. This can be checked by pressing “speed” (2) button for 4 seconds.

- If the value is bigger then 100 cm, close the manual restrictor on the VG cylinder a bit, and check again.
- If the value is smaller then 75 cm, open the manual restrictor on the VG cylinder and test again.

### Deadzone

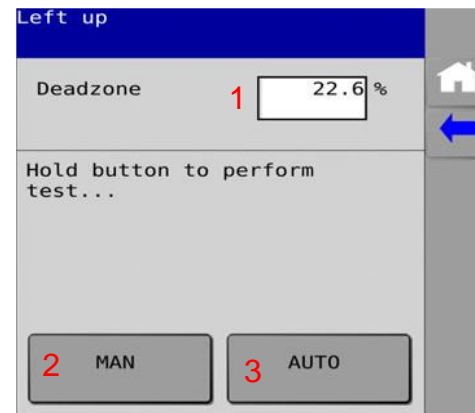

The “small steps” (deadzone) should be between 4-8 cm. This can be checked by pressing “man” (2). The button should be pressed for 4 seconds.

If the movement of the tipend of the boompert is smaller than 4 cm, the deadzone value should be increased (1).

If the movement of the tipend of the boompert is bigger than 8 cm, the deadzone value should be decreased(1).

# 5. Software screens

## Options

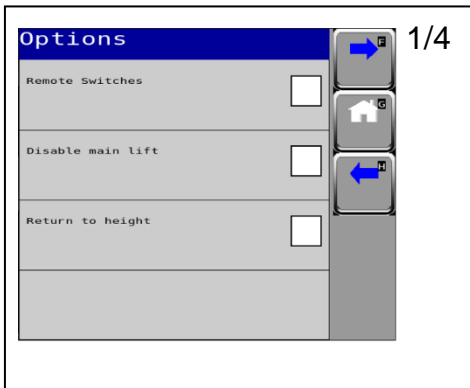

**Remote switches** When remote switches are enabled, the UC7 system can be put into automatic or manual mode using external switches.

**Disable main lift** The main lift disable option can be used to turn off the main lift output. The main lift sensor will continue to output a height reading.

**Return to height.** Always deselected at Kverneland/ Vicon sprayers.

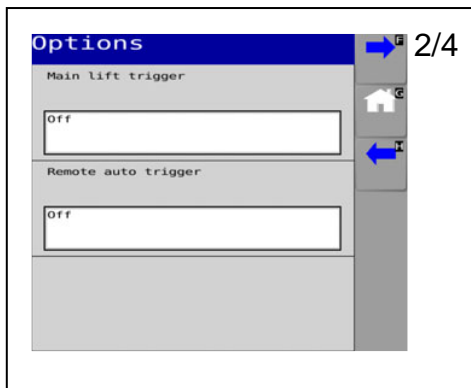

**Main lift trigger** If the main lift trigger is enabled, the feature selected will be engaged when the main up switch is pressed and disengaged when the main down switch is pressed while in automatic mode. (This is the main lift button).

**Remote auto trigger** Enabling the remote auto trigger will allow a separate switch to trigger another feature. (This is the sprayer on-off button).

## Main Lift Trigger Options

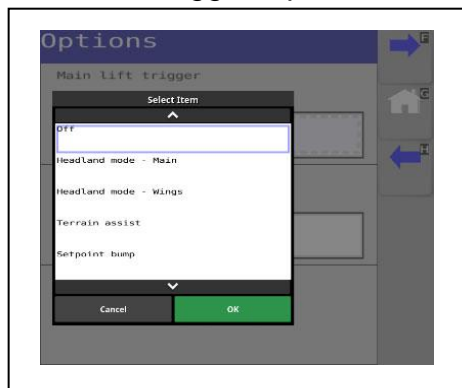

**Setpoint bump** If checked the target height can be changed with the main up/down button on the switchbox. A small tap with the button results in a 2,5 cm higher/lower target height.

**Headland mode – main** The middle frame is lifted with the ergodrive function.

**Headland mode – wings** The left and right side of the boom are lifted with the ergodrive function.

## Remote auto trigger Options

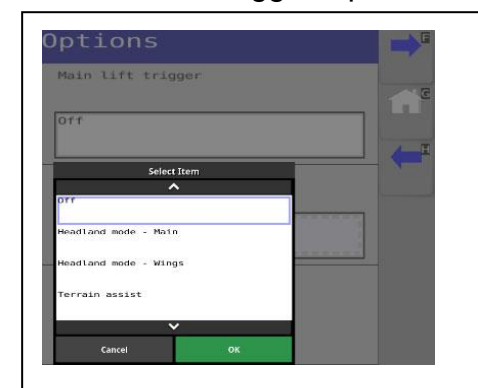

**Headland mode – main** The middle frame is lifted with the ergodrive function.

**Headland mode – wings** The left and right side of the boom are lifted with the ergodrive function.

## 5. Software screens

### Options

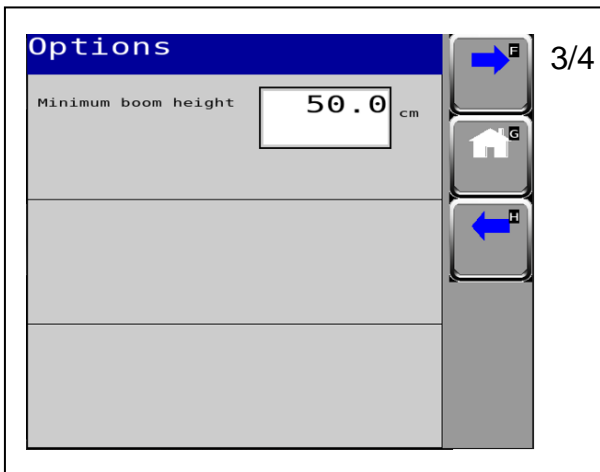

**Minimum boom height** Minimum target height which the customer can enter in operation screen.

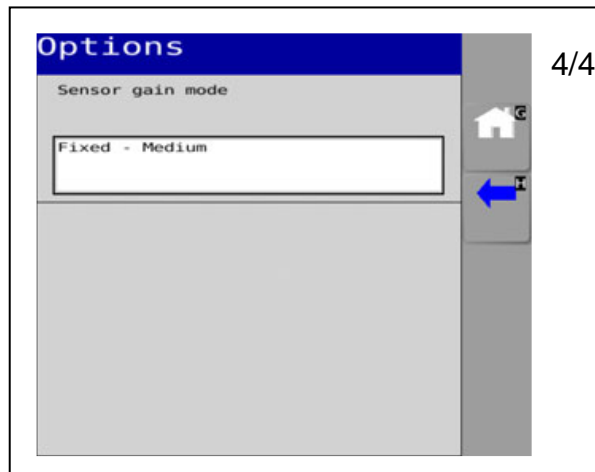

#### **Sensor gain mode**

**Conventional** For situations where non-standard sensor mounting or other factors prevent the fixed modes from functioning.

**Fixed – Medium** Default mode.

**Fixed – High** Use if the sensors have difficulty tracking the crop height in Hybrid Mode.

# 5. Software screens

## Advanced

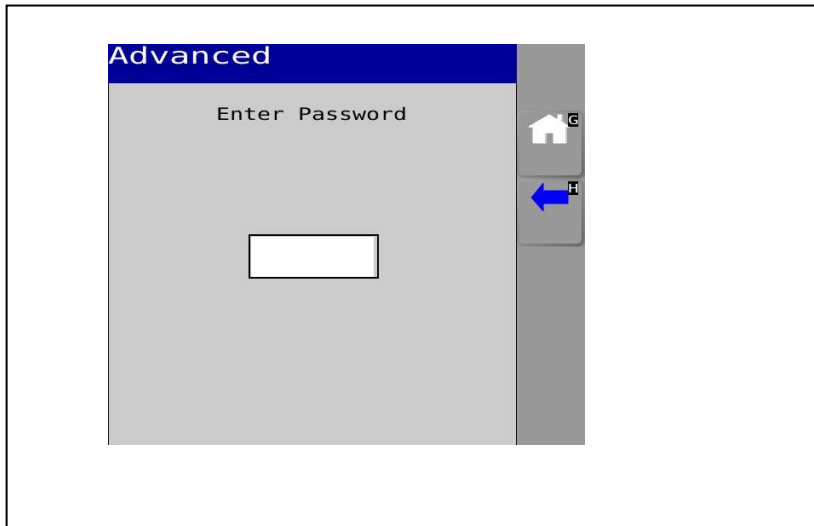
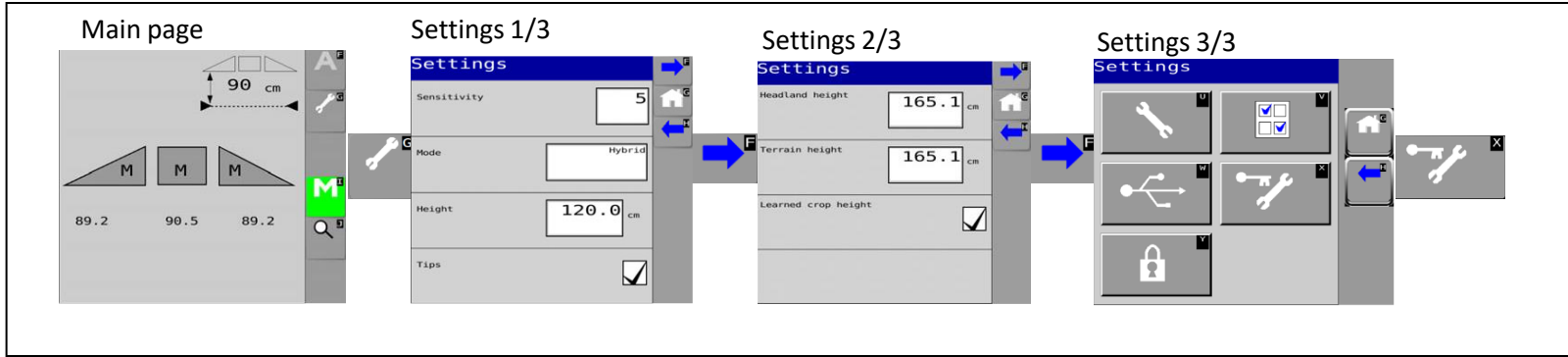

The advanced menu can be entered by filling in the level 2 password (10).

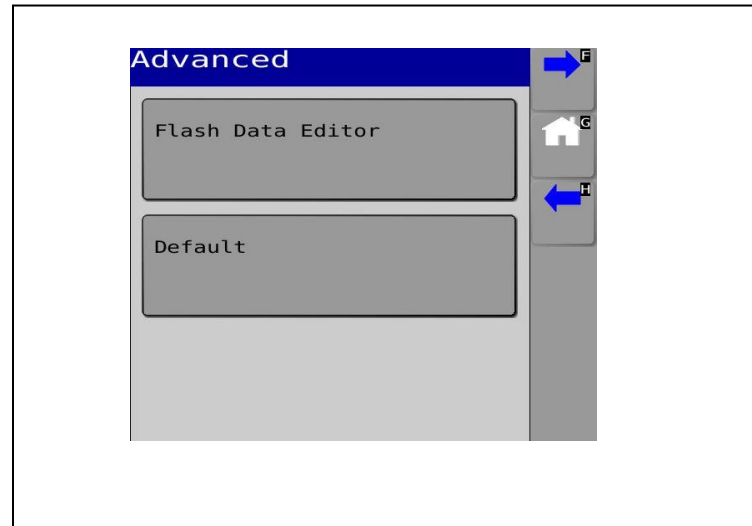

By activating the default function, all data is removed from the control module (an automatic setup has to be done afterwards).

## 5. Software screens

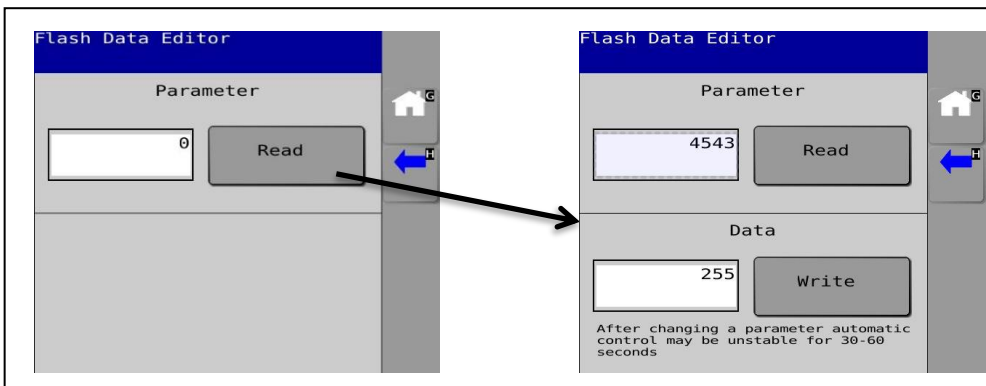

In the “flash data editor” menu, the advanced parameters can be changed.

Only change these parameters on advice of the factory.

Enter the address of the parameter and press “read”.

Change the parameter on the bottom side and press “write”.

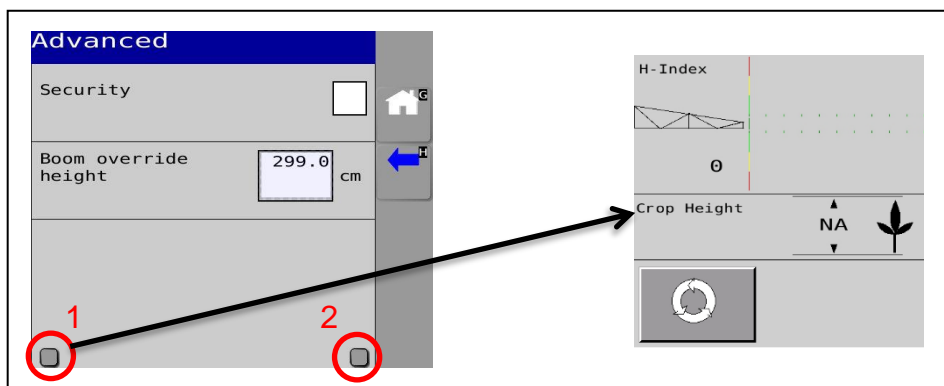

**Security**- Always on (factory setting).

**Boom override height** – Maximum height of boom when Norac is steering actively. Above this height, the system will give an alarm when the operator want to switch to automatic mode.

**Performance indication** - Performance measurement can be switched on. By pressing small square button (1), the performance measurement screen appears in 1<sup>st</sup> setting screen. Performance screen disappears again after a reboot of terminal.

**VT storage** – Previous saved screens can be deleted by pressing the right small square button (2). The system will react slower in the beginning, because all the screens have to be loaded again. This button has to be pressed after flashing UC7, to get rid of the old screens.

# 5. Software screens

## iXspray

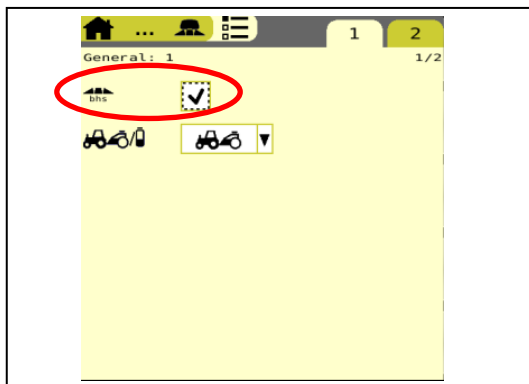
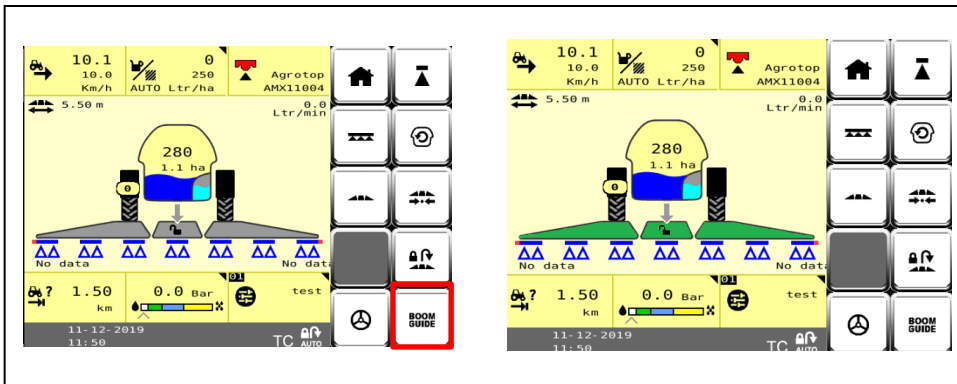

In “spraying” screen of the iXspray software, boomguide can be switched into automatic/manual mode.

If the spraybooms of are green, boomguide is in automatic mode.

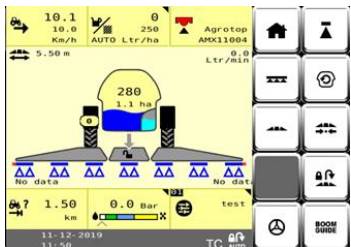

Boomguide in manual mode.

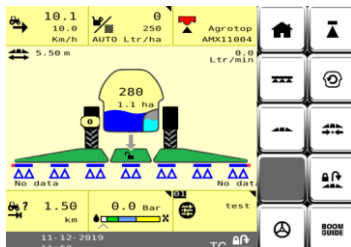

Boomguide in automatic mode.

In “implement settings-other”, there can be chosen if the actual heights of the sensors are displayed when boomguide is active.

BHS selected: actual heights of sensors are displayed in main screen when boomguide is in automatic mode.

BHS not selected: Target height is displayed in main screen when boomguide is in automatic mode.

(When boomguide is in manual mode the actual heights of the sensors are always displayed).

# 6. Ergodrive

## Ergodrive- boomguide not active on the headland

When the boomguide doesn't have to steer actively (boom goes up to 2° target height and then freeze) on the headland when ergodrive is activated, the following settings has to be done:

- Select "UC7" at the UC7 headland parameter in the ergodrive screen of the operation screen.
- Select "headland assist" in the option menu of Norac.
- Select in main lift trigger menu "headland mode main or wings (1)".
- Or Select in remote auto trigger menu "headland mode or wings".
- Power boot the terminal.

Target height during spraying and during spraying off, should be set in Norac screen now (2).

When the headland mode is on the remote auto trigger, it's possible to put the set point bump on the main lift trigger.

It's also possible to put the terrain assist on the main lift trigger. **(set point bump and headland assist can not be active while terrain assist is enabled).**

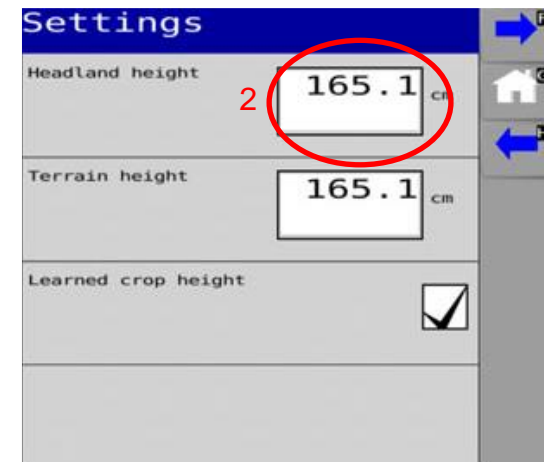
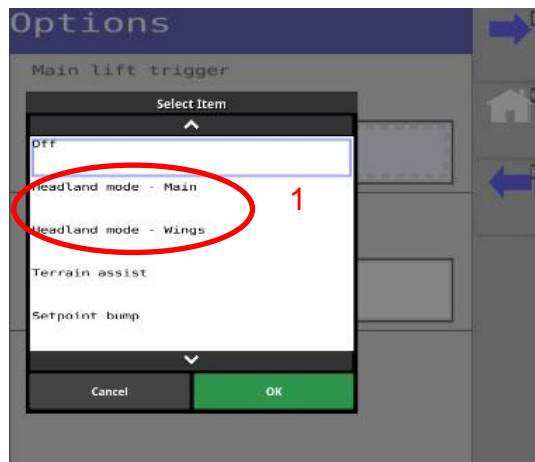
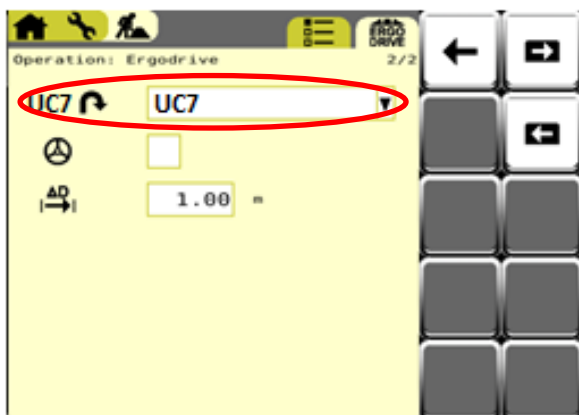
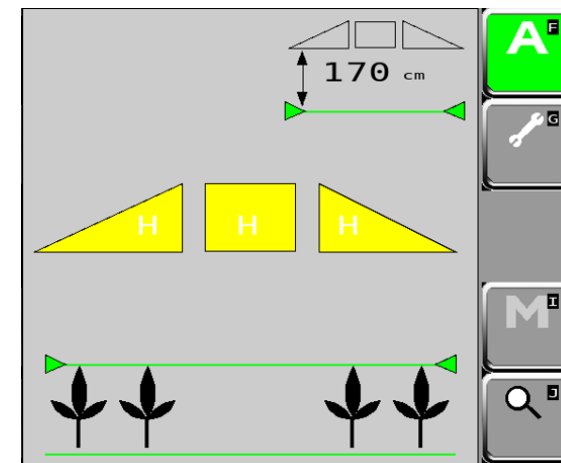

# 6. Ergodrive

## Ergodrive- boomguide active on the headland

When the boomguide also has steer active on the headland when ergo drive is activated, the following settings has to be done:

- Select "machine" (1) at the UC7 headland parameter in the ergodrive screen of the operation screen.
- The remote auto trigger in Norac automatically goes to headland mode and the options here are "main" or "wings" (2).
- Its possible to put the setpoint bump on the main lift trigger in Norac, but not terrain assist because they cant be used at the same time.
- Power boot the terminal.

Target height during spraying and during spraying off should be set in the preset screen now.

The Ergodrive function should be activated in the main screen. Ergodrive is reacting on the main switch valve of the switchbox.

**Note.** When boomguide steers active on the headland, there is a risk that the boom reacts on external height changes on the headland (water ways, bushes, etc.)

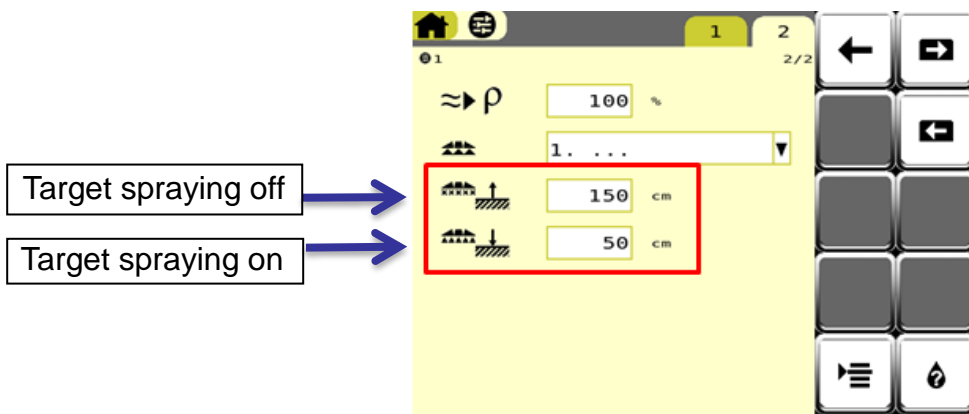
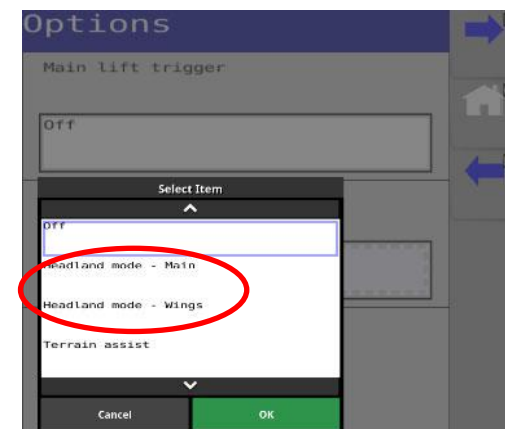
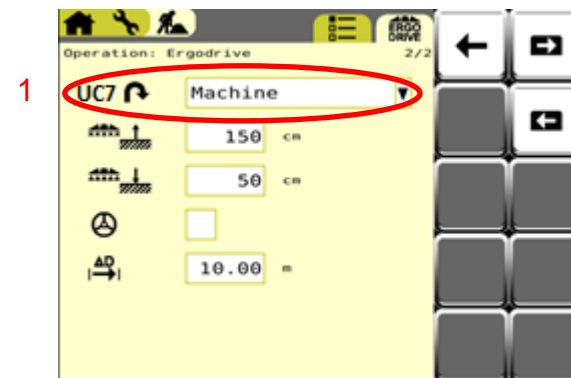

## UC7 Retune



A hydraulic retune should be done:

- At first delivery.
- Change of tractor.

### Step 1

Before starting the hydraulic retune make sure:

- Shock absorbers and springs are set right.
- The sprayboom is exactly horizontal and about 90 cm above the surface.
- The oil is on working temperature.
- The motor RPM of the tractor is same as while spraying.
- The sprayer pump is running with at least 100 litre in the main tank.
- The sensors are above the right surface (asphalt/gravel/big pieces or cardboard underneath the sensors).

### Step 2

- Put the boomguide system in manual mode.
- Go to the hydraulic retune menu.

# 7. Hydraulic retune

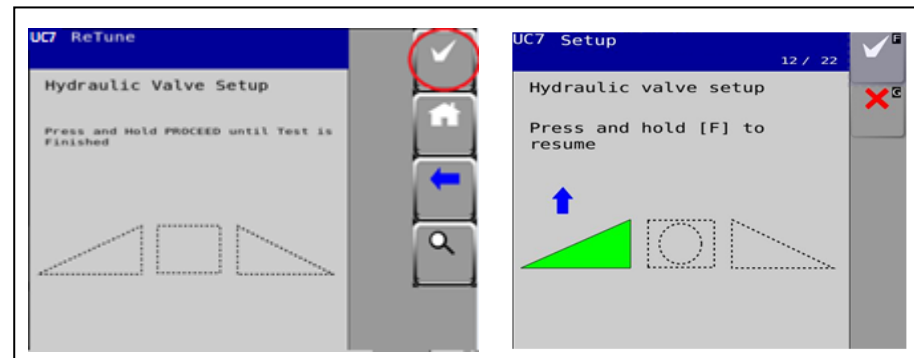
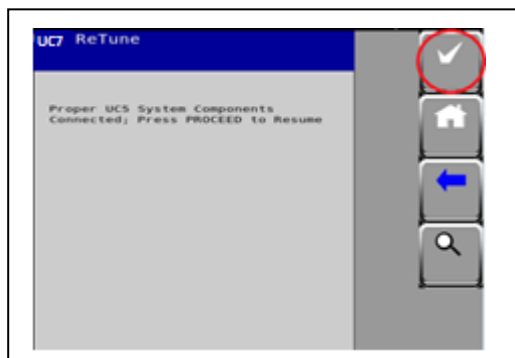
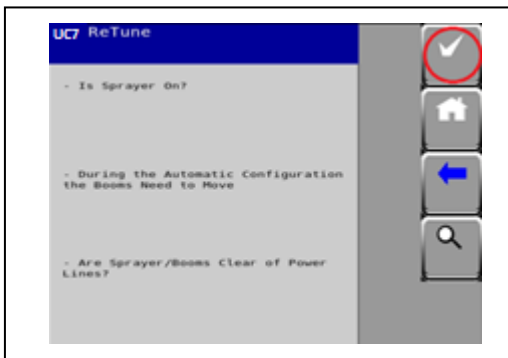

## Step 3

Read the instructions carefully and press “proceed” (4 pages).

## Step 4

The system is checking if all components of the system are connected.

Press “proceed” if the system has located all UC7 components.

## Step 5

Press and hold the “proceed” button.

The boom is moving automatically.

The system will define the KP (gain) and DZ (deadzone) for left up/down, right up/down and main up/down.

This process can take several minutes.

Select the “Check Mark” button to complete the retune.

**Extra setup settings are not necessary after the hydraulic retune is finished.**

# 8. Automatic setup

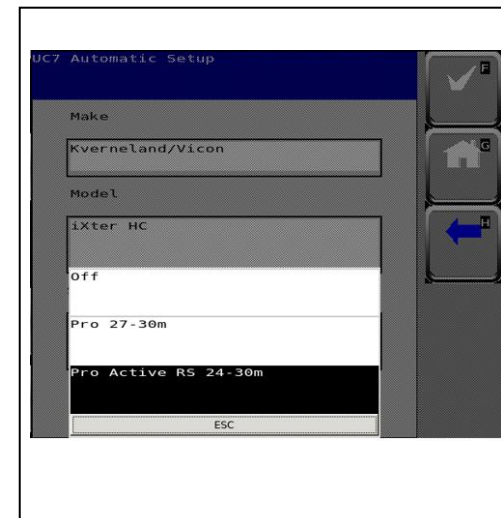
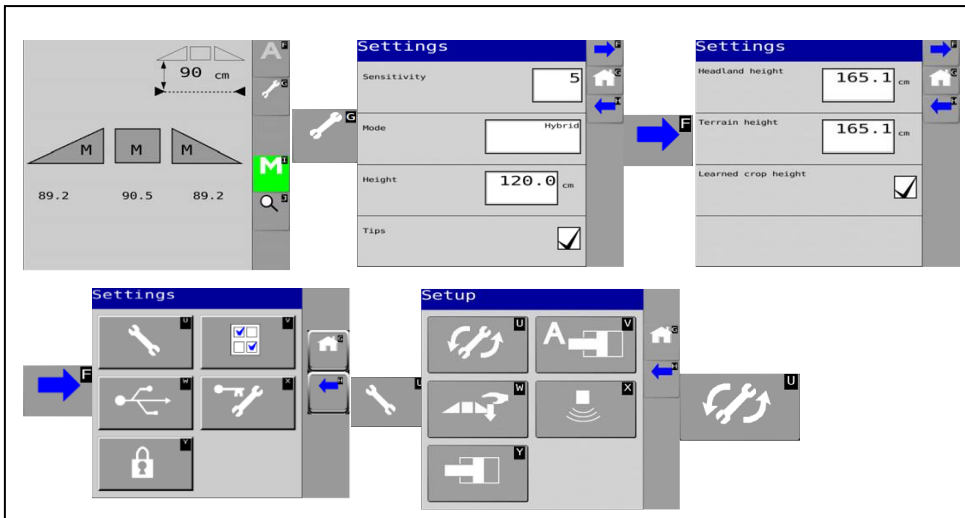

## Step 1

An automatic set-up is just for factory and **only** necessary after flashing new software or after a total default.

Before starting the automatic setup make sure:

- Make sure the booms are flat.
- Shock absorbers and springs are set right.
- The oil is on working temperature.
- The motor RPM of the tractor is same as while spraying.
- The sensors are above the right surface (asphalt/gravel/big pieces of cardboard).

## Step 2

- Put the boomguide system in manual mode.
  - Go to the "automatic setup" menu.
- (Password 20)

## Step 3

Select "Make" (brand) and "Model" (type).

Make = Kverneland/Vicon or Kubota.

Model = iXterB of Xtrack T3, T4 or T6

The profiles available are linked to the activation code.

Press "confirm" to continue.

## 8. Automatic setup

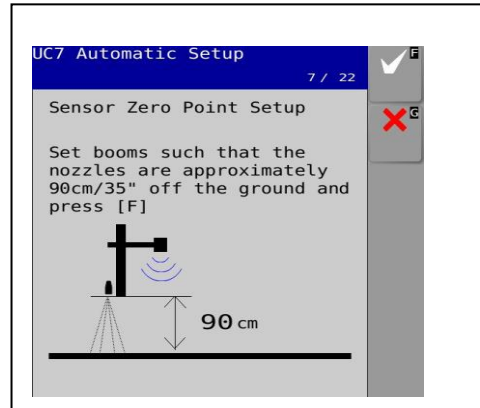
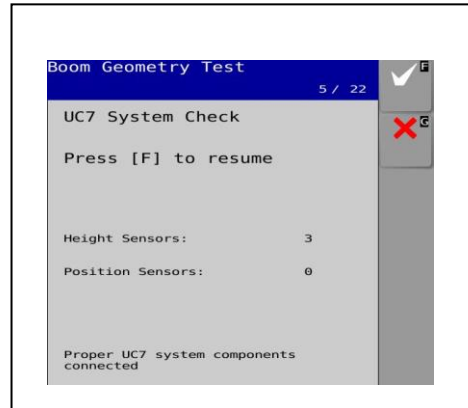
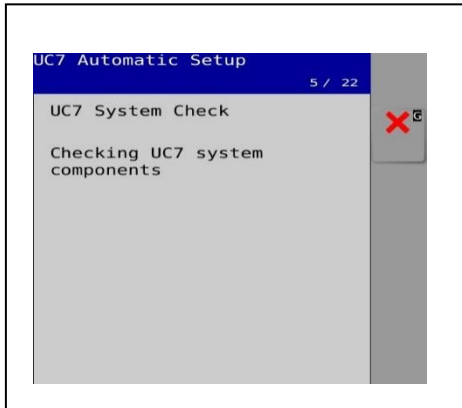

### Step 4

System will load the settings and check all modules connected on the bus regarding the profile chosen.

### Step 5

The system is checking if all components of the system are connected.

Press "confirm" when all UC7 components are connected.

### Step 6

Set the spraybooms manually at 90 cm above the ground.

Press "confirm" to continue.

## 8. Automatic setup

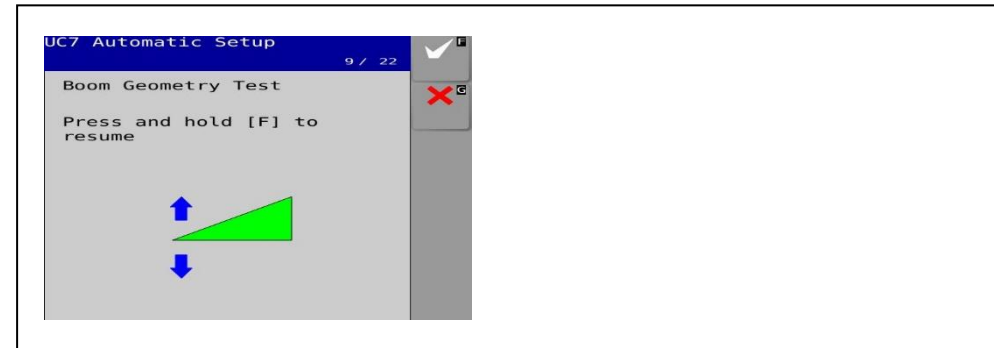
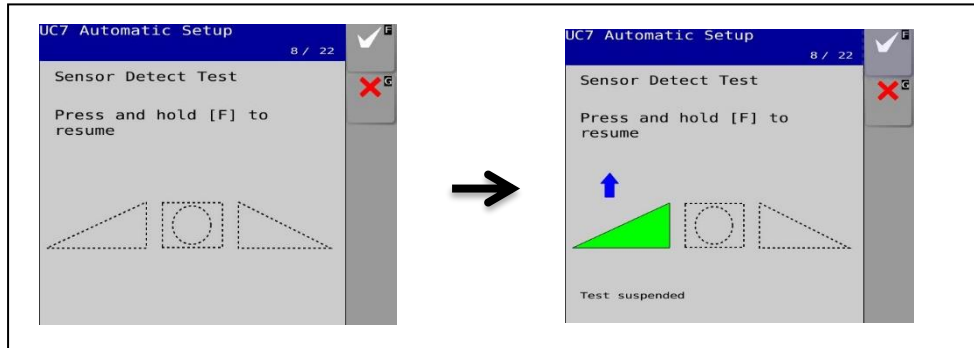

### Step 7

Press and hold the “proceed” button.

The boom is moving automatically.

The system checks if height changes are measured at all 3 or 5 sensors.

This process can take several minutes.

### Step 8

Press and hold the “proceed” button.

The boom is moving automatically.

The system will define the KP (gain) and DZ (deadzone) for left up/down, right up/down, main up/down.

This process can take several minutes.

## 8. Automatic setup

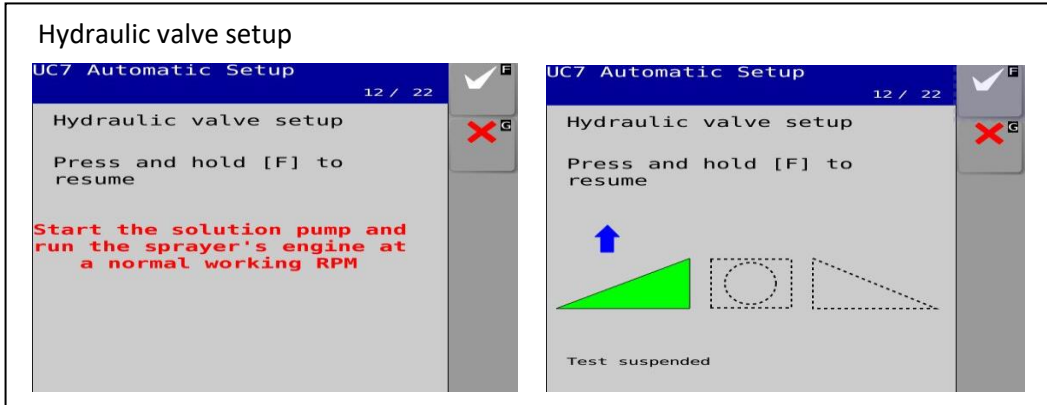

### Step 9

Start the solution pump and run the sprayers engine at a normal working RPM.

Press and hold "F", the system will set all hydraulic valves driven by the system. The boom will move up and down itself for couple minutes.

# 8. Automatic setup

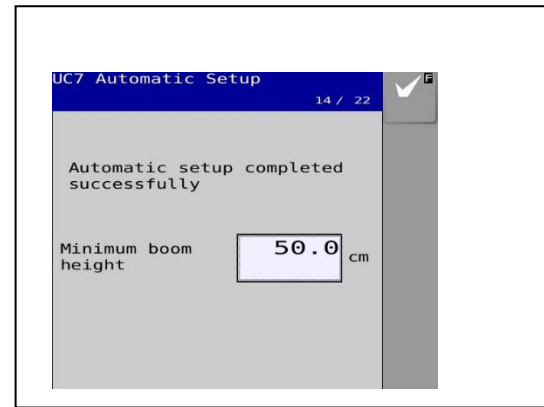
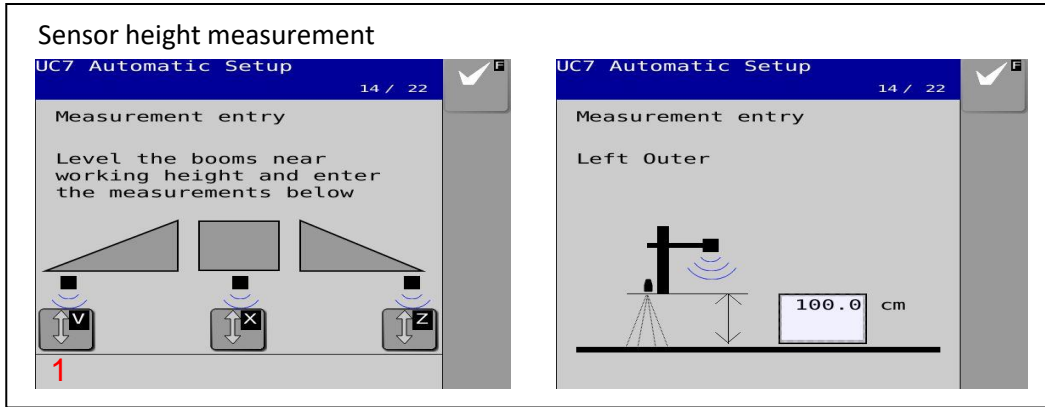

## Step 10

Measure and put the correct height for the left, right and middle sensor (1).

Exit the cabin and measure the height from the soil to the nearest nozzle at the sensor, enter these values and press "F".

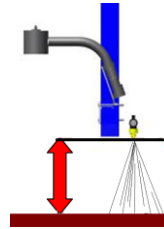

## Step 11

Enter 50 cm as minimum boomheight.

This means that the boom will not be lower than 50 cm when Norac is active.

Press "F" to complete the automatic setup.

Powerboot the system after the automatic setup (terminal off-on).

**Extra setup settings are not necessary after the automatic setup is finished.**

## 9.1 How to:

- Automatic setup (only factory)
- Retune
- Sensor offset
- Checking Deadzones
- Checking Gains

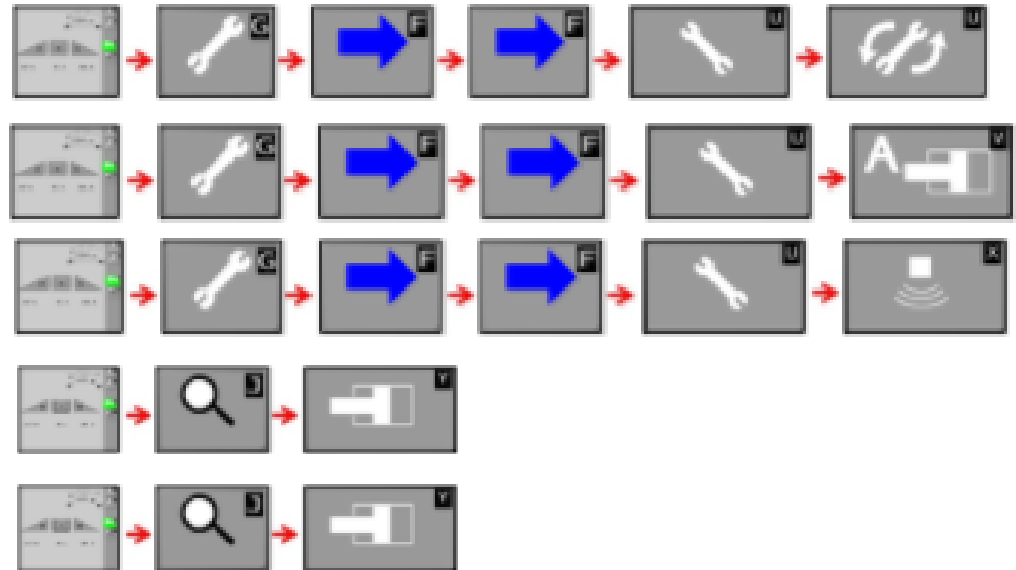

# 10.1. Setup: boom push test

## Geometry test/push test

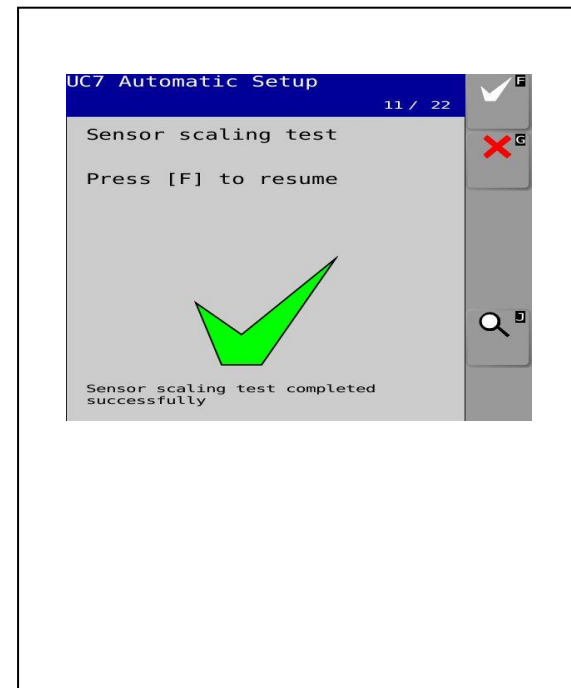
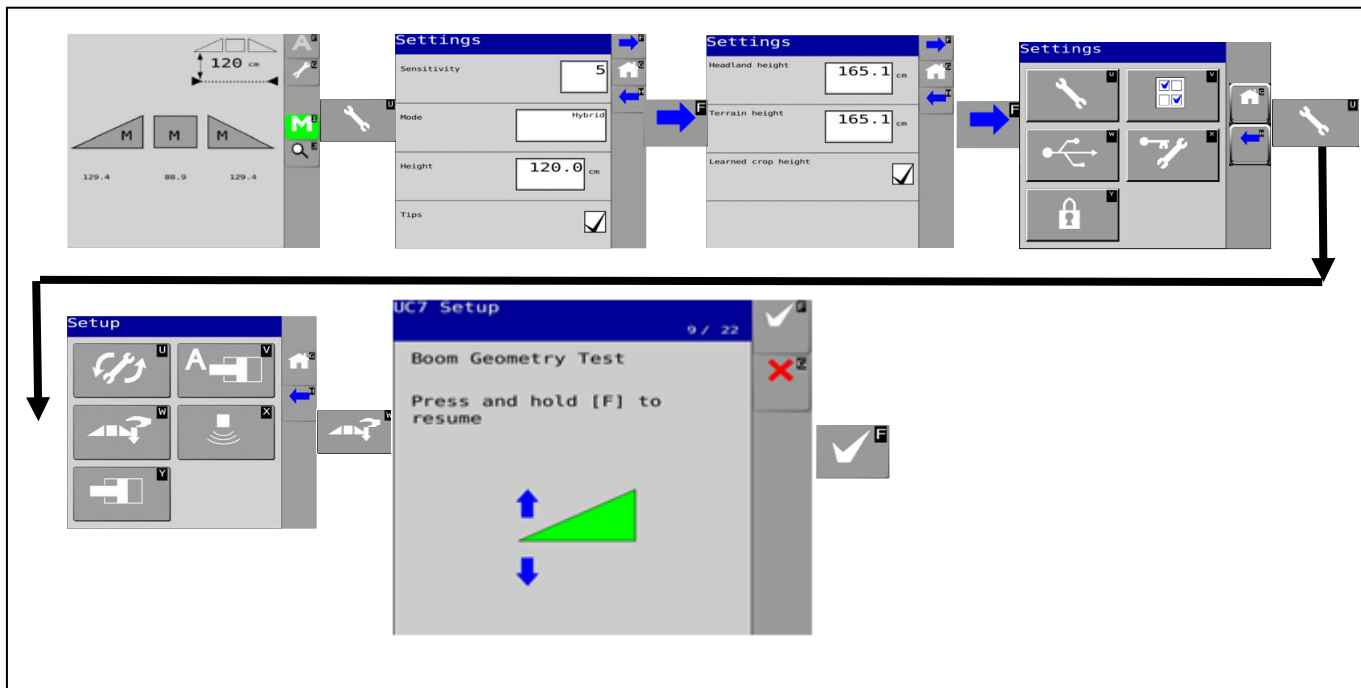

### Step 1

Press and hold "F" until the system tells you to release the button.

### Step 2

Press "F" to finish the geometry/push test.

## 10.2. Setup: sensors

### Sensors

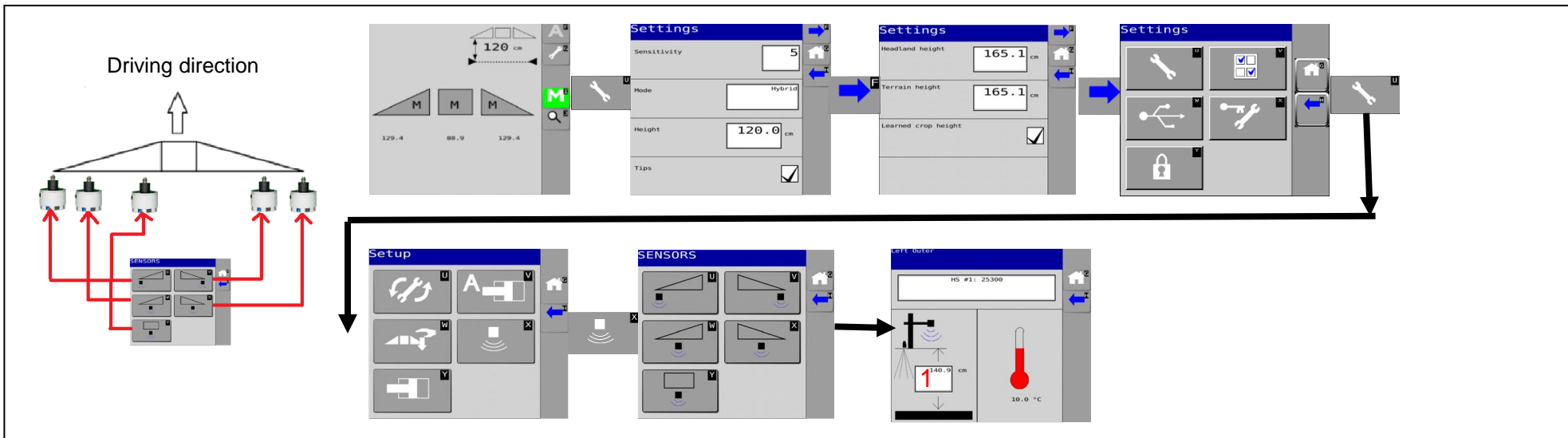

Measure and fill in the correct height for the left, right and middle sensors (1).

**(Measure the height from the soil to the nearest nozzle at the sensor).**

## 10.3. Setup: valves

### Valves

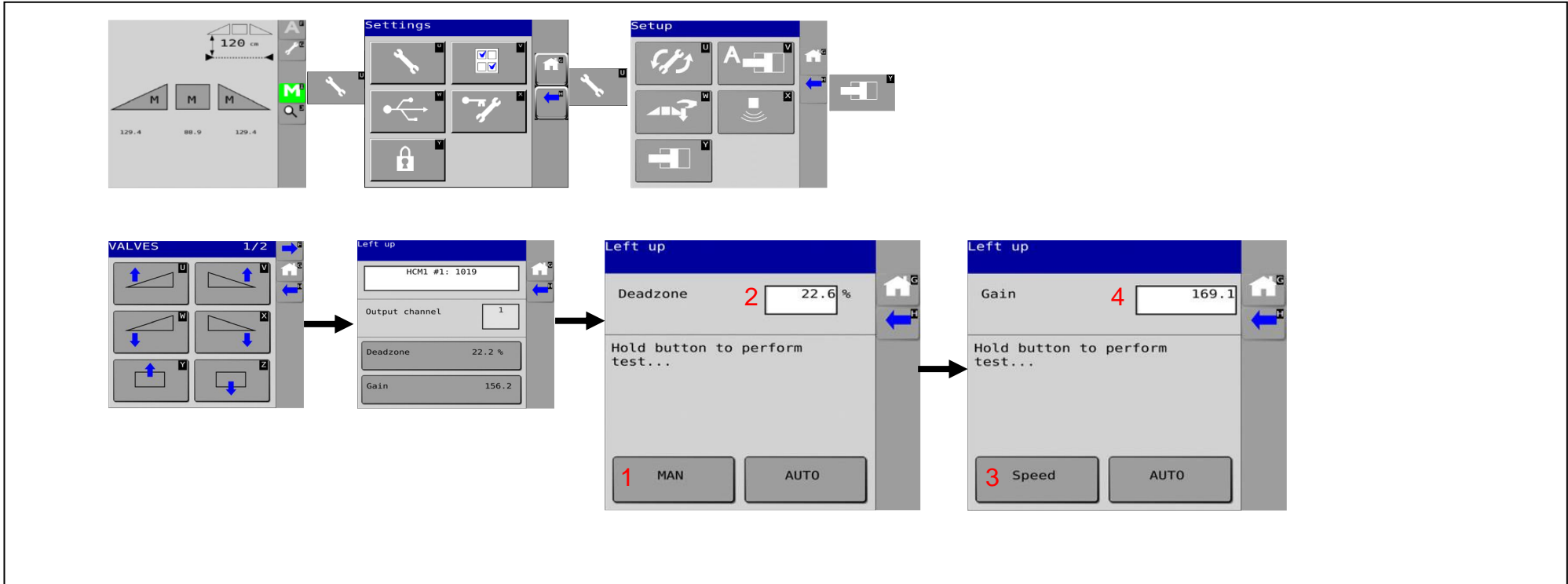

Check the deadzones by pressing “man”(1) for 3 seconds.

The movement of the tipend should be between 4 and 8 cm (movement can be checked by value in the screen).

If the movement of the tipend of the boompert is smaller than 4 cm, the deadzone value (2) should be increased.

If the movement of the tipend of the boompert is bigger than 8 cm, the deadzone value (2) should be decreased.

Check the gains by pressing “speed” (3) for 3 seconds. The speed of the VG cylinders down should be between 75 and 100 cm per second.

- If the value is bigger then 100 cm, close the manual restrictor on the VG cylinder a bit, and check again.
- If the value is smaller then 75 cm, open the manual restrictor on the VG cylinder and test again.

# 11. Flashing

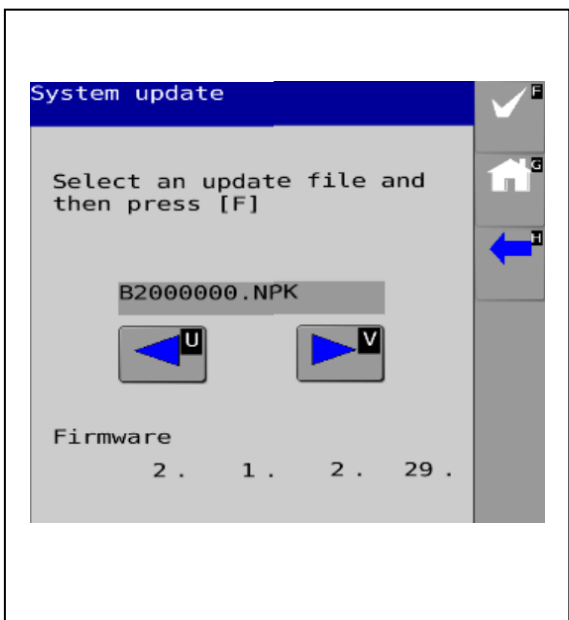
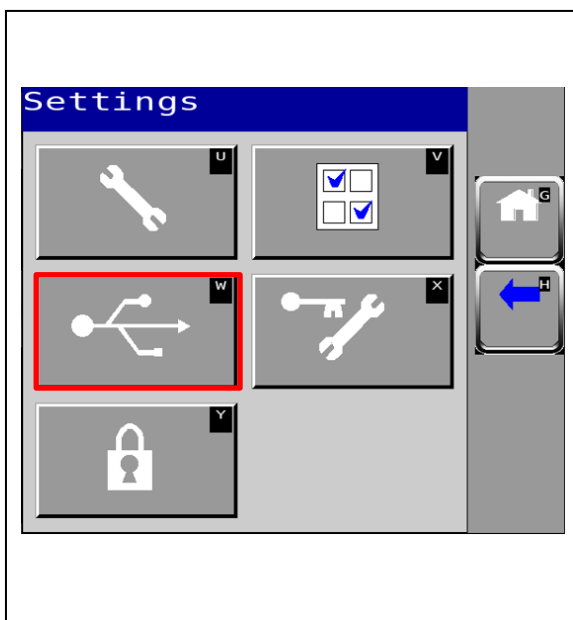
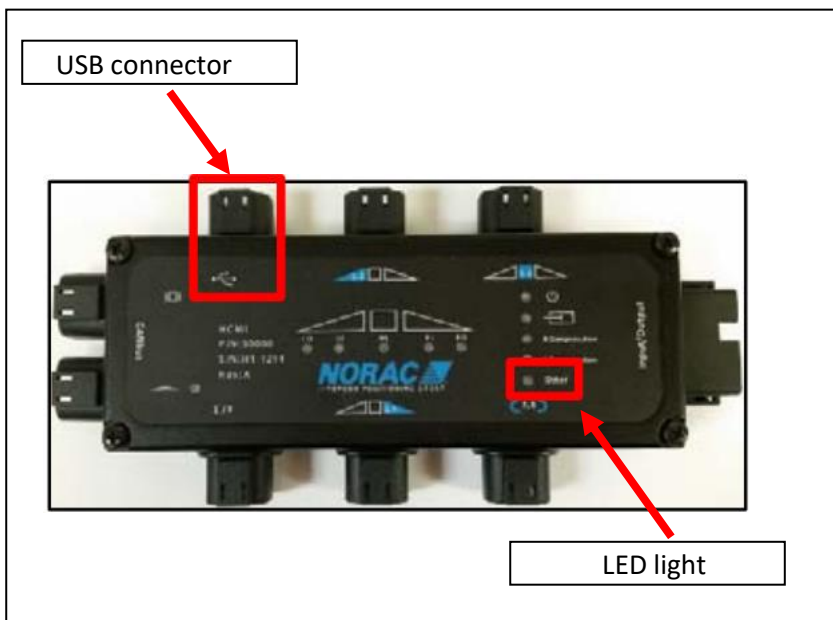

Insert a USB drive loaded with the update file into the USB connector on the HCM1. The LED light will turn green.

**(It has to be a small USB drive, otherwise it won't fit into the connector).**

Navigate to the settings menu and select the "USB" button.

Select the update file and press the "F" button.

Reboot the machine after the machine is updated.

An automatic setup needs to be performed each time a firmware update is completed.

# 12. Trouble shooting flowchart

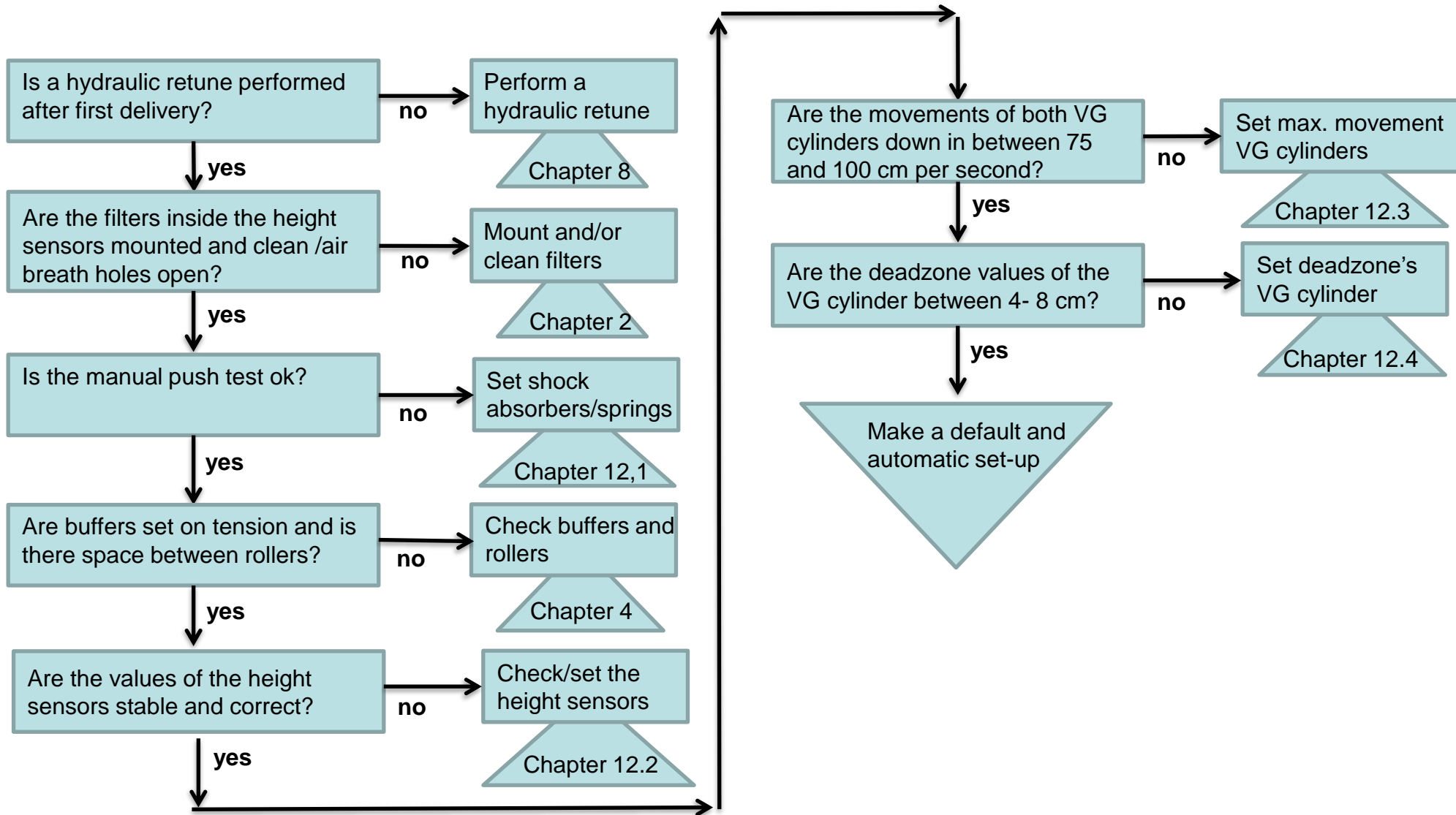

# 12.1 Manual push test

To make sure that the springs and shock absorbers are set correctly in the middle frame, a manual push test can be done.

- Set boomguide to manual mode.
- Set the boom manual horizontal with the slope correction cylinder.
- Push the boom approximately 60 cm down on 1 side (manual).
- Keep your other hand on the “original” position of the boom (green line).

### Situation 1

If the boom is overshooting = boom overshoots your hand and comes down to original position afterwards. Tight the shock absorbers and/or loosen the springs.

### Situation 2

If the boom is too slow = boom is not coming back to original position, but stays a few cm. below the original position. Loosen the shock absorbers and/or tighten the springs.

### Situation 3

The boom comes directly back to the original position. This is how it is supposed to be. Setting of shock absorbers and springs are ok.

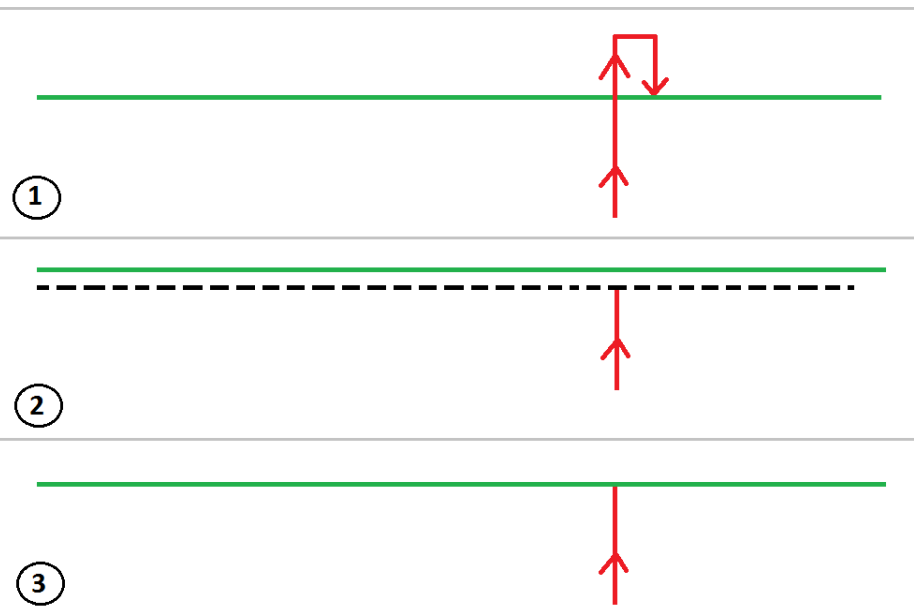
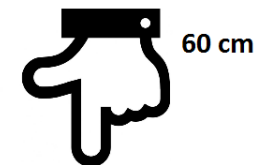
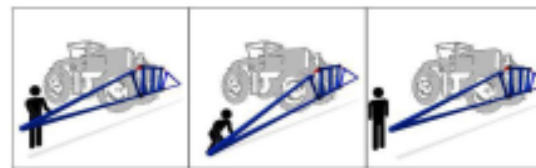

## 12.2 Height sensors

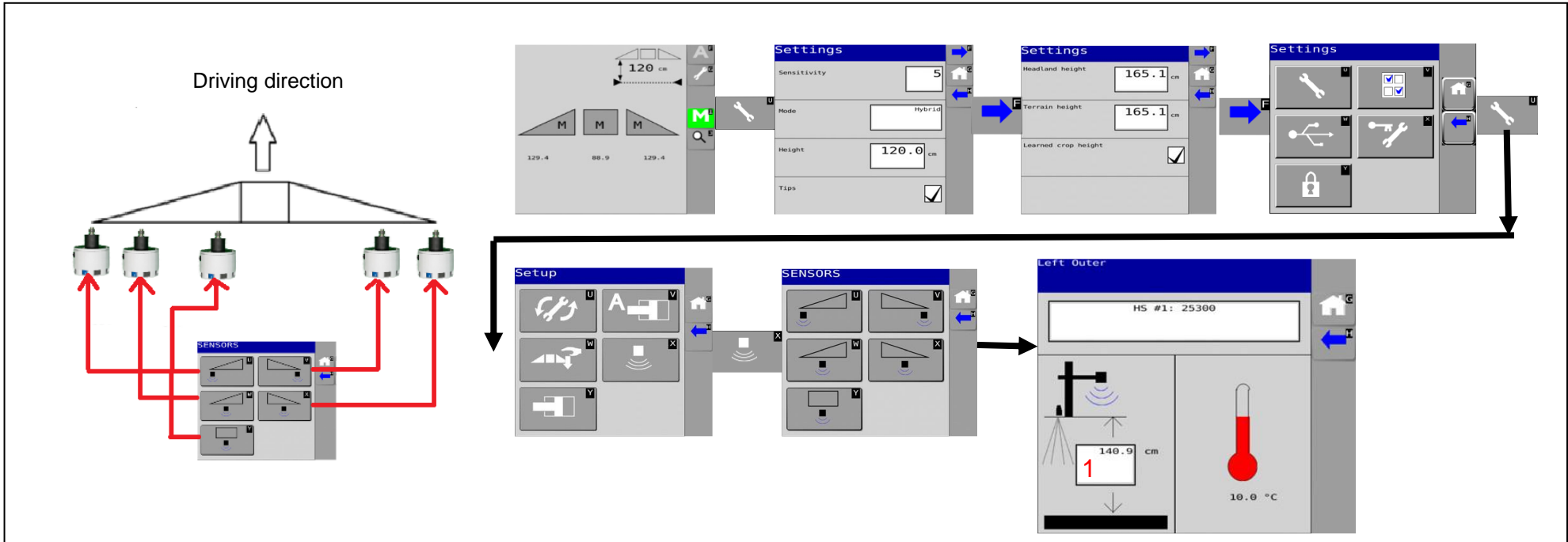

### Values of the height sensors

The values of the height sensors can be checked and changed in the height sensor menu.

Check the value of the height sensors during standing still and when the sensors are above the right surface (gravel / asphalt).

#### *Stability of values.*

During standing still the value of the sensors should not move up/down more than 5 cm.

If the value of a sensor is moving more than 5 cm when standing still, this sensor should be checked.

#### *Correct value height sensors.*

The value displayed is the distance from the soil to the bottom part of the boom profile.

If this is not correct, the value of each sensor can be changed individually (1).

## 12.3 Speed VG cylinders

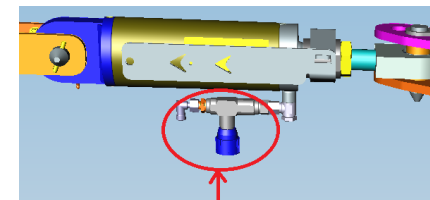
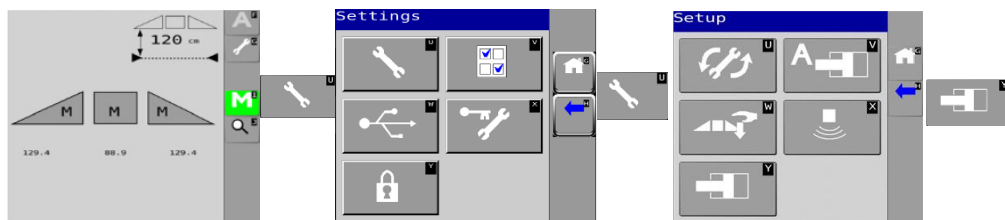

Manual restrictor on VG cylinder

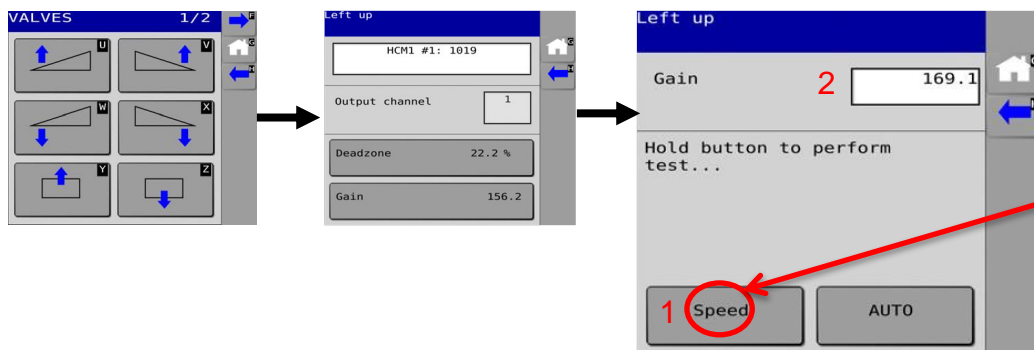

Hold "Speed" button for 4 seconds

The speed of the VG cylinders should be between 75 and 100 cm per second. This can be checked in the valves screen:

- 1) Bring the wings maximum up by operating the VG cylinders.
- 2) Navigate to the "GAIN" screen of the wing left down and wing right down.
- 3) Press the "Speed" button for 4 seconds.
- 4) Check if the value in the screen is between 75 and 100 cm.
  - If the value is bigger then 100 cm, close the manual restrictor on the VG cylinder a bit, and check again.
  - If the value is smaller then 75 cm, open the manual restrictor on the VG cylinder and test again.

## 12.4 Deadzones VG cylinders

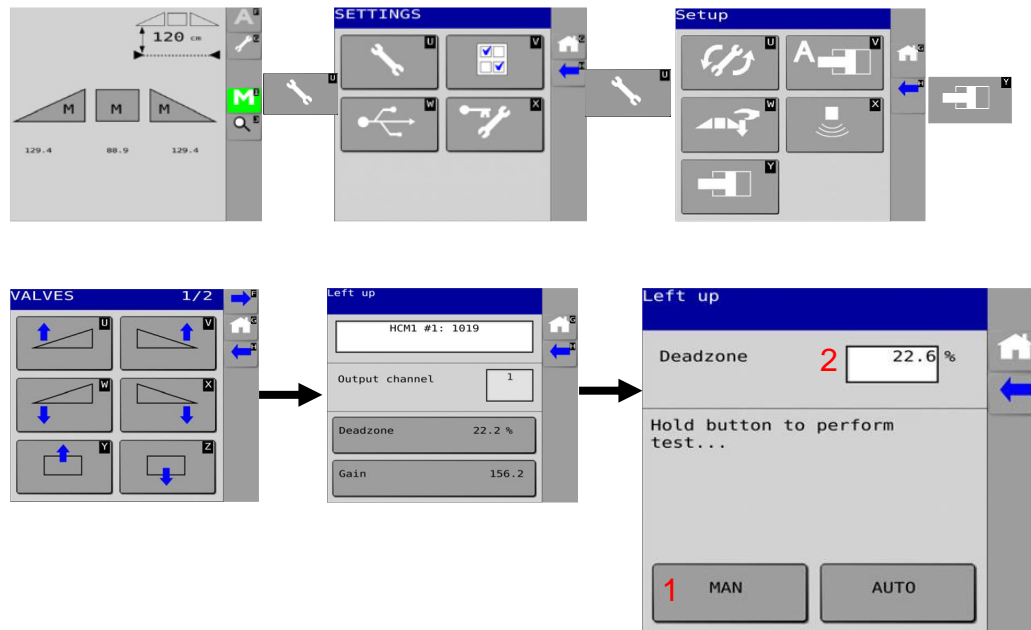

Check the deadzones for right up/down and left up/down.

By pressing “man”(1) for 3 sec, the movement of the tipend should be between 4 and 8 cm.

If the movement of the tipend of the boompark is smaller than 4 cm, the deadzone value should be increased (2) .

If the movement of the tipend of the boompark is bigger than 8 cm, the deadzone value should be decreased (2).

# 13. Trouble shooting

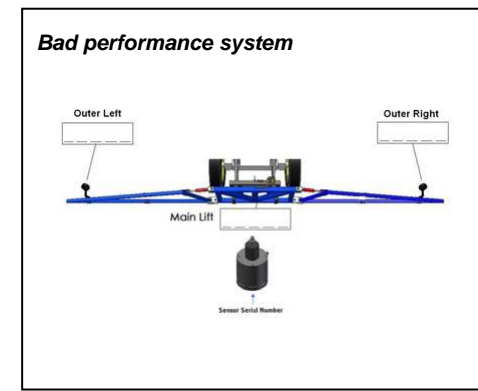
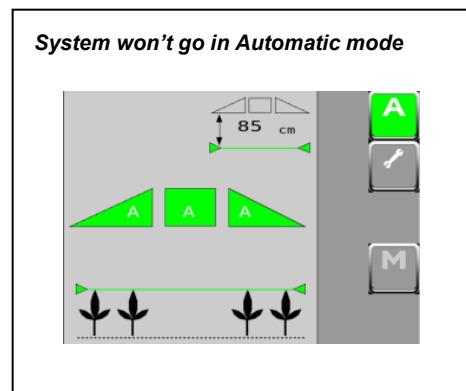
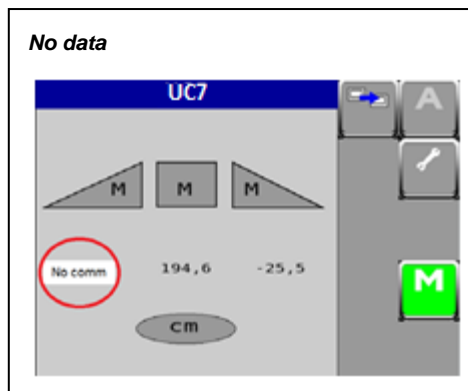
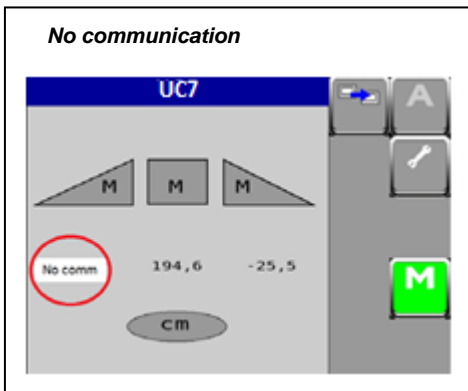

This message appears when there is no communication with one of the height or roll sensors.

Check cables on damages, check connections and possible corrosion.

Check if the CANbus terminators are mounted on the right place in the system.

Check power and ground.

Check the led status on the control module.

This message appears when the height sensor measure an invalid value.

Sensor could be out of range, too high of the target point.

Transducer in sensor is broken, no sound of faint ticking.

Foam condition, clean or replace.

Single ticking in sensor, every minute. The sensor is stuck in the program. Check Deutsch connector and restart system.

Check if the boom locking is off (switchbox).

Check the settings of shock absorbers and springs.

Check if the boom can move free and all friction pads are greased.

Check if the serial numbers of the sensors and on the boom are the same (also on the same place left/right middle).

Check oil settings of the tractor.

Make a new hydraulic retune or automatic setup.